



Clinical Director Manual

July 2023

Health Promotion Clinical Director Manual Table of Contents

ABOUT THIS MANUAL	4
CHAPTER ONE: SPECIAL OLYMPICS HEALTH & HEALTH PROMOTION OVERVIEW	5
<u>What is Special Olympics?</u>	6
<u>What is Special Olympics Health?</u>	7
<u>What is Healthy Athletes?</u>	9
<u>What is Special Olympics Health Promotion?</u>	10
CHAPTER TWO: HEALTH PROMOTION LOGISTICS & CLINICAL DIRECTOR ROLE	11
<u>Background Overview</u>	12
<u>Role BEFORE an Event</u>	12
<u>Role DURING an Event</u>	14
<u>Role AFTER an Event</u>	15
<u>Chapter 2 Appendix</u>	16
CHAPTER THREE: CLINICAL SCREENING STATIONS	36
<u>Body Mass Index (BMI) Screening Station</u>	37
<u>Background Information</u>	37
<u>Equipment and Tools</u>	37
<u>Station Layout – Body Mass Index</u>	38
<u>How to Measure – Body Mass Index</u>	38
<u>How to calculate an individual’s Body Mass Index</u>	40
<u>Body Mass Index Challenges:</u>	41
<u>Body Mass Index Quality Assurance</u>	41
<u>Body Mass Index Appendix</u>	42
<u>Waist to Height Ratio</u>	53
<u>Bone Mineral Density (BMD) Screening Station</u>	68
<u>Background Information</u>	68
<u>Equipment and Tools</u>	68
<u>Suggested Layout</u>	69
<u>How to Measure – Bone Density</u>	70
<u>Bone Mineral Density Challenges</u>	72
<u>Key Messages for athletes about protecting bone health</u>	73
<u>Bone Mineral Density Appendix</u>	74
<u>Blood Pressure (BP) Screening Station</u>	97
<u>Background Information</u>	97
<u>Equipment and Tools</u>	97
<u>Station Layout – Blood Pressure</u>	98
<u>How to Measure - Blood Pressure:</u>	98
<u>Key Messages for athletes about preventing high blood pressure</u>	100
<u>Blood Pressure Challenges</u>	101
<u>Blood Pressure Quality Assurance:</u>	102
<u>Blood Pressure Screening Appendix</u>	103
<u>Health Habits Interview</u>	110
<u>Background Information</u>	110
<u>Volunteers</u>	110
<u>Station Layout – Health Habits Interview</u>	110

<u>How to Conduct the Health Habits Interview</u>	111
<u>Health Habits Interview Appendix</u>	112
<u>CHAPTER FOUR HEALTHY ATHLETES SYSTEM (HAS)</u>	114
<u>Background Information</u>	115
<u>Completing the HAS Form</u>	115
<u>HAS Reports</u>	116
<u>How to Use HAS Reports</u>	117
<u>Chapter 4 Appendix</u>	118
<u>CHAPTER FIVE: EDUCATION STATIONS</u>	122
<u>Background Information</u>	123
<u>Equipment and Tools</u>	123
<u>Station Layout – Education Stations</u>	124
<u>Nutrition Station</u>	125
<u>Bone Health Station</u>	128
<u>Hydration Station</u>	131
<u>Sun Safety Station</u>	133
<u>Physical Activity Station</u>	136
<u>Handwashing Station</u>	139
<u>Tobacco Cessation & Avoidance Station</u>	142
<u>References</u>	144
<u>Chapter 5 Appendix</u>	145
<u>CHAPTER SIX: CHECK-OUT STATION</u>	152
<u>Background Information</u>	153
<u>Volunteer Recommendations</u>	153
<u>Station Layout – Check-Out</u>	153
<u>Equipment and Tools</u>	153
<u>Protocol - Check-Out Actions and Referrals</u>	155
<u>Check Out Challenges</u>	156
<u>Chapter 6 Appendix</u>	157
<u>CHAPTER SEVEN: VOLUNTEER MANAGEMENT</u>	166
<u>Background Information</u>	167
<u>Recruitment</u>	167
<u>Communication</u>	169
<u>Training</u>	170
<u>Supervision:</u>	171
<u>Recognition</u>	171
<u>Chapter 7 Appendix</u>	172

About this Manual

This manual is intended to introduce Special Olympics Programs, Clinical Directors, and others, to the Health Promotion program goals, protocols and strategies developed to meet the unique needs and interests of Special Olympics athletes. Special Olympics Health focuses its screening, education, referrals, follow-up and other services to help reduce health disparities for people with intellectual disabilities.

In Health Promotion, athletes engage in clinical screenings including body mass index, waist height ratio, bone mineral density, blood pressure and a health habits interview. Athletes will be exposed to health education topics including how to maintain a healthy weight, improve bone health, decrease hypertension rates, choose healthy foods to improve nutrient intake, enhance their fitness, the best ways to hydrate, avoiding tobacco exposure, and how to limit the spread of infection through proper handwashing with soap.

The manual is organized into the following seven sections:

- I. **Overview and Background:** This first section provides background information on Special Olympics and the scope and reach of our programs designed to promote athlete health.
- II. **Health Promotion Logistics:** This section covers the **Health Promotion Clinical Director's** specific roles and responsibilities before, during, and after an event. Included are the steps, equipment, materials, supplies, and other resources needed to conduct the Health Promotion core stations; and other information to help conduct a successful Health Promotion event.
- III. **Clinical Screenings and Health Habits Interview:** This section includes information on the Health Promotion core clinical screening stations, body mass index, waist height ratio, bone mineral density and blood pressure. For each, we cover why the screening is important for this population, what equipment and supplies are needed, and finally our protocols to conduct the screening. We cover the Health Habits Interview where you'll learn why the interview is important, materials used, how the interview is conducted and how it serves as a bridge between the screening and education stations.
- IV. **Health Education Stations:** This section addresses the Health Promotion education stations. In this section – the primary health education topics are discussed, including why the subject is important for Special Olympics athletes as well as the equipment, supplies and education materials needed for each station, examples of interactive experiences to develop skills and improved understanding for each education station.
- V. **Check-Out: Referrals and follow-up, athlete health goal setting:** In this section, you'll learn more about the clinical screening results thresholds where referrals are required and how referrals are made. We cover ways to help athletes determine a health goal, so athletes leave with knowledge and skills to make healthy decisions beyond the day of the screening.
- VI. **Volunteer Management:** This section includes information on the task undertaken to ensure there is enough volunteer support needed to deliver services at the Health Promotion event. Areas discussed include volunteer recruitment, screening and interviewing, orientation, training, supervision, and recognition.

The manual will be a great help as you begin your work as a Health Promotion Clinical Director so use it often and enjoy your new role in Special Olympics Health.



Special Olympics **Health Promotion**

Chapter One:
Special Olympics Health & Health Promotion Overview

What is Special Olympics?

In 1962, Eunice Kennedy Shriver started an innovative summer camp for young people with intellectual disabilities at her home in suburban Washington, D.C. The goal was to allow these young people -- most of whom lived in institutions -- to participate in sports and physical activities. This was a revolutionary idea at the time.

From a backyard summer camp for people with intellectual disabilities to a global movement, Special Olympics has been changing lives and attitudes for more than 50 years.

The mission of Special Olympics is to provide year-round sports training and athletic competition in a variety of Olympic-type sports for children and adults with intellectual disabilities, giving them continuing opportunities to develop physical fitness, demonstrate courage, experience joy and participate in a sharing of gifts, skills and friendship with their families, other Special Olympics athletes and the community. Special Olympics strives to create a better world by fostering the acceptance and inclusion of all people.

Through the power of sports, people with intellectual disabilities discover new strengths and abilities, skills and success. Special Olympic athletes find joy, confidence and fulfillment -- on the playing field and in life. They also inspire people in their communities and elsewhere to open their hearts to a wider world of human talents and potential.

Special Olympics' reach goes beyond just sports. Our programs are comprehensive and aim to improve health, build community, lead research, change attitudes, impact policy, and build leaders.

Programs such as Unified Sports, Unified Schools, and Young Athletes help to build communities that support athletes on and off the field and to ultimately improve quality of life for individuals with ID worldwide. In this training and manual, you will learn more about Special Olympics Health, and specifically, about Healthy Athletes Health Promotion.

There are about 200 million people with intellectual disabilities around the world. Special Olympics' goal is to reach out to every one of them -- and their families as well. Special Olympics does this through a wide range of [trainings, competitions, health screenings and fund-raising events](#). Special Olympics also creates opportunities for families, community members, local leaders, businesses, law enforcement, celebrities, dignitaries, and others to band together to change attitudes and support athletes.

The [Special Olympics Reach Report](#) outlines the scope and global impact of Special Olympics from sports to family leadership activities to health programs. With more than 4.9 million athletes in 172 countries in 32 sports and over a million volunteers, the scope is broad and impact significant. See the latest Reach Report (below) at <https://resources.specialolympics.org/planning-and-finance/reach-report>

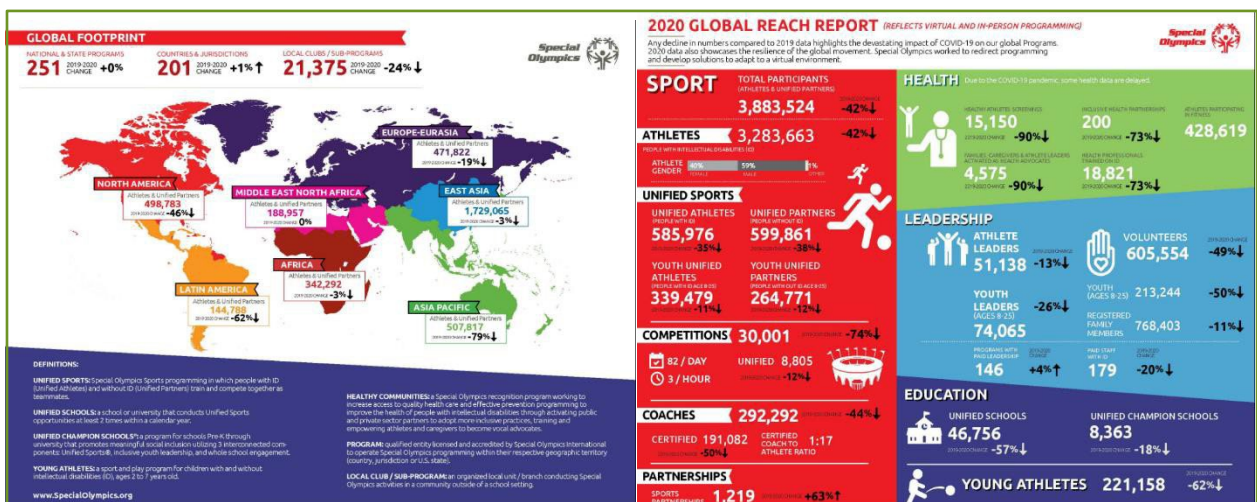

What is Special Olympics Health?

Over the years, Special Olympics got involved in health because many athletes show up to train and compete while in pain, are not able to hear their teammates, have chronic health issues that are undiagnosed, or lack fitness and conditioning knowledge putting them at risk for injury. This is why Special Olympics became interested in athletes' health.

Special Olympics started collecting data on athletes and their health and have found some astonishing statistics:

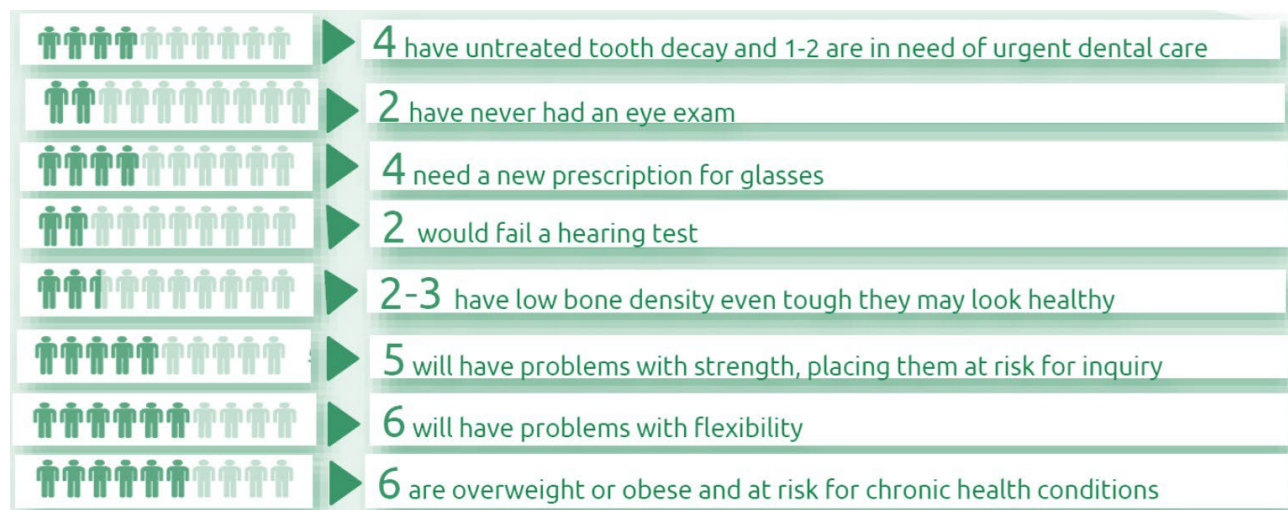

Through its sports training and competition opportunities, Special Olympics provides a health intervention for people with intellectual disabilities, bringing one of the most sedentary and at-risk populations into an organized program of physical activity. Our array of programs promotes health, wellbeing, and social inclusion.

While sport and physical activity is an important and crucial health intervention, Special Olympics Health goes further by working to create inclusive health for people with ID. Special Olympics Health aims to create inclusive health for people with ID worldwide by training health care providers, partnering to influence change, identifying and building capacity of communities to provide health services for people with ID, and collecting data to impact change.

- Special Olympics has trained more than 260,000 health care professionals and students in over 135 countries. Providers overwhelmingly report that, as a result of the knowledge and skills they gained, they are more likely to provide overall better care for their patients or clients with ID.
- Special Olympics collaborates with non-governmental organizations, ministries of health, universities, professional associations, and other stakeholders to create sustainable health services with trained health workers, policies, programs and laws fully inclusive of people with ID.
- Special Olympics is identifying and working with communities to help build their capacity to create an infrastructure and support system to better meet the needs of individuals with ID.
- The data collected is some of the only health-specific data for people with intellectual disabilities. This data is rich in information to help influence policy changes, academic and medical training, legal protection, and social justice.

Now you know why Special Olympics Health is important. Let's now learn about its programming areas.

Five Major Areas of Special Olympics Health Programming

- **Healthy Athletes:** Healthy Athletes, a Special Olympics program with over 20 years of history, provides screenings, education, and referrals to athletes in eight categories of preventive health: podiatry, physical therapy, health promotion, audiology, sports physicals, vision, emotional wellness, and dentistry. Through Healthy Athletes, health care professionals receive trainings in working with patients with ID.
- **Healthy Communities:** Model program working to ensure year-round access to quality health care and prevention programming through community-based solutions to improve the health status of people with ID.
- **Fitness:** Special Olympics encourages individuals with ID to pursue a life of fitness through physical activity, nutrition, and hydration. Programs and resources for individuals, coaches, families, and communities support healthy habits both within and outside of the sports experience. There are tools and programs that exist within Fitness.
- **Family Health Forums:** Family Health Forums, which are designed to engage families of Special Olympic athletes, offer an environment where parents and caregivers can gain direct access to health information, resources, and support.
- **Inclusive Health Systems:** The Inclusive Health Systems initiative looks through a health systems lens to work to address these disparities on a larger or macro scale. Inclusive health happens when organizations from across health systems have made the necessary adaptations to ensure that all people, regardless of their disability, are included in mainstream health policies and laws, services, training programs, research, and funding streams. The inclusive health effort works at the national level with mainstream organizations to raise awareness of the disparities and provide resources to help organizations begin to take necessary actions to ensure inclusion of people with ID in their existing services, programs, and/or funding streams.

There may be opportunities for you, as a Clinical Director, to take part in each of these five areas, and we encourage you to contact your Special Olympics Program to learn more about what they are doing in each of these areas and how you could be involved. However, since this manual is focused on your role as a Clinical Director for Healthy Athletes in Health Promotion, let us delve into a little more detail on that programming now.



To learn more about what you could do in your own practices and community, check out the Special Olympics Center for Inclusive Health: <https://inclusivehealth.specialolympics.org/>

What is Healthy Athletes?

The Special Olympics Healthy Athletes program provides free health screenings, health education and referrals in a fun and welcoming environment. The atmosphere helps remove anxiety and hesitation people with intellectual disabilities may experience when faced with a visit to a doctor or dentist. The impact of Healthy Athletes on the health and well-being of our athletes around the world is significant. In some instances, the identification of previously unknown health issues and/or providing health care otherwise unavailable has saved lives. Moreover, Healthy Athletes, in partnership with our athletes, helps to train health care professionals through the volunteer experience. These professionals return to their practices with improved knowledge of and compassion for people with intellectual disabilities. Visit the [Special Olympics Health Research website](#) for more information and health screening data



There are eight disciplines in Healthy Athletes. Information and resources are available for each on the [Special Olympics Health Resources website](#).

	<p>MedFest offers the physical screenings that all athletes need prior to participating in Special Olympics sports. In addition to collecting basic self-reported health history, screenings mirror a standard sport physical and include vitals, height and weight, as well as basic vision, cardiac, neurological, and general health assessments.</p>
	<p>Special Olympics Lions Cub International Opening Eyes provides free vision assessments, prescription eyewear, sunglasses, and sports goggles for Special Olympics athletes. With a 12-step visual exam, new prescription glasses are provided. Through our corporate sponsors, athletes can choose free eyewear and/or receive protective prescription sports goggles. Athletes who do not need any corrective lenses receive sunglasses.</p>
	<p>Healthy Hearing provides athletes free hearing screenings and other medical services, including ear wax removal, swim molds, hearing aid maintenance and minor repairs</p>
	<p>Special Smiles provides athletes comprehensive oral health care information, free dental screenings, and instructions on correct brushing and flossing techniques. Athletes are also provided with preventive supplies, such as toothpaste, toothbrushes, and fluoride varnish</p>
	<p>Health Promotion focuses on healthy living, healthy lifestyle choices, and nation-specific health issues. In addition to health education activities, it offers screenings for Body Mass Index, Waist Height Ratio, Bone Mineral Density, Blood Pressure. Health Promotion goals include encouraging and enhancing healthy behaviors and improving self-efficacy and self-advocacy.</p>
	<p>FUNFitness is a physical therapy event that addresses the ongoing health needs of Special Olympics athletes. FUNfitness provides athletes the opportunity to be screened for flexibility of hamstring, calf, shoulder rotator and hip flexor muscles; functional strength of abdominal, lower extremity and upper extremity muscles, static and dynamic balance, and aerobic fitness.</p>
	<p>Strong Minds is an interactive learning activity focused on developing adaptive coping skills for maintaining emotional wellness under stress, such as: thinking positive thoughts, releasing stress and connecting with others. Athletes learn about and try a few different active coping strategies as they move through the stations. Before exiting, athletes identify the strategies they like best, and volunteers provide them with visual reminders to use these tools in competition and in daily life.</p>
	<p>Fit Feet offers podiatric screenings to evaluate ankles, feet, lower extremity biomechanics, and proper shoe and sock gear to athletes. Foot specialists work with athletes to evaluate problems of the feet, ankles and lower extremity biomechanics.</p>

What is Special Olympics Health Promotion?

Health Promotion is the process of enabling people to **increase control over**, and to **improve**, their **health**. It moves beyond a focus on individual behavior towards a wide range of social and environmental interventions.

Special Olympics Health Promotion's goal is to improve the quality of life and long-term health of Special Olympics athletes through education on healthy behaviors, screening and medical referrals when appropriate.

Objectives of Health Promotion are to:

- Deliver screening and referral services
- Provide health education to encourage and enhance healthy behaviors
- Reduce risky behaviors
- Improve self-efficacy and self-advocacy
- Increase the investment of health promotion leaders for people with intellectual disabilities.

CORE SCREENING STATIONS	
Body Mass Index	Waist Height Ratio
Bone density	Blood pressure
	Health Habits Interview
CORE EDUCATION STATIONS	
Nutrition	Physical Activity
Bone Health	Tobacco Avoidance
Hydration	Handwashing
Sun Safety	Check-Out & Referral

We encourage clinical directors to be responsive to their community and to develop their own program beyond our core areas. Once the core health areas are offered, they are encouraged to add activities needed by their athletes. For example, programs have health topics such as cardiovascular health, night safety, sleep deprivation, diabetes prevention, food demonstrations, "Ask the doctor, nurse or nutritionist" stations, community gardening and hosting a milk mustache photo booth. Partnering with public health and community based programs can help leverage resources and volunteers to add new topic areas.

Special Olympics Health Promotion

Special Olympics Health
Golisano
CDC

Health Promotion conducts health screenings in four key areas: body mass index based on height and weight, waist-to-height ratio, blood pressure, and bone mineral density. Using interactive educational tools, demonstrations and displays trained volunteers to work with athletes to raise awareness and enhance skills to improve and maintain wellness and self-care. In this environment, athletes learn how small changes in behavior can help them improve and maintain good health and sports performance.

Purpose and Goals:

The mission of Special Olympics Health Promotion is to improve the quality of life and long-term health of Special Olympics athletes and people with intellectual disabilities (ID) through healthy behaviors, screenings, and medical referrals when appropriate.

Objectives of Health Promotion are to:

- Deliver screening services and referrals.
- Encourage and enhance healthy behaviors of athletes by eating a healthy diet, effective handwashing, tobacco avoidance, enhancing fitness, and safe sun exposure.
- Reduce risky behaviors, such as tobacco use and poor nutrition.
- Improve self-efficacy and self-advocacy.
- Increase the investment by public health agencies and officials, as well as private health care providers in service to people with intellectual disabilities and developmental disabilities.

Importance and Impact

At Health Promotion events we learned that a large percentage of Special Olympics athletes have limited knowledge of proper health practices and many suffer from potentially serious health issues. Below is a snapshot of our data from Healthy Athlete Screenings in the U.S. in 2018:

- 76% of Special Olympics adult athletes are overweight or obese.
- 50% of Special Olympics youth (less than 20 years of age) athletes are overweight or obese.
- 26% of Special Olympics adult athletes have low bone density and increased risk for bone fracture

Contact:
healthpromotion@specialolympics.org

US Version. Last updated in February 2022.



Health Promotion event in New Delhi, India 2018

This one-page, [Health Promotion Fact Sheet](#) includes program highlights and accomplishments.



Special Olympics **Health Promotion**

**Chapter Two:
Health Promotion Logistics & Clinical Director Role**

Background Overview



Clinical Directors are the essential member of the Healthy Athletes Health Promotion team. Clinical Directors are responsible for working with their local Special Olympics Program and other volunteer health professionals to coordinate Health Promotion events in their region.

The [Role of the Clinical Director](#) is exciting and rewarding and involves activities before, during and after the events. We will discuss the Clinical Director’s roles throughout the manual, but Chapter 2 provides:

- an overview of duties **before**, **during** and **after** a Health Promotion event and
- resources and tools to help you deliver a quality Health Promotion event. Remember, each Program manages things a little differently so it will be important to coordinate with your local Special Olympics staff.

Role BEFORE an Event

1. Schedule a meeting with your local Special Olympics Healthy Athletes (HA) coordinator

Identifying and scheduling the best opportunities to offer a Health Promotion event should be a joint effort between the Clinical Director and their local Special Olympics Program. Clinical Directors will determine which screening and education stations to offer and how, based on local needs and available resources.



Explore the “[Questions to ask your Healthy Athletes coordinator](#)” document in the appendix for guidance on the topics and questions for discussion during this meeting.

2. Recruit and train volunteer health professionals

Clinical Directors identify and train health volunteers to work in the specific areas to be offered at Health Promotion, because they know their community and its local health care professionals. [See Volunteer Management Chapter 7](#) for more information.

Volunteers might include:	Potential volunteers may come from:
<ul style="list-style-type: none">• Physicians, nurses, dietitians, kinesiologists, and other allied health professionals.• Medical and allied health professional students• Public health educators and students• General public for select stations	<ul style="list-style-type: none">• Private practitioners• Universities, colleges, and schools• Health and professional associations• Medical facilities• Government medical facilities: Military/VA/state/national/local public health agencies



Check out the [HP Recruitment templates](#) and [promotional video](#) and [training video](#) available on the [Special Olympics Health Promotion Resources Page](#) to help recruit and train volunteers. (<https://resources.specialolympics.org/health/health-promotion>)

3. Contribute to preparation of the Capacity Grant application

Special Olympics Programs can apply for a grant from Special Olympics International to help offset costs of hosting a Healthy Athlete event. These grants allow Programs to purchase interactive educational materials and tools, athlete giveaways and educational incentives, volunteer recognition items, signage, printed materials and supplies and equipment needed to conduct an impactful Health Promotion program. Clinical Directors should work with their local Program to assure that supplies and equipment needed to deliver the core components of HP are included in the Healthy Athletes' Capacity Grant application. After the event, the Clinical Director may be requested to assist with post-event reporting, if the Program received a Capacity grant.

Additional grants through Special Olympics International may be available to Programs for ongoing wellness and fitness programming. The Program may also request your assistance to apply for local grants, donations and sponsorships, depending on your interest and availability. These are outside the scope of a Clinical Director, but excellent opportunities.



Review the “[Sub-Award Grant Evaluation Report Template](#)” document in the appendix to see a sample of the report on which you may be requested to assist regarding HP metrics.

4. Obtain equipment, supplies and athlete educational incentives

Needed supplies, equipment and athlete giveaways may be available to Clinical Directors through donations or loans obtained from local sponsors and health service providers. Clinical Directors should work with the local Special Olympics Program staff to determine what equipment and supplies are currently available, what is needed and how to obtain those items needed e.g., donation, purchase, loan.

NOTE: Special Olympics headquarters also will sometimes have supplies available, upon request.

Item/Supply Item	Refer to HP CD Manual for ordering and additional requisitions	Comments/Notes/Recommendations	Quantity/Notes/Training Method	Vendor/Website	Estimated Cost
Banners - Health Promotion	Refer to HP CD Manual for ordering and additional requisitions	For use in all health promotion events. Banner for each program. Banner for each program. Banner for each program. Banner for each program.	2 per banner. One banner for each program. Banner for each program. Banner for each program.	For use in all health promotion events. Banner for each program. Banner for each program. Banner for each program. Banner for each program.	Always use the HP banner. Banner for each program. Banner for each program. Banner for each program. Banner for each program.
Health Education Station Posters	Refer to HP CD Manual for ordering and additional requisitions	The poster is a guide for athletes to use with athletes. The poster is a guide for athletes to use with athletes. The poster is a guide for athletes to use with athletes. The poster is a guide for athletes to use with athletes.	1 per education station.	SO Health Promotion Resources website. Health promotion website. Health promotion website. Health promotion website.	None.
Clipboard - Change Cards	Refer to HP CD Manual for ordering and additional requisitions	For use in all health promotion events. For use in all health promotion events. For use in all health promotion events. For use in all health promotion events.	1 per education station.	SO Health Promotion Resources website. Health promotion website. Health promotion website. Health promotion website.	None.
Athlete Health Report	Refer to HP CD Manual for ordering and additional requisitions	For use in all health promotion events. For use in all health promotion events. For use in all health promotion events. For use in all health promotion events.	1 per education station.	SO Health Promotion Resources website. Health promotion website. Health promotion website. Health promotion website.	None.
Plastic baskets	Refer to HP CD Manual for ordering and additional requisitions	For use in all health promotion events. For use in all health promotion events. For use in all health promotion events. For use in all health promotion events.	1 per education station.	SO Health Promotion Resources website. Health promotion website. Health promotion website. Health promotion website.	None.



Familiarize yourself with the recommended [Health Promotion Equipment and Supplies List](#) available in the appendix on the Special Olympics Health Promotion Resources Page (<https://resources.specialolympics.org/health/health-promotion>)

5. Visit the Healthy Athletes venue and plan the Health Promotion venue layout

If possible, prior to the event, tour the venue facility to determine details like space, Wi-Fi access, room lighting, number of outlets, wall space for educational posters, and most importantly how you will lay out your venue to optimize athlete flow, safety, and engagement with the athletes. If a visit isn't possible, try to get photos and dimensions to aid in planning.

Factors that may impact your layout include space, days and hours of the event, anticipated number of athletes and volunteers.

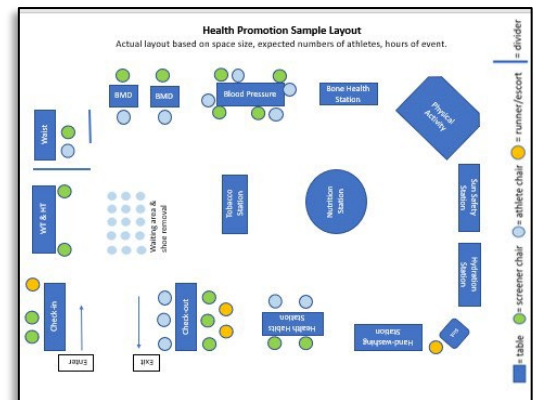

See a [sample layout](#) available in Chapter 2 appendix or on the Special Olympics Health Promotion Resources Page (<https://resources.specialolympics.org/health/health-promotion>).

Role DURING an Event

1. Set up and conduct training for volunteers

- a. On the day of the event, or sometimes on the day before, the Clinical Director should supervise the set-up of the venue.
- b. The Clinical Director should ensure that each piece of screening equipment to be used is calibrated and a quality check completed, either by themselves or a trusted volunteer.
- c. The Clinical Director should have volunteers check off a sign-in sheet for tracking purposes as well as the [Hold Harmless Agreement](#) for Programs in the US and return this to your local Program coordinator.
- d. Lastly, the Clinical Director should provide a general volunteer training prior to the event, and more specific training of volunteers on the stations at which they will be working. Ensure volunteers are comfortable and competent using the equipment, delivering the educational key messages.

BEST PRACTICE:
We suggest that volunteers arrive ~1 hour prior to the start of the event, to be trained.

[Chapter 7](#) provides checklists for training volunteers prior to the event.

2. Supervise and ensure volunteer adherence to protocols and quality

Throughout the event, it is important that the Clinical Director observe the volunteers as they deliver screening, education, and check-out to confirm that proper protocols are being followed and that referrals are being made according to the standards.



Use the “HP Venue Setup-“[Quality Assurance Check-list](#)” to guide you on the elements of a quality Health Promotion Event. (see [Chapter 2 Appendix](#))

BEST PRACTICE:
Spot check HAS forms to confirm referrals are being properly marked and provide additional training, if needed.

3. Collect and report data

Clinical Directors use Healthy Athletes System (HAS) to document screening data collected during the event. Data is used to assess the health status and needs of individual Special Olympics athletes, and to determine need for health care provider referrals. Summary reports of data collected by event, locale, date (or range of dates) is available to Clinical Directors, researchers and Program staff upon request. Contact your local Health Manager to request the report (s).

This data provides Healthy Athletes programs and health entities worldwide with information, to increase awareness, provide preventive and therapeutic health services for people with ID. The Clinical Directors have a critical role to ensure that the data is properly collected and reported.

Programs can include data entry costs in their Capacity Grants (discussed above) to assist with the data entry if tablets aren't used. More details about the HAS system is provided in [Chapter 4](#).

See [Chapter 4](#) for more information about the Healthy Athlete System and data collection.

Role AFTER an Event

1. Supervise the clean-up and pack-out

The Clinical Director should ensure that all clinical equipment and supplies are in working order, properly calibrated (if needed), packed, and inventoried before being loaded for storage or return. If equipment needs to be replaced or repaired, let the HA Coordinator know. Remove and store batteries to prevent corrosion. We recommend that you schedule volunteers to assist with this at the end of the event. Store supplies in clear plastic containers with lids. Try to keep all materials and supplies in containers by station for ease of set up at next event.

BEST PRACTICE:

Complete an inventory list at the start & end of an event to track supplies/equipment need to be re-ordered or returned or fixed.

2. Program evaluation and reporting

- a. The evaluation process gives Clinical Directors the opportunity to continuously improve and adapt their programs as needed. Screening data collected at the Health Promotion event is entered into the Healthy Athlete System (HAS). This data is summarized and available to Programs and Clinical Directors by request and through a System dashboard. See [Chapter 4](#) for more information about HAS. Use this data to assist with ongoing partnership and sponsorship development, to improve the education stations (e.g., increase focus on particularly high-risk health issues), and to improve the quality of the screenings and referrals.

The Clinical Director may be asked to share metrics on volunteer numbers, athlete numbers, donations and partnerships for Health Promotion as a part of the post-event report for the HA Capacity Grant. Be sure you have a sign-in sheet or some document where you can easily track numbers of athletes attending HP venue and volunteer numbers.

3. Thank volunteers, partners, and colleagues

Healthy Athlete events cannot run without volunteers, so think of ways to ensure interested volunteers return to help at subsequent events. Take a moment to thank your volunteers at the start, during, and at the end of the event. Take photos and email to your volunteers! Programs provide volunteer T-shirts to volunteers. Consider providing written thank-you notes and a simple volunteer certificate at the close of the event.

See [Chapter 7, Volunteer Management](#), for additional information and resources.

BEST PRACTICE:

Send your volunteers an email and volunteer certificate after thanking them for their time. Share some data about your event (e.g., # of athletes screened, # of referrals.)

CHAPTER 2

APPENDIX

1. Role of the Health Promotion Clinical Director
2. Questions to ask your Special Olympics Program Health Coordinator
3. Health Promotion section from the Special Olympics Sub-Award Grant Evaluation Report
4. Health Promotion equipment and supply list
5. Health Promotion sample venue layout
6. Health Promotion Venue Quality Assurance Checklist

Special Olympics

Health Promotion



The Healthy Athlete Clinical Director Role: Health Promotion

Special Olympics is a global movement of people creating a new world of inclusion and community, where every single person is accepted and welcomed, regardless of ability or disability. We are helping to make the world a better, healthier, and more joyful place – one athlete, one volunteer, one family member at a time.

The Healthy Athletes program provides health services and education to Special Olympics athletes and changes the way health systems interact with people with intellectual disabilities. Through free health screenings, training for healthcare professionals, and evaluation of the health status of people with intellectual disabilities, Healthy Athletes has become a powerful public health organization worldwide.

Clinical Directors are an important part of the Healthy Athletes Health Promotion Team. Clinical Directors are responsible for working with their local Special Olympics Program and other volunteer health professionals in coordinating a Health Promotion event in their region.

The role of a Health Promotion Clinical Director includes, but is not limited to:

1. *Determining event opportunities*

Identifying and scheduling the best opportunity to provide Health Promotion screenings is a joint effort between the Clinical Director and their local Special Olympics Program. Clinical Directors will also determine which areas of Health Promotion (nutrition, hydration, bone health, sun safety, tobacco avoidance, physical activity) to offer and how, based on the local needs and resources available.

2. *Recruiting and Training Volunteer Health Professionals*

Clinical Directors are the best people to identify and train health volunteers to work in the specific areas that will be offered in the Health Promotion venue, because they know their community and its local health care professionals. Potential volunteers may come from:

- Private Practitioners
- Universities/Colleges/Schools
- Health and Professional Associations
- Medical Facilities
- Government Medical Facilities (Military/VA/State/National/Local) and
- State or Local Public Health Agencies

3. Capacity Grant Application

Clinical Directors will work with their local Program to ensure that supplies and equipment needed to deliver the core components of HP are included in the Healthy Athletes' Capacity Grant application. These grants assist Programs in purchasing interactive educational materials, athlete giveaways and incentives, volunteer recognition, signage and other supplies/equipment needed to conduct an impactful Health Promotion program.

4. Obtaining Equipment, Supplies and Athlete Giveaways

Needed supplies, equipment and athlete giveaways may be available to Clinical Directors through donations or loans obtained by networking with local sponsors and health services. Special Olympics headquarters also receive donations of goods and equipment that can be made available for events if local sources are not available.

5. Setting Up and Supervising the Healthy Athletes Venue

On the day of the event, the Clinical Director is responsible for supervising the set up and delivery of screening and interactive education services by trained volunteers.

6. Collecting and Reporting Data

Clinical Directors use Healthy Athletes Software (HAS) to document screening data collected during the event. Data is used to determine the need for health care provider referrals, and to assess the health status and needs of individual Special Olympics athletes. This data provides Healthy Athletes Programs worldwide with the statistics needed to increase awareness and provide more services.

7. Program Evaluation

Evaluation gives Clinical Directors the opportunity to continuously improve and adapt their programs to the needs of the athletes.

Health Promotion Clinical Director Background and Requirements:

- A current credential or license to practice in a healthcare field which utilizes routine medical procedures. Examples include RD, RN, BSN, DTR, CHES, PA, MD, DO, PT, OT, EMT, kinesiology, chiropractor and/or a teaching certificate in a healthcare field.
- Three plus years of supervised hands-on clinical work experience in the health promotion field and/or their health care profession. Must include direct or group patient education, screening, care plan development. Experience may include up to 1 year in a supervised educational practicum.
- A minimum three-year commitment to ensure quality and continuity of the Health Promotion program.
- Attendance at a SOI sponsored Train-the-Trainer session or completion of the online Clinical Director Training Program where information and training about Special Olympics, Healthy Athletes, and Health Promotion specific management.

CHAPTER 2 - APPENDIX 2: Questions to Ask Your Local Health Coordinator Prior to an Event

After you complete the required Train-the-Trainer (TTT) program, the Program will be notified that you have completed the training. It is important to re-introduce yourself after the TTT and if possible, arrange to meet your Program's Health Coordinator in person or by phone.

Review your Program's website and familiarize yourself with their activities, scope and initiatives prior to your meeting. Share an overview of HP-CD TTT program with coordinator when you meet.

General questions to ask *Some programs provide in a Program Profile sheet with pertinent information.*

- Which disciplines are offered through your HA program? Is it customary or possible to arrange a meeting or call with the other clinical directors, to discuss cross-disciplinary planning prior to the event?
- Ask to see a copy of the [Athlete Consent](#) to participate in HA and to appear in event photos.
- Ask to see a copy of the Clinical volunteer "[Hold Harmless](#)" forms
- How is communication between your Program manager handled: by email, phone, in person or at in-person meetings?
- What process is followed to refer athletes to follow-up care? How is referral follow-up tracked after an event?
- Will the program apply for an SOI Capacity Grant? How can you help with the equipment & supplies request?
- When planning for a specific event:
 - How many athletes are expected to attend? What age range?
 - Clarify the space and venue for the event and draft a layout.
 - Discuss electricity needs, the possibility of running water for handwashing education and the space needed for the stations you plan to offer.
 - Consider athlete flow, wait areas, planned stations, check-in & check-out when drafting venue layout.
 - How is your travel arranged for out-of-town Healthy Athlete events?

Equipment and supplies issues - Share a copy of [HP Equipment and Supplies List](#) with your Program.

General

- Using the list, ask what equipment and supplies your program has in stock. Where are items kept?
- What needs to be borrowed, requested from SOI, or purchased before the event? Who makes those requests – the coordinator or you?
- How are these items delivered to the Healthy Athletes event location?
- How will necessary documents be printed? Who is responsible?

Donations or borrowing equipment

- What's the process for requesting donations?
- Who sends thank you letters for donations?

Consider screening equipment that may be available locally or from SOI

- Body Mass Index stadiometers, scales from public health departments, clinics or university or colleges
- Bone Mineral Density: Sahara, GE Achilles, Osteosys or other approved equipment from SOI, medical equipment distributors, medical clinics, pharmacies, fitness gyms, university or colleges
- Blood pressure monitors: public health departments, clinics, Red Cross, universities or colleges

Consider Education Station Incentives or educational reminders that might be available locally or through donation

- **Nutrition:** Fresh or dried fruits and vegetables or other healthy snacks. For more information on healthy snacking guidelines review the [Healthy Food and Beverage Toolkit](#)
- **Bone Health:** String cheese, unsweetened fat-free (light) yogurt, small cartons of Fairlife or other brands of skim or low-fat milk
- **Hydration:** Water dispensers and paper cups, or bottled water
- **Sun Safety:** Sunscreen, SPF lip balm, and Solar Bracelets (check with SOI), hats with brims, UV protective sunglasses (not for world or national games due to sponsorship issues)
- **Physical Activity:** stretch bands, dance CD's, frisbees, jump-ropes, weighted hula-hoops
- **Tobacco avoidance:** Build on your local health department campaign, avoidance and quit materials
- **Handwashing:** small bars of soap, buckets, wash clothes and hand towels (avoid hand sanitizers as these don't remove dirt, are costly and not appropriate for use in teaching handwashing. Some programs may wish to expand this station to addressing overall hygiene topics.

Resources for athlete educational incentives and thank-you gifts: Discount stores, dollar stores, online suppliers like Amazon, Alibaba, Walmart or local grocery stores.

Questions regarding volunteers

Recruit Volunteers

- Where will you recruit volunteers from? How many do you need, based on days and hours of HA event?
- Does the Program have existing recruitment materials and partner organizations? How can you use your professional network to determine who can help you recruit?
- Does the Program maintain a list of previous Health Promotion volunteers?
- How do volunteers register?
- Can athletes be incorporated into the Health Promotion event as peer educators or in other ways?

Train volunteers (additional details on volunteer training included in Chapter 7)

- Are volunteers trained in advance of the event or day of the event? If you will have training on the day of the event, where will it be provided?
- What types of volunteers do you have available, for example, clinical, general, experienced volunteers, students? Will you have the volunteers with the type of expertise you need?
- What should the volunteers wear? Will they be given a volunteer t-shirt? If a volunteer leaves, and another arrives, who teaches the new person?

Schedule & supervise volunteers

- Are there written expectations for scheduling and overseeing volunteers from the Program?

Considerations before, during and after the HP event: The Clinical Directors role is to manage volunteers and the overall venue rather than to staff individual stations. You will be needed to trouble-shoot, answer questions and solve issues as they arise to ensure the full event is running smoothly.

Before and During Event:

- What time is the venue set-up scheduled? Are there general volunteers scheduled to assist with set-up?
- How will you obtain the names and cell phone numbers of "who to call if..." e.g., medical operations for high BP, security issues, lunch issues, etc.?
- What is the plan to keep the venue neat and tidy? If it is a multi-day event, where are supplies and equipment stored overnight?

- Where will emergency medical services be located?
- Who will take and share photos of each station, athletes in the venue and athlete souvenir photos? Ask about local Program policy about gaining permission to use athlete images.
- Complete the [HP Venue Quality Assurance Checklist](#) and share with HA Coordinator and fellow Health Promotion clinical directors after the event?

After Event:

- How are completed HAS Forms passed along to the Program for referral follow-up and data entry?
- Does the Program have an overall plan for volunteer appreciation? Certificates or small token of appreciation?
- What is the preferred process to inventory remaining supplies, and how will items be stored?
 - Create list of items needed for the next event including clinic supplies, educational materials, athlete incentives, forms. Identify broken or damaged equipment or depleted supplies; store supplies by station in labeled clear plastic bins; remove batteries and re-package equipment
- Who is responsible for returning borrowed equipment (e.g., bone density machine, scales and stadiometers, blood pressure equipment), if applicable? Note: repack carefully, according to instructions. Local programs are responsible for repairs in the event of incorrectly packing borrowed equipment.
- How will Clinical Directors debrief?
 - Use the HP Venue Quality Assurance checklist to debrief interested Program staff, volunteers, and others, during a discipline specific de-briefing call after the event.
 - Create notes about what went well. Where can you improve your volunteer training, station activities, athlete flow, participation rates, etc.? What would you like to change at your next event? Request feedback from Healthy Athletes Coordinator on how s/he feels the event went.
- How are photos and human-interest stories about your athletes (including names and contact information) shared with local Program staff and the [Manager for Health Promotion at SOI](#)?

CHAPTER 2 - APPENDIX 4: Health Promotion Section from the Special Olympics Sub-Award Grant Evaluation Report

You will need to capture this information to share with your Special Olympics Program for their evaluation and financial report to Special Olympics Inc., if they received a Capacity Grant:

Health Promotion Clinical Director

First time you've held this discipline for your Program?	Yes <input type="checkbox"/> No <input type="checkbox"/>	First time you've held this discipline in this location?	Yes <input type="checkbox"/> No <input type="checkbox"/>
Number of athletes screened ages 8+		Number of Young Athletes screened < age 8:	
Number of referrals made:			
Volunteers (enter numbers below)			
Dietitian/Nutritionist		Other health professional, specify:	
Physician		Students-public health, nutrition, nursing, etc.	
Nurse		Students-general	
Public Health Educator		Non-Clinical volunteers	

Did you have enough volunteers? Yes No If no, please explain:

Did you have enough equipment and supplies? Yes No If no, please explain:

After this Healthy Athletes event, what did/will you do to help connect athletes with follow-up care? (check all that apply for each Healthy Athletes discipline)







	Contact caregivers about screening results			Recommend specific doctors or provide list of possible doctors	Have formal or informal community partnerships to provide free or reduced cost follow-up services (if yes, please provide the name(s) of your partner(s))	Other (please specify)
	in person	by phone	by e-mail			
Health Promotion	<input type="checkbox"/>	<input type="checkbox"/>	<input type="checkbox"/>	<input type="checkbox"/>	<input type="checkbox"/>	<input type="checkbox"/>

Evaluation Report Questions related to Health Promotion as of April 2021

CHAPTER 2 - APPENDIX 5: Health Promotion Equipment and Supplies List 2022







Use this list to determine your equipment and supplies costs for your event. Unused, non-disposable items should be collected at the end of the event and stored under lock and key to support future events. When filling this information out for future events, conduct an inventory to determine what items you will or will need to obtain for your next event. Contact [Health Promotion Manager for additional guidance](#).



Health Promotion Equipment and Supplies List 2022

Standard Supply	Example Picture	Recommendations/ Comments	Quantity Advised Per Manual	Available From	Estimated Cost
Printed Materials					
Choose-to- Change Cards		To have athletes select 1-2 cards at Check-out. Available in multiple languages Print in color on cardstock	Based on number of athletes expected	SOI Health Promotion Resources website Print Locally	varies
Athlete Health Report (screening results)		Volunteer transfers screening data to form so athletes can take to share with parents, caregiver, MD. Print in color	1 per athlete	SOI Health Promotion Resources website <ul style="list-style-type: none"> Athlete Health Report (PDF) 	varies
Athlete Health Report Screeners Tool		This is a resource to guide the volunteer in completing the Health Report and providing proper referrals. Print in color	1 per check-out station volunteer	SOI Health Promotion Resources website Screener Reference Tool Print Locally	varies
Screening Referral Guides (4 Total)		Print each in color, double-sided and then put in plastic sleeves and into binder or folder for each volunteer at Check-out & relevant screening station. Print in color	1 per station and check-out volunteer	SOI Health Promotion Resources website WHtR , BP , BMI Adult , BMD Print Locally	varies
HAS Form (if not using tablets)		HAS Form is used to record athlete screening data.	1 per athlete	SOI Health Promotion Resources website HAS 2022 Print Locally	varies
SOI Education Station Posters (7 total)		Horizontal and vertical versions of the posters. They serve as a guide for volunteers on key messages to cover with athletes.	1 per education station	SOI Health Promotion Resources website <ul style="list-style-type: none"> USA with CDC logo (PDF) Non-USA (PDF) 	varies
Health Habits Photo Guide		This template can be customized for your local region/country to guide the Health Habits interview.	1 per health habits station	SOI Health Promotion Resources website Health Habits Interview Photo Guide (DOCX • PDF) Print Locally	varies

Screening Station Supplies

Select Supplies available for US programs through Henry Schein partnership. Contact [Health Promotion Manager](#)











Stadiometer		<p>Portable adult/infant measuring unit; approximately \$195 for plastic stadiometer or \$400 for wooden.</p> <p>Do not use a stadiometer attached to a scale</p>	<p>1 or more (Grant funds can be used for 1 stadiometer), Henry Schein donates for SONA</p>	<p>Seca 213 from Amazon SOI has a limited number for US Programs. Contact Health Promotion Manager</p>	\$200 US
Digital scale		<p>Recommend: Tanita WB-800AS digital-- approximately US\$425 or SECA 869, approximately US\$375.</p> <p>Select scale that weighs up to a minimum of 400lbs & can be calibrated. Not on wheels.</p>	<p>1 or more (Grant funds can be used for 1 scale.) Henry Schein donates for SONA</p>	<p>Seca 869 from Seca Tanita WB 800-AS from Tanita SOI has a limited number for US Programs. Contact Health Promotion Manager</p>	~\$400.00
Body Mass Index Wheels adult (or use BMI phone app, if WIFI is available)		<p>Use to determine athlete BMI for athletes 20 years of age and older</p>	<p>1 for each BMI station and for each check-out station.</p>	<p>For US-Canada Programs: contact Health Promotion Manager For International Programs: order online Or use an online tool/app</p>	\$5.00
Body Mass Index Wheels pediatric (or use BMI phone app, if Wi-Fi is available)		<p>Use EZ Plot Pediatric BMI Wheel to determine BMI for athletes up to age 20.</p>	<p>1 for each BMI station and for each check-out station.</p>	<p>For US-Canada Programs: contact Health Promotion Manager For International Programs: order online or use a phone app.</p>	US \$5.00
Tape Measure Imperial or Metric specs: flexible vinyl or cloth, 0-183cm/0-73inches		<p>To measure athlete waist circumference- recommend tailor's tape measure.</p>	<p>5 or more <i>Grant funds can be used for up to 10 tape measures</i></p>	<p>Amazon.com 4 pack flexible tape measure \$3.99 plus shipping (free with Prime) SOI has a limited number for US Programs. Contact Health Promotion Manager</p>	\$5 to \$20 (US)
Blood pressure kits and cuffs Note: have batteries		<p>Be sure to have all the proper cuff sizes: Adult, extra-large & pediatric cuffs. Omron is one of several good brands. Also suggest having at least one manual BP cuff and kit.</p>	<p>Varies depending on # of athletes, at least: 3 adults; 1 XL; 1 pediatric and 1 pediatric</p>	<p>varied medical equipment suppliers or see if you can get donated Contact Health Promotion Manager Henry Schein donates for SONA</p>	varies
Bone density machine		<p>Three Bone Density Machines have been approved by SOI:</p> <ol style="list-style-type: none"> 1. Hologic Sahara 2. GE Achilles Express 3. OsteoSys 3000 <p>See manual for more information. Contact Health Promotion Manager w/ questions</p>	<p>1 or more</p>	<p>Try to borrow a machine from a local clinic or hospital. Machines are available for loan in US Complete the request form on the SOI Health Promotion Resources webpage GE Achilles Request Form</p>	\$7000 purchase or ~\$500return shipping if borrowed

Bone density clinic supplies GE ACHILLES		GE Achilles Supplies 1. A gallon of distilled water 2. 70% Isopropyl alcohol 10 oz/60 tests 3. Paper towels (1 per machine/60 tests) 4. Spray bottle (for alcohol) 1 per machine	See below	Can be purchased at a “Dollar Store” or Wal-Mart/Target	
Bone density clinic supplies OSTEOSYS	To be added	To be added	To be added	To be added	To be added
Bone density clinic supplies SAHARA		The Sahara Machine needs 1. Transducer Gel/Alcohol 2. Foot sheets 3. Cleansing wipes 4. Transducer pads	See below	Order from the company of the machine you are using.	estimate .50 per person tested. Transducer pads \$125.00

Sahara Supplies and Recommended Quantities Programs will need to purchase disposable supplies to perform BMD tests for athletes on the Sahara and Achilles. .			
Item	Purpose	Estimated need	Availability
Foot sheets	Infection control	1 sheet per athlete	Through SOI or buy from Hologic – US \$0.10 each (500 per box)
Coupling gel	Transmits sound waves	1 tube per 50 tests (2 heels)	Through SOI or buy from Hologic - US \$6 per tube
Printer tape (thermal)	Print QC results	1 roll per 100 tests	Through Hologic or office supply store – US \$1-4 per roll
Kim wipes	Clean transducers	1 box per machine	Through Amazon – US \$2 per box from Amazon
Baby Fresh Wipes	Clean outside of machine	1 small box per event	Buy locally
Kleenex	Wipe heels	1 per machine	Buy locally
Surge Protector & extension cord	Protect in power outage	1	Buy locally
Achilles EXPII supplies and recommended quantities			
70 % isopropyl alcohol	Transmits sound waves, disinfect	2 per day	Buy locally
Distilled water	Activates membranes	1 per day	Buy locally
Paper towels	Clean machine and below footbed	1 per day	Buy locally
Kleenex	Wipe heels	2 per machine	Buy locally
Microfiber cloth	Clean touch screen	Reusable	Buy locally
Surge Protector & extension cord	Protect in power outage	Reusable	Buy locally
Funnel	To simplify adding water to device	Reusable	Buy locally

Education Station Supplies

*These are examples as what you may need. [Additional suggestions are found in the Education Station/lessons plans.](#)
Specifics depend on the planned education activities. For additional information on equipment and supplies contact the [Health Promotion Manager](#)*







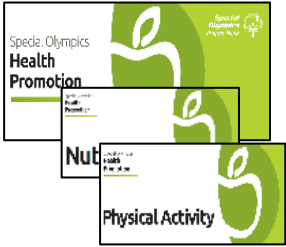

<p>Small Posters/ displays</p>		<p>Nutrition education, Food pyramid, health promotion posters and materials, include hand washing, food safety, smoking cessation</p>	<p>depends on number of stations</p>	<p>Explore USDA-my plate, CDC- nutrition & physical activity web sites or check with your local health departments or ministries of health Additional posters available at: SOI - Health Promotion Resources website</p>	<p>many free downloads</p>
<p>SOI Education Station Posters</p>		<p>Horizontal and vertical versions of the posters. They serve as a guide for volunteers on key messages to cover with athletes.</p>	<p>1 per education station</p>	<p>Print Locally US Programs can request from Health Promotion Manager See SOI Health Promotion Resources</p>	<p>varies</p>
<p>Food Models – Plastic or real</p>		<p>Use for interactive nutrition education. Use fake food, fresh food or food pictures as a substitute.</p>	<p>Include items from all food groups: dairy, grains, f & v, meats, legumes, fats</p>	<p>http://www.enasco.com/product/WA29168HR or https://www.healthedco.com/79716-Faux-Foods-Deluxe-Starter-Package-57 check Amazon "food replicas"</p>	<p>\$395 (includes 42 food items)</p>
<p>Interactive game or spinning wheel</p>		<p>Use for interactive education in several areas, handwashing, physical activity, nutrition</p>	<p>1 or more</p>	<p>For example Amazon.</p>	<p>\$69-\$100, varies</p>
<p>Inflatable cows (or something to attract attention)</p>		<p>Use to promote dairy products and to decorate the venue. These are reusable. Inflate with a hand pump.</p>	<p>1</p>	<p>Amazon – Cow Balloon Amazon – Inflatable Cow Amazon – Small Inflatable Cows</p>	<p>Varies</p>
<p>Foam Skeleton Floor Puzzle</p>		<p>Interactive teaching tool to engage athletes in thinking about their skeleton and how to keep their bones healthy.</p>	<p>1</p>	<p>For example Amazon.</p>	<p>\$29</p>
<p>Loss of a Bone Easel</p>		<p>HEALTH EDCO W43124 Loss of Bone Easel Display, 9" Length x 12" Height</p>	<p>1</p>	<p>http://www.healthedco.com/index.php/loss-of-a-bone-easel-display.html</p>	<p>\$117</p>
<p>Got Milk? / Milk Life photo backdrop banners and posters</p>		<p>Dairy Council has provided a limited number of banners and posters which can be obtained from SOI by US programs.</p>	<p>As needed</p>	<p>Contact Health Promotion Manager for SONA programs</p>	<p>No cost if ordered through your local Dairy Council</p>
<p>Cambro Handwashing Station (If no sink access)</p>		<p>4.75 Gallon Container Insulated Beverage Dispenser plus Cambro HWAPR Black Hand Washing Station</p>	<p>1</p>	<p>Cambro or Amazon</p>	<p>\$110-\$130+ shipping</p>
<p>Soap and Paper Towels</p>		<p>For use at the handwashing station.</p>	<p>Dependent on the # of athletes</p>	<p>Local store</p>	<p>varies</p>

Athlete Educational Giveaway Items

These are examples. Work with local companies to see what you might be able to get donated.

<p>Water (Bottled or via dispensers and cups)</p>		<p>Important teaching tool for hydration, nutrition, physical activity and/or sun safety stations. A water dispenser is longer lasting and reduces waste.</p>	<p>1 per athlete <i>Funds can be included in capacity grant for 50% of anticipated athlete in attendance</i></p>	<p>local grocer</p>	<p>donation</p>
<p>Fresh Fruit and Vegetables</p>		<p>Represent local food preferences, small colorful, not requiring preparation.</p>	<p>1 per athlete <i>Funds can be included in capacity grant for 50% of anticipated athlete in attendance</i></p>	<p>local grocer</p>	<p>variety</p>
<p>Dairy products lite yogurt, string cheese, containers of skim or low-fat unflavored milk</p>		<p>Have a bin of ice for yogurt, plus plastic spoons and access to trash can.</p>	<p>1 per athlete.</p>	<p>local grocer</p>	<p>variety of sugar free, low-fat or fat-free options</p>
<p>Lip Balm</p>		<p>For distribution at Sun Safety or Check-out stations.</p>	<p>1 per athlete</p>	<p>US Programs may request through online form, if available or order online.</p>	<p>varies</p>
<p>Solar Bracelets</p>		<p>For distribution at Sun Safety or Check-out stations.</p>	<p>1 per athlete <i>Funds can be included in capacity grant for 50% of anticipated athlete attendance</i></p>	<p>US Programs may request through online form, if available or order online: CustomOnlyt</p>	<p>~\$0.60 each</p>
<p>Travel Size Sunscreen (30 SPF+)</p>		<p>For distribution at Sun Safety or Check-out stations.</p>	<p>1 per athlete</p>	<p>Try to get donated.</p>	<p>varies</p>
<p>Bars of soap</p>		<p>For distribution at Handwashing station</p>	<p>1 per athlete</p>		<p>Try to get donated.</p>
<p>Plastic bucket, wash cloth, hand towel, soap</p>		<p>For distribution at Handwashing station especially in areas with limited water resources</p>	<p>1 per athlete</p>	<p>Dollar store, Amazon or Alibaba, Walmart</p>	<p>varies</p>

General Supplies

Banners - Health Promotion and Station Signs		SOI will provide 2 HP banners per program for US/Canada programs. Order from SOI.	2	For First time US-Canada programs, contact Health Promotion Manager Intl Programs (or for replacement banners), can access the files on the HP Resources Website . Individual stations banners are available on the HP Resources Website	Banners and signs provided for SONA programs. (one time) Printing costs for Intl or replacement banners can be included in Capacity Grant
Plastic baskets		Use to consolidate forms, giveaways and other materials. Helps keep HP venue tidy and organized.	4 per station check-in & check-out station. May also need for other stations.	Dollar store	~\$1-\$5 each
Colorful tablecloths		Fabric or plastic tablecloths to brighten look of venue. Design can be station specific, use solid colors if table filled with "busy" items	1 per station	local	varies
Fruit & Vegetable Balloons		Promote HP themes with reusable floating mylar balloons. Have a "party" size tank of helium or hand pumps will work but balloons won't float.	mixed set of fruits and vegetables	nutritioneducationstore.com or Amazon.com	Varies
Retractable banner stands or freestanding frame easels		Poster can be easily displayed. Pull the banner up from the bottom of the unit and attach the top bar to the back pole. Freestanding frame easels support large poster boards.	as needed, if you can't put posters on walls/tables	Check Amazon, Alibaba, Walmart and office supply stores	varies
Office Supplies – Pens, pencils, clipboards, stapler, tape, rope, zip ties, scissors, etc.		Suggest having a kit with all your office supplies that you can use for each event.	1 set of supplies	Local Store	Varies
Clear Plastic Storage Bins		To store general supplies below	Label bins to store supplies & small equipment for stations	Check Amazon, Alibaba, Walmart and home supply stores	varies
Vinyl three ring binders		Use to assemble reference materials, FAQ sheets, screener's guides for Check-out station.	One per station	Check Amazon, Alibaba, Walmart and office supply stores	varies
Trash Bags, Cleaning Supplies		Clean-up and for waste at stations	2 dozen (per 500 athletes)	Local	Varies

Health Promotion Sample Layout

Actual layout based on space size, expected numbers of athletes, hours of event.

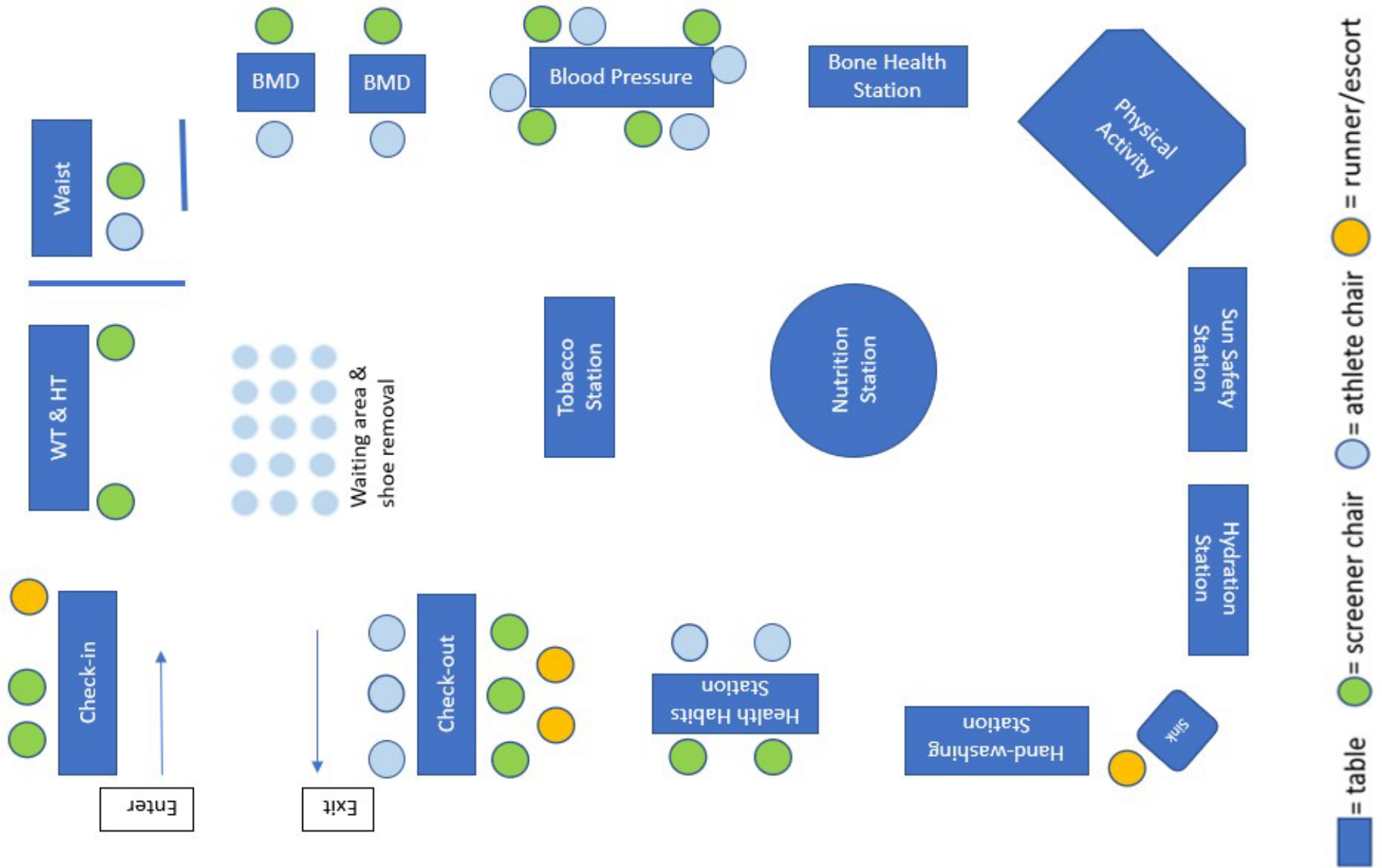

CHAPTER 2 - APPENDIX 6: HP VENUE QUALITY ASSURANCE CHECKLIST

Special Olympics
Health Promotion



Program Name: _____

Date of Review: _____

Event Location (City, State): _____

Time of Review: _____

Reviewer: _____

ACTIVITY	YES	NO	NOT APPLICABLE	COMMENTS
	standards are met	standards are not met	Unable to evaluate issue.	
SET-UP				
Signage is present and easy to follow (in appropriate languages) for athlete/coach to navigate the venue				
Banners have CDC and/or Golisano logos				
Event space adequate: room for all stations, near other athlete activities				
Venue is safe, clean, reasonable temperature and air flow. Is devoid of undue noise.				
Venue is inviting and fun (e.g., colorful and volunteers are engaging and smiling)				
Electricity available for equipment, if needed				
Flow is efficient with steady flow of athletes				
Waiting areas are present for athletes, coaches, and family members				
ACTIVITY	YES	NO	NOT APPLICABLE	COMMENTS
VOLUNTEERS	Total Number of Clinical Volunteers_____ Total Number of Non-Clinical Volunteers_____			
Training session conducted for all volunteers on site or in advance?				
Trained Clinical Director is present and provides on-site supervision.				

Volunteers are wearing HA or volunteer shirt featuring correct branding				
Volunteers are wearing name tag or credential				
General volunteers dedicated to “directing traffic”				
Volunteers have completed appropriate sign-up and Hold Harmless forms				
Adequate number of clinical volunteers for screening and Check-Out stations				
Adequate number of general volunteers				
Suitable volunteer scheduling: staggered breaks and meals; good station coverage				
Volunteer access to healthy snacks, meals and water				
STATIONS				
Check-In Station				
Adequate number of volunteer and athlete stations for each screening				
Educational messaging clear and appropriate for athletes. If not, indicate what materials or extra stations needed improvement in comments				
Height and Weight Station (BMI)				
<ul style="list-style-type: none"> The instructional height and weight posters are visible to volunteers. Professional scale used: can be zeroed; weighs up to 400 lbs.; is in .01kg/1/4 lbs. increments) 				
<ul style="list-style-type: none"> Approved height device used: stadiometer or measuring tape on wall with right-angle headboard 				
<ul style="list-style-type: none"> Scale and stadiometer are used on a hard surface. 				
Waist to Height Ratio (WHtR)				
<ul style="list-style-type: none"> Privacy screen used. 				
<ul style="list-style-type: none"> A flexible measuring tape is used. 				
<ul style="list-style-type: none"> Poster with correct waist measurement technique visible to volunteers. 				
ACTIVITY	YES	NO	NOT APPLICABLE	COMMENTS

Blood Pressure Station (BP)				
• Has documentation that accuracy of BP devices were validated prior to event				
• Has all cuff sizes: regular, pediatric/small, X-lg				
• Athletes with BP ≤160/100 are referred to event emergency medical services				
• Correct positioning of athlete poster is visible to all volunteers				
Bone Density Station				
• A SOI approved BMD device is used; device manual available for troubleshooting.				
• Only athletes 20 or older get BMD exam. Displays poster stating the same.				
• BMD area is clean (trash in container, clinic supplies and teaching props neatly displayed, machines free of dirt and debris.				
Health Habits (HH) Survey Station				
• HH Interview done at a standalone station or education stations? (comments)				
• Uses the HH graphic template or some visual cues for interview.				
Education Stations Note if station is offered and whether station was combined with another.				
• Nutrition/Healthy Eating				
• Bone Health Education				
• Hydration				
• Sun Safety				
• Tobacco Cessation				
• Handwashing				
• Additional Station(s)				
ACTIVITY	YES	NO	NOT APPLICABLE	COMMENTS
Check-Out Station				
• Check-Out materials at volunteer stations: binders with reference materials, Choose to Change cards for education stations + BP, Athlete Health Report Screener tool, Screener Reference Guides				
• HP Athlete Health Report given to athlete.				

• Athlete receives screening results and referral information when indicated.				
• Referral list of community-based service services available for athletes.				
• HAS form is collected from each athlete.				
• Educational giveaways of a reasonable quality given to athletes				
ACTIVITY	YES	NO	NOT APPLICABLE	COMMENTS
EQUIPMENT & SUPPLIES				
Adequate supply of HAS forms or tablets are available.				
If tablets are to be used, there are contingency plans for form use if power, internet failure, etc.				
Equipment arrived on time for setup.				
Functioning screening equipment is available.				
Equipment QA / validation protocols are followed and documented, before screening athletes starts				
SANITATION & UNIVERSAL PRECAUTIONS				
Gloves available and used if necessary				
Disinfecting wipes used to clean equipment and surfaces				
Trash baskets are available for stations and trash is disposed properly (smaller than 33-gallon size)				
Venue and stations are kept neat and tidy.				
HEALTH PROMOTION SPECIALIST SECTION (only if HP clinician is using QA Checklist)				
Referral criteria followed based on screening results and entered on HAS form or tablet.				
Emergency athlete referrals are addressed and documented.				

Other Notes or Observations:

Health Promotion Printing List

For event planning	Venue Layout Quality Assurance Checklist Volunteers Training cards for Shift Change	Sample HP Layout Printing checklist	Current HP HAS form Current HPCD Manual in 3 ring binder Station Signage (Banners)
BMI/ WHtR	<ul style="list-style-type: none"> • Height Poster Weight Poster color laminated, one of each per scale/stadiometer. • WHtR Measurement Poster color laminated 		
BMD	Athletes 20 and older poster		
BP	Blood pressure positioning poster , we need one for each volunteer 8x11.5 laminated sheets, so each screener is reminded of correct athlete placement. Blood Pressure Screening Guide (PDF) color, laminated, for each screener to be aware of referral guidelines, including on-site referral to medical personnel if the BP reaches the threshold.		
Health Habits Interview	Health Habits Interview Photo Guide (needed if you are offering the Health Habits Interview. Planned screening and educations, plus Check-Out should be fully staffed before offering this interview.		
Sun Safety	Instruction for safe use of sunscreen		
Hydration	Rethink your Drink bottle wraps. If you will do education on sweetened beverages at the Hydration Station, print wraps in color on hard stock and laminate. You may also use clean dry clear beverage bottles with the representative teaspoons of sugar in each. Print the PPPDS RYDP Label Cards- (1 st page is key for the sugar content).		
Check-Out	All items printed in color and inserted in plastic sleeves for each volunteer, place in Three-ring binders. Label front of binders Health Promotion Check-Out Station Resources <ul style="list-style-type: none"> • Check-Out Station Supplies and Materials Graphic • BMI FAQ (PDF) Bone Mineral Density FAQ (PDF) Blood Pressure FAQ (PDF) WHtR FAQ (PDF) FAQs are optional for volunteers to answer questions on why we offer screening. • BMI Charts (PDF): Adults, Female Youth, Male Youth • BMD Screening Reference Guide • BMI Screening Reference Guide • BP Screening Reference Guide • WHtR Screening Reference Guide • Athlete Health Report (print front to back) • Athlete Health Report Screener’s Tool (print front to back) • Health Education Posters image & C2C Cards Image for reference when counseling (print front to back) 		



Special Olympics **Health Promotion**

Chapter Three: Clinical Screening Stations



Height & Weight

Body Mass Index (BMI) Screening Station

Background Information

Special Olympics Health Promotion conducts height and weight measurements, calculates the athlete’s BMI or BMI percentile for athletes under 20 years of age, provides education about healthy weight and refers athlete for additional nutrition/medical follow-up based on Body Mass Index. The BMI is a simple index of weight for height that is commonly used to classify underweight, overweight and obesity.

BMI is a screening tool, is not a diagnostic tool. BMI screening helps predict risk of diabetes, arthritis, some cancers, and chronic disease. BMI is also used as a screening tool for body fatness. It is a tool to gather information to later ask questions, make a referral, and provide a baseline.

There are three key areas to ensure accurate measurements for athlete screening. These are

1. Athlete and equipment preparation
2. Athlete placement and measurement
3. Reading and recording measurement

Equipment and Tools

For the BMI station, you’ll need a professional medical scale and stadiometer, tools such as a BMI wheel, smart phone app, or on-line calculators to calculate BMI and determine whether the athlete is in a healthy range or not quickly and accurately.

Scale and Stadiometer Requirements



Scale Requirements (weight measurement):	Stadiometer Requirements (height measurement):
<ul style="list-style-type: none"> • Professional quality electronic digital or beam balance scale (Grade III scale) • Weighs in 0.1 kg (100 gm) or 1/4 lb increments • Weight can be ‘locked’ in • Weight is read at ‘eye level’ of measurer • Stable weighing platform- a platform large enough to support the individual being weighed • Can be easily ‘zeroed’ • Can be validated • No stature device attached • No wheels on scale • Do not use spring balance and home use scales, as they can be inaccurate which will lead to an inaccurate Body Mass Index score. 	<p>Portable stadiometer or one that is firmly mounted on a stable wall and includes:</p> <ul style="list-style-type: none"> • A vertical board with an attached English/metric rule • An easily moveable horizontal headboard that can be brought into contact with the top part of the head • A wide and stable platform or firm uncarpeted floor as the base • Firmly mounted on a stable wall • Easily read, stable tape or digital readout in 0.1cm or 1/8-inch increments <p>The measuring rod attached to a scale, or a tape affixed to the wall may not be used to measure height, as they can be inaccurate which will lead to an inaccurate Body Mass Index score.</p>

See HP Logistics and Administrative Topics ([Equipment and Supplies List – Chapter 2](#)) for information on ordering approved scales and stadiometers. One of each can be purchased with Special Olympics Healthy Athletes capacity grant or through local grants and partnerships.

Body Mass Index Tools

Tools include a **Body Mass Index Wheel**, **smart phone application**, **online calculator**, or **growth charts**

See “[How to Calculate BMI section](#)” for specifications and resources for Body Mass Index Tools.

Type	Adult BMI Tools	Pediatric BMI Tools
Body Mass Index Wheel		
There are several BMI Wheels available for purchase. Select one that represents the unit of measurement (Metric vs Imperial) you use. For pediatric athletes, have a wheel or app that calculates BMI percentiles, and that the weight and height numbers represent children, not adults. Not all BMI wheels have this feature.	 <ul style="list-style-type: none"> • Imperial (English) Wheel - Adult • Metric BMI Wheel - Adult 	 <ul style="list-style-type: none"> • Imperial (English) Wheel - Pediatric • Metric and English Wheel - Pediatric • FANTA BMI Wheel - Pediatric (only up to 18)
Smart Phone Application and Online BMI Calculators		
There are several smart phone and online Body Mass Index calculators. Using these will result in an accurate BMI result. .	<ul style="list-style-type: none"> • US Centers for Disease Control (online tool) 	<ul style="list-style-type: none"> • Pedi Quik Calc (app - iOS) • Anthro Calc (app - Android) • US Centers for Disease Control Pediatric BMI (online tool)
BMI Charts		
	Adult Chart <ul style="list-style-type: none"> • See Appendix 	Pediatric Chart <ul style="list-style-type: none"> • Boys – see Appendix • Girls – see Appendix

Station Layout – Body Mass Index:

Based on the number of athletes expected, number of volunteers, and the length of your event, your layout may change, but you will need to have a scale and stadiometer for each BMI station. **The scale and stadiometer should be on an even, hard floor surface (not on carpet/grass)** and you will need chairs/bench for athlete to take off and put on their shoes. Ensure height and weight measurement technique posters are displayed or available to the volunteers.

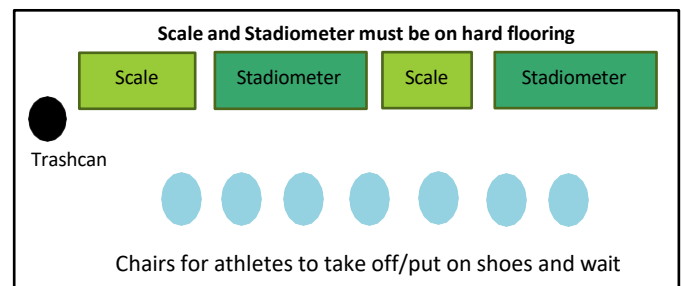

How to Measure – Body Mass Index:

To prepare for individual measurements, always be sensitive to the athlete’s privacy. Record the measurement on the form/tablet without commenting out loud or calling attention to negative results. Feel free to share the information with the athlete.

Athlete Preparation

Greet the athlete and introduce yourself. Explain to the athlete what is going to happen and the purpose of the height and weight screening. Request that athletes remove shoes, boots, caps, sports packs, jacket, hair accessories, phones, medals, and other bulky items that interfere with measurement. The Body Mass Index Screening area should have chairs where athletes can sit remove these items and be ready for their height and weight measurements.

Athlete Placement and Measurement - Height

- Step 1-Athlete placement on stadiometer-** Have the athlete stand with his/her back against the measuring surface. The feet should be flat on the floor or foot piece, with both heels comfortably together and touching the base of the vertical board. When possible, the top of the head, shoulder blades, buttocks, and heels should touch the measuring surface.
- Step 2-Measure athlete-** With the athlete looking straight ahead; slide the headboard firmly down to the top of the head compressing the hair. Be sure that the headboard is level and at right angles to the tape.

* A stool may be needed by the volunteer to read the height if the athlete is taller than the volunteer is.

Read and Record - Height

With your eyes level to the Measurement indicator (arrow) of the headboard, read the height to the nearest 0.1cm or 1/8-inch* and record the measurement on the athlete's HAS form or tablet.



Use the "[Height Measurement Technique Poster](#)" document in the appendix to help train and remind your volunteers of proper protocol for measuring height.

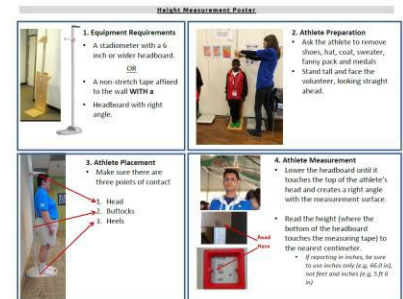

Equipment Preparation - Weight

Balance the scale at zero before weighing each athlete.

- Digital scales:** push the button to zero the scale if it does not self-zero.
- Beam balance:** move both weights left to zero before each use. If the scale does not balance at the midpoint, adjust the counterweight until it does.

Athlete Placement and Measurement - Weight

Weigh the athlete

- Digital scales:** Ask the athlete step up on the scale, wait until the digital reading has stopped and record the weight.
- Beam scales:** Ask the athlete to step up on the scale, then slide the larger weight bar to the approximate area for centering the arrow, and then slide the smaller weight bar to the right until the arrow is centered.

Read and Record - Weight

Read measurement to the nearest ounce, 0.1 kg or 1/4 lb. Record result on the HAS form or tablet.

Body Composition	
Height 170.2 cm Measure up to 0.1 cm	Height inches Measure up to 1/8 inch
Weight 106.8 kg Measure up to 0.1 kg	Weight lbs. oz. Measure up to 1/2 oz
35.66 BMI (20 years of age and over)	BMI Percentile (under 20 years of age)

Body Composition	
Height 170.2 cm Measure up to 0.1 cm	Height inches Measure up to 1/8 inch
Weight 106.8 kg Measure up to 0.1 kg	Weight lbs. oz. Measure up to 1/2 oz
35.66 BMI (20 years of age and over)	BMI Percentile (under 20 years of age)

BEST PRACTICE:

NOTE: If using a digital or balance beam scale, see chart (appendix 6) that shows how to easily convert decimals or fraction pound measurements to ounces



Use the “[Weight Measurement Technique Poster](#)” document in the appendix to help train and remind your volunteers of proper protocol for measuring height.

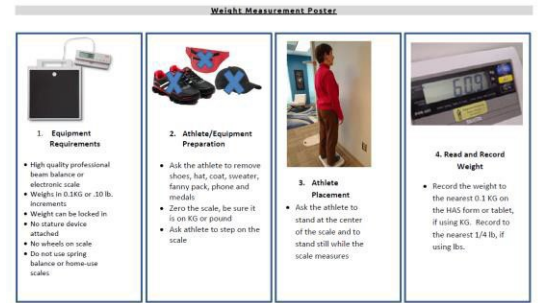

NOTE: Be sure to have the scale on level ground (preferably not on carpet). Have an area for athletes to sit down and remove their shoes close to where they will have their height and weight taken

When you are done with the measurements, thank the athlete for their assistance in gathering the height and weight. Assist them in reconnecting with their shoes and other personal items.

How to calculate an individual’s Body Mass Index:

There are several tools and online calculators to assist in calculating an individual’s Body Mass Index to and determine whether the athlete is within a healthy range or not. These include a manual calculation, Body Mass Index Wheels, smart phone apps, online calculators, or a Body Mass Index chart. The wheels and apps listed above will automatically calculate Body Mass Index, below is the manual calculation, if ever needed:

Adult

Special Olympics uses the [World Health Organization’s \(WHO\) BMI Classification for Adults](#) and the [US Centers for Disease Control BMI Classification for Children up to age 20](#).

Adult Weight Status Classification	Body Mass Index (BMI)
Underweight	<18.5
Healthy Weight	18.5 - 24.9
Overweight	≥ 25
Obese	≥ 30

Pediatric (birth to the 20th birthday)

A Body Mass Index for children is age and gender specific and is expressed as a Body Mass Index (BMI) percentile. The first step is to calculate the Body Mass Index as described above. The second step is to determine the Body Mass Index percentile. Health Promotion uses the Centers for Disease Control Classification for Body Mass Index. Resources available to determine the Body Mass Index percentile include:

- Pediatric Body Mass Index calculator wheel
- Online Body Mass Index calculators
- Pediatric growth charts which are gender specific and include the BMI percentile

The Healthy Athletes Software (HAS) will calculate the Body Mass Index/Body Mass Index percentile when the data is entered in the tablet or as direct data entry is completed.

Pediatric Weight Status Classification	Body Mass Index Percentile Range
Underweight	Less than the 5th percentile
Healthy weight	5th percentile to less than the 85th percentile
Overweight	85th to less than the 95th percentile
Obese	Equal to or greater than the 95th percentile



See the appendix for the [Summary Reference Guide- Pediatric, Adolescent and Adult Body Mass Index](#). It illustrates the Body Mass Index Categories and Referral Guidelines for each age group. This will be discussed at the check-out station.

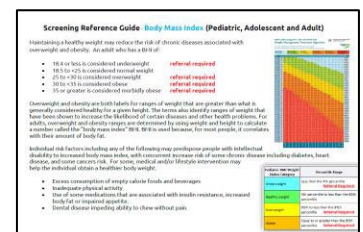

Body Mass Index Challenges:

Issue	Correction
Scale and stadiometer not functioning	<ul style="list-style-type: none"> ● Make sure the scale is plugged into a wall outlet or that the batteries work. ● Set measuring devices on hard, uncarpeted surface, not grass or dirt. ● Reset the scale to zero.
Athlete not comfortable	<p>Ensure that:</p> <ul style="list-style-type: none"> ● there are chairs in the area for the athlete to comfortably take shoes off/put on. ● there is an area for the athlete to store their personal belongings, and ● you are slowly and clearly explaining the process. <ul style="list-style-type: none"> ➤ Have athlete watch a volunteer or another athlete be screened, so they can see the procedure. ➤ Ask the athlete if they are ill or in pain. You may have to refer the athlete to the medical event staff if they are ill. ➤ If athlete doesn't want to complete the process, say "that's okay" and move to next station.
Athlete cannot be weighed or measured physical limitations	See Alternative Methods for Measuring Height and Weight in Chapter 3 appendix.

Frequent causes of error in measurement:

- Using incorrect equipment. Do not measure using the height rod on scales. Bathroom scales should not be used to weigh.
- Misreading the measurement. Practice reading the fractional division of inches/centimeters or ounces/kgs. on your equipment. Inform volunteers if you will use English or Metric. Don't mix them.
- Didn't to balance scales at zero before each use. Follow the described procedure for balancing scales before measuring everyone.
- Not positioning the athlete properly. Ensure that feet are flat on the floor and heels touch the back of the stadiometer.
- Measuring height with shoes on and weight with excess clothing. Measure athletes without shoes and excess clothing, fanny packs and other gear.
- Didn't use a right-angle headboard when measuring height. Ensure your venue has this equipment and that it is used each time height is measured.
- Recording errors on HAS form or tablet. Only write English measures in the English line and metric in the metric line. Metric height uses centimeters not millimeters.

BEST PRACTICE:

Make sure measurements are accurate:

- Use the correct devices and check them often for accuracy.
- Following standard measuring procedures.

Body Mass Index Quality Assurance

Prior to each event as the station is being set up, the Clinical Director should assign a volunteer to follow the Quality Assurance Checklist for the station to ensure the equipment and station set is correct.

Equipment Set up

- ✓ Scale plugged in or batteries work
- ✓ Set on flat surface
- ✓ Close to stadiometer
- ✓ Stadiometer- measurement numbers line up on both sides
- ✓ Set on flat surface
- ✓ Close to scale
- ✓ Chairs in area for athlete to take on/off shoes

Quality Assurance

- ✓ Set a regularly scheduled time for quality assurance observation of measurements
- ✓ Validate equipment before the training session
- ✓ Review the manual materials related to weighing and measuring before training
- ✓ Establish measurement teams of two individuals
- ✓ Each team completes a height and weight on two athlete- compare results

CHAPTER 3

BODY MASS INDEX

APPENDIX

1. Alternative Methods for Measuring Height and Weight
2. Summary Reference Guide- Pediatric, Adolescent and Adult Body Mass Index
3. Body Mass Index Growth Charts
4. Body Mass Index Posters
5. Equipment Resources and Body Mass Index Formula and Calculation
6. Conversion for Scales and Metrics
7. Frequently Asked Questions - Body Mass Index
8. Volunteer Training Tool – Body Mass Index
9. Reference – Body Mass Index

CHAPTER 3 BMI APPENDIX 1: Alternative Methods for Measuring Height and Weight

If the athlete has limitations that make standard procedures impossible, refer below alternate methods for taking weight and height measurements.

Arm Span Arm span can be used to estimate a person's stature. Arm-span is measured from the tip of the middle finger on one hand to the tip of the middle finger on the other hand, with arms outstretched as far as possible during measurement. This measurement is preferably done with an anthropometer, a straight rod which has measurements etched on it. There is an immobile tab at one end and a sliding tab at the other for the middle fingertips to touch (similar to an adjustable curtain rod). An expandable tape measure is used if an anthropometer is not available. Arm span has been found to correlate directly to stature.



Knee Height Stature can be estimated from knee height when standing height cannot be measured. The knee height is measured with a sliding broad-blade caliper, such as the Ross® Knee Height Caliper. With the subject lying on his/her back, both the left knee and ankle should be bent to a 90-degree angle. The fixed blade of the caliper is placed under the heel and the sliding blade is pressed down against the thigh about 2 inches behind the knee cap. The shaft of the caliper is held parallel to the shaft of the tibia, and pressure is applied to compress the tissue. The average of two measurements is converted to stature (cm) using one of the following equations:

6-18 years	19 - 59 years
White Males: Stature = (knee height in cm x 2.22) + 40.54	White Males: Stature = (knee height in cm x 1.88) + 71.85
Black Males: Stature = (knee height in cm x 2.18) + 39.60	Black Males: Stature = (knee height in cm x 1.79) + 73.42
White Females: Stature = (knee height in cm x 2.15) + 43.21	White Females: Stature = (knee height in cm x 1.86) – (age in yrs. x 0.05) + 70.25
Black Females: Stature = (knee height in cm x 2.02) + 46.59	Black Females: Stature = (knee height in cm x 1.86) – (age in yrs. x 0.06) + 68.10

Sitting Height and Crown-Rump Length

Sitting height or crown-rump length may be used when children are unable to stand or have severe contractures. A standard recumbent length board and stadiometer are the measuring devices. The only additional equipment needed for these measures is a sitting base for sitting height. Using the sitting surface and a wall mounted stadiometer, the child sits on the base as erect as possible with the buttocks, shoulders and head in contact with the backboard of the stadiometer. It is ideal to have the legs hanging freely, hands resting on thighs, and knees pointed straight ahead. The head is positioned in the same manner as when doing a standing height, and the headboard is brought down for the measurement. Repeat the measurement for accuracy.

After the measurement, the height of the sitting surface is subtracted from the reading to estimate sitting height. Sitting height percentiles are available for assessment purposes and are included in this handout. It is also possible to record the sitting height on the CDC growth charts and over time the series of measurements may indicate a pattern of growth, even though a percentile will not be indicated.

For crown-rump length the child lies on a recumbent length board. The head is positioned as in doing a normal length. The legs are raised so that the thighs are at a 90-degree angle to the board and held in that position during the measurement. The sliding footboard is brought up against the buttocks with firm pressure and the reading is taken. It should be repeated for accuracy. *Adapted from NC Nutrition Services Section- Pediatric Nutrition Course 12/08*

Screening Reference Guide - **Body Mass Index (Pediatric, Adolescent and Adult)**

Maintaining a healthy weight may reduce the risk of chronic diseases associated with overweight and obesity. An adult who has a BMI of:

- 18.4 or less is considered underweight **referral required**
- 18.5 to <25 is considered normal weight
- 25 to <30 is considered overweight **referral required**
- 30 to <35 is considered obese **referral required**
- 35 or greater is considered morbidly obese **referral required**

Overweight and obesity are both labels for ranges of weight that are greater than what is generally considered healthy for a given height. The terms also identify ranges of weight that have been shown to increase the likelihood of certain diseases and other health problems. For adults, overweight and obesity ranges are determined by using weight and height to calculate a number called the "body mass index" BMI. BMI is used because, for most people, it correlates with their amount of body fat.

Individual risk factors including any of the following may predispose people with intellectual disability to increased body mass index, with concurrent increase risk of some chronic disease including diabetes, heart disease, and some cancers risk. For some, medical and/or lifestyle intervention may help the individual obtain a healthier body weight.

- Excess consumption of empty calorie foods and beverages
- Inadequate physical activity
- Use of some medications that are associated with insulin resistance, increased body fat or impaired appetite.
- Dental disease impeding ability to chew without pain.

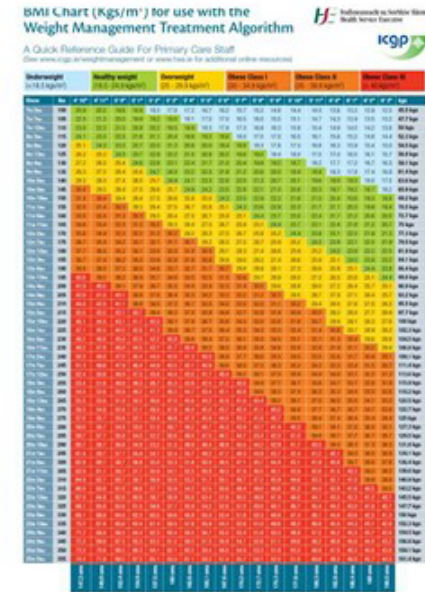

Pediatric BMI Weight Status Category	Percentile Range
Underweight	Less than the 5th percentile Referral Required
Healthy weight	5th percentile to less than the 85th percentile
Overweight	85th to less than the 95th percentile Referral Required
Obese	Equal to or greater than the 95th percentile Referral Required

CHAPTER 3 BMI APPENDIX 2: BMI Growth Charts - ADULTS

BMI Chart (Kgs/m²) for use with the Weight Management Treatment Algorithm

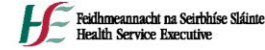

A Quick Reference Guide For Primary Care Staff
(See www.icgp.ie/weightmanagement or www.hse.ie for additional online resources)

Underweight (<18.5 kgs/m ²)		Healthy weight (18.5 - 24.9 kgs/m ²)					Overweight (25 - 29.9 kgs/m ²)				Obese Class I (30 - 34.9 kgs/m ²)			Obese Class II (35 - 39.9 kgs/m ²)			Obese Class III (> 40 kgs/m ²)			
Stone	lbs	4' 10"	4' 11"	5' 0"	5' 1"	5' 2"	5' 3"	5' 4"	5' 5"	5' 6"	5' 7"	5' 8"	5' 9"	5' 10"	5' 11"	6' 0"	6' 1"	6' 2"	6' 3"	kgs
7st 2lbs	100	20.9	20.2	19.6	18.9	18.3	17.8	17.2	16.7	16.2	15.7	15.2	14.8	14.4	14.0	13.6	13.2	12.9	12.5	45.5 kgs
7st 7lbs	105	22.0	21.3	20.5	19.9	19.2	18.6	18.1	17.5	17.0	16.5	16.0	15.5	15.1	14.7	14.3	13.9	13.5	13.2	47.7 kgs
7st 12lbs	110	23.0	22.3	21.5	20.8	20.2	19.5	18.9	18.3	17.8	17.3	16.8	16.3	15.8	15.4	14.9	14.5	14.2	13.8	50 kgs
8st 3lbs	115	24.1	23.3	22.5	21.8	21.1	20.4	19.8	19.2	18.6	18.0	17.5	17.0	16.5	16.1	15.6	15.2	14.8	14.4	52.3 kgs
8st 8lbs	120	25.1	24.3	23.5	22.7	22.0	21.3	20.6	20.0	19.4	18.8	18.3	17.8	17.3	16.8	16.3	15.9	15.4	15.0	54.5 kgs
8st 13lbs	125	26.2	25.3	24.5	23.7	22.9	22.2	21.5	20.8	20.2	19.6	19.0	18.4	18.0	17.5	17.0	16.5	16.1	15.7	56.8 kgs
9st 4lbs	130	27.2	26.3	25.4	24.6	23.8	23.1	22.4	21.7	21.0	20.4	19.8	19.2	18.7	18.2	17.7	17.2	16.7	16.3	59.1 kgs
9st 9lbs	135	28.3	27.3	26.4	25.6	24.7	24.0	23.2	22.5	21.8	21.2	20.6	20.0	19.4	18.9	18.3	17.8	17.4	16.9	61.4 kgs
10st 0lbs	140	29.3	28.3	27.4	26.5	25.7	24.9	24.1	23.3	22.6	22.0	21.3	20.7	20.1	19.6	19.0	18.5	18.0	17.5	63.6 kgs
10st 5lbs	145	30.4	29.3	28.4	27.5	26.6	25.7	24.9	24.2	23.5	22.8	22.1	21.5	20.8	20.3	19.7	19.2	18.7	18.2	65.9 kgs
10st 10lbs	150	31.4	30.4	29.4	28.4	27.5	26.6	25.8	25.0	24.3	23.5	22.9	22.2	21.6	21.0	20.4	19.8	19.3	18.8	68.2 kgs
11st 1lbs	155	32.5	31.4	30.3	29.3	28.4	27.5	26.7	25.8	25.1	24.3	23.6	22.9	22.3	21.7	21.1	20.5	19.9	19.4	70.5 kgs
11st 6lbs	160	33.5	32.4	31.3	30.3	29.3	28.4	27.5	26.7	25.9	25.1	24.4	23.7	23.0	22.4	21.7	21.2	20.6	20.0	72.7 kgs
11st 11lbs	165	34.6	33.4	32.3	31.2	30.2	29.3	28.4	27.5	26.7	25.9	25.1	24.4	23.7	23.1	22.4	21.8	21.2	20.7	75 kgs
12st 2lbs	170	35.6	34.4	33.3	32.2	31.2	30.2	29.2	28.3	27.5	26.7	25.9	25.2	24.4	23.8	23.1	22.5	21.9	21.3	77.3 kgs
12st 7lbs	175	36.7	35.4	34.2	33.1	32.1	31.1	30.1	29.2	28.3	27.5	26.7	25.9	25.2	24.5	23.8	23.1	22.5	21.9	79.5 kgs
12st 12lbs	180	37.7	36.4	35.2	34.1	33.0	32.0	31.0	30.0	29.1	28.3	27.4	26.6	25.9	25.2	24.5	23.8	23.2	22.5	81.8 kgs
13st 3lbs	185	38.7	37.4	36.2	35.0	33.9	32.8	31.8	30.8	29.9	29.0	28.2	27.4	26.6	25.9	25.1	24.5	23.8	23.2	84.1 kgs
13st 8lbs	190	39.8	38.5	37.2	36.0	34.8	33.7	32.7	31.7	30.7	29.8	28.9	28.1	27.3	26.6	25.8	25.1	24.4	23.8	86.4 kgs
13st 13lbs	195	40.8	39.5	38.2	36.9	35.7	34.6	33.5	32.5	31.5	30.6	29.7	28.9	28.0	27.3	26.5	25.8	25.1	24.4	88.6 kgs
14st 4lbs	200	41.9	40.5	39.1	37.9	36.7	35.5	34.4	33.4	32.3	31.4	30.5	29.6	28.8	28.0	27.2	26.4	25.7	25.1	90.9 kgs
14st 9lbs	205	42.9	41.5	40.1	38.8	37.6	36.4	35.3	34.2	33.2	32.2	31.2	30.3	29.5	28.7	27.9	27.1	26.4	25.7	93.2 kgs
15st 0lbs	210	44.0	42.5	41.1	39.8	38.5	37.3	36.1	35.0	34.0	33.0	32.0	31.1	30.2	29.4	28.5	27.8	27.0	26.3	95.5 kgs
15st 5lbs	215	45.0	43.5	42.1	40.7	39.4	38.2	37.0	35.9	34.8	33.7	32.8	31.8	30.9	30.0	29.2	28.4	27.7	26.9	97.7 kgs
15st 10lbs	220	46.1	44.5	43.1	41.7	40.3	39.1	37.8	36.7	35.6	34.5	33.5	32.6	31.6	30.7	29.9	29.1	28.3	27.6	100 kgs
16st 1lbs	225	47.1	45.5	44.0	42.6	41.2	39.9	38.7	37.5	36.4	35.3	34.3	33.3	32.4	31.4	30.6	29.7	28.9	28.2	102.3 kgs
16st 6lbs	230	48.2	46.6	45.0	43.5	42.2	40.8	39.6	38.4	37.2	36.1	35.0	34.0	33.1	32.1	31.3	30.4	29.6	28.8	104.5 kgs
16st 11lbs	235	49.2	47.6	46.0	44.5	43.1	41.7	40.4	39.2	38.0	36.9	35.8	34.8	33.8	32.8	31.9	31.1	30.2	29.4	106.8 kgs
17st 2lbs	240	50.3	48.6	47.0	45.4	44.0	42.6	41.3	40.0	38.8	37.7	36.6	35.5	34.5	33.5	32.6	31.7	30.9	30.1	109.1 kgs
17st 7lbs	245	51.3	49.6	47.9	46.4	44.9	43.5	42.1	40.8	39.6	38.5	37.3	36.3	35.2	34.2	33.3	32.4	31.5	30.7	111.4 kgs
17st 12lbs	250	52.4	50.6	48.9	47.3	45.8	44.4	43.0	41.7	40.4	39.2	38.1	37.0	35.9	34.9	34.0	33.1	32.2	31.3	113.6 kgs
18st 3lbs	255	53.4	51.6	49.9	48.3	46.7	45.3	43.9	42.5	41.2	40.0	38.9	37.7	36.7	35.6	34.7	33.7	32.8	31.9	115.9 kgs
18st 8lbs	260	54.5	52.6	50.9	49.2	47.7	46.2	44.7	43.4	42.1	40.8	39.6	38.5	37.4	36.3	35.3	34.4	33.5	32.6	118.2 kgs
18st 13lbs	265	55.5	53.6	51.9	50.2	48.6	47.0	45.6	44.2	42.9	41.6	40.4	39.2	38.1	37.0	36.0	35.0	34.1	33.2	120.5 kgs
19st 4lbs	270	56.5	54.6	52.8	51.1	49.5	47.9	46.4	45.0	43.7	42.4	41.1	40.0	38.8	37.7	36.7	35.7	34.7	33.8	122.7 kgs
19st 9lbs	275	57.6	55.7	53.8	52.1	50.4	48.8	47.3	45.9	44.5	43.2	41.9	40.7	39.5	38.4	37.4	36.4	35.4	34.4	125 kgs
20st 0lbs	280	58.6	56.7	54.8	53.0	51.3	49.7	48.2	46.7	45.3	43.9	42.7	41.4	40.3	39.1	38.1	37.0	36.0	35.1	127.3 kgs
20st 5lbs	285	59.7	57.7	55.8	54.0	52.2	50.6	49.0	47.5	46.1	44.7	43.4	42.2	41.0	39.8	38.7	37.7	36.7	35.7	129.5 kgs
20st 10lbs	290	60.7	58.7	56.8	54.9	53.2	51.5	49.9	48.4	46.9	45.5	44.2	42.9	41.7	40.5	39.4	38.3	37.3	36.3	131.8 kgs
21st 1lbs	295	61.8	59.7	57.7	55.9	54.1	52.4	50.7	49.2	47.7	46.3	44.9	43.7	42.4	41.2	40.1	39.0	38.0	36.9	134.1 kgs
21st 6lbs	300	62.8	60.7	58.7	56.8	55.0	53.3	51.6	50.0	48.5	47.1	45.7	44.4	43.1	41.9	40.8	39.7	38.6	37.6	136.4 kgs
21st 11lbs	305	63.9	61.7	59.7	57.7	55.9	54.1	52.5	50.9	49.3	47.9	46.5	45.1	43.9	42.6	41.5	40.3	39.2	38.2	138.6 kgs
22st 2lbs	310	64.9	62.7	60.7	58.7	56.8	55.0	53.3	51.7	50.1	48.7	47.2	45.9	44.6	43.3	42.1	41.0	39.9	38.8	140.9 kgs
22st 7lbs	315	66.0	63.8	61.6	59.6	57.7	55.9	54.2	52.5	50.9	49.4	48.0	46.6	45.3	44.0	42.8	41.6	40.5	39.5	143.2 kgs
22st 12lbs	320	67.0	64.8	62.6	60.6	58.7	56.8	55.0	53.4	51.8	50.2	48.8	47.4	46.0	44.7	43.5	42.3	41.2	40.1	145.5 kgs
23st 3lbs	325	68.1	65.8	63.6	61.5	59.6	57.7	55.9	54.2	52.6	51.0	49.5	48.1	46.7	45.4	44.2	43.0	41.8	40.7	147.7 kgs
23st 8lbs	330	69.1	66.8	64.6	62.5	60.5	58.6	56.8	55.0	53.4	51.8	50.3	48.8	47.4	46.1	44.8	43.6	42.5	41.3	150 kgs
23st 13lbs	335	70.2	67.8	65.6	63.4	61.4	59.5	57.6	55.9	54.2	52.6	51.0	49.6	48.2	46.8	45.5	44.3	43.1	42.0	152.3 kgs
24st 4lbs	340	71.2	68.8	66.5	64.4	62.3	60.4	58.5	56.7	55.0	53.4	51.8	50.3	48.9	47.5	46.2	45.0	43.7	42.6	154.5 kgs
24st 9lbs	345	72.3	69.8	67.5	65.3	63.2	61.2	59.3	57.5	55.8	54.1	52.6	51.1	49.6	48.2	46.9	45.6	44.4	43.2	156.8 kgs
25st 0lbs	350	73.3	70.8	68.5	66.3	64.1	62.1	60.2	58.4	56.6	54.9	53.3	51.8	50.3	48.9	47.6	46.3	45.0	43.8	159.1 kgs
25st 5lbs	355	74.4	71.9	69.5	67.2	65.1	63.0	61.1	59.2	57.4	55.7	54.1	52.5	51.0	49.6	48.2	46.9	45.7	44.5	161.4 kgs



CHAPTER 3 BMI APPENDIX 3: BMI Growth Charts – YOUTH (less than age 20)

Chart for Boys

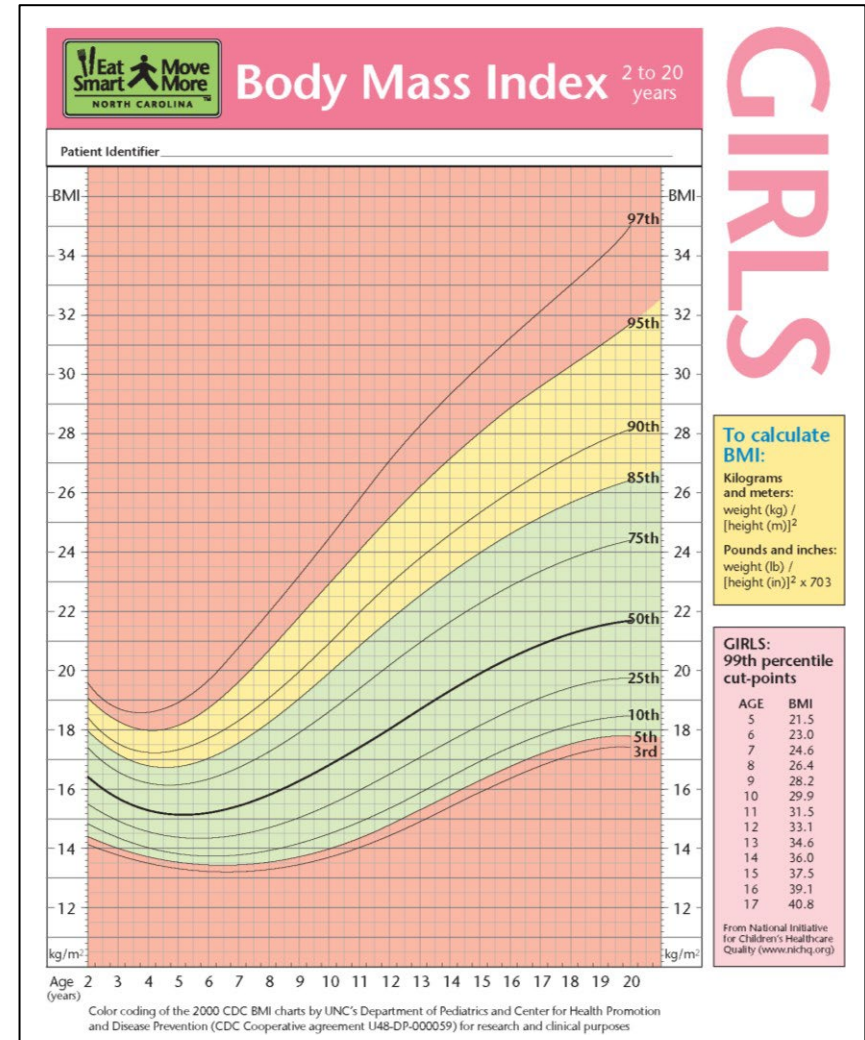
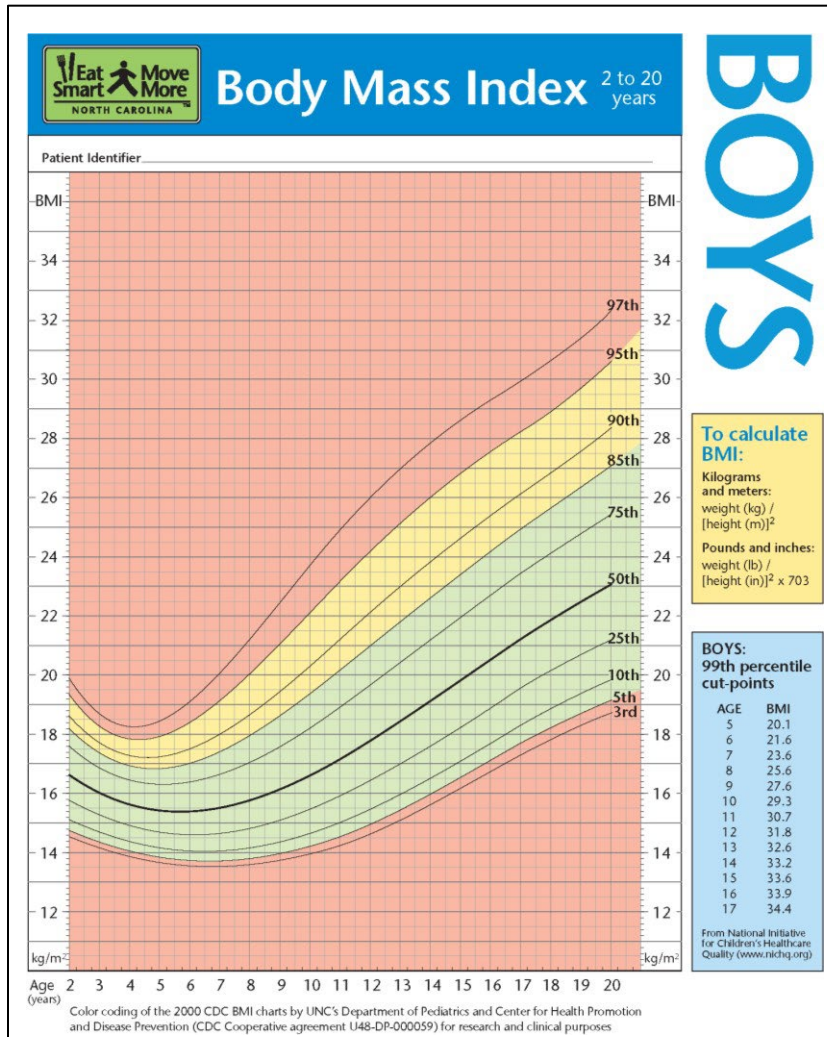
Chart for Girls

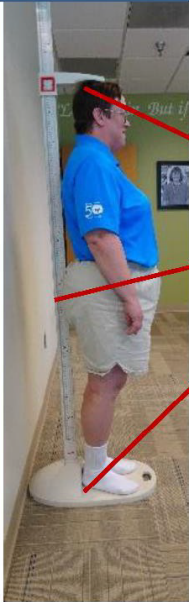
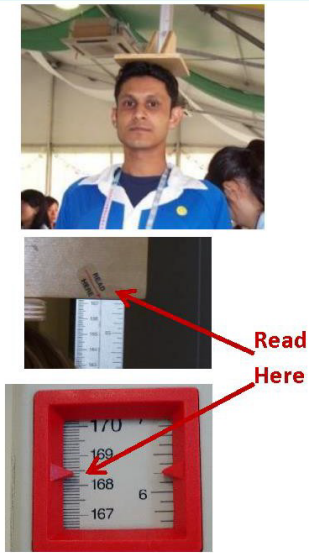

Height Measurement Poster

 <p>1. Equipment Requirements</p> <ul style="list-style-type: none"> • A stadiometer with a 6 inch or wider headboard. <p style="text-align: center;"><u>OR</u></p> <ul style="list-style-type: none"> • A non-stretch tape affixed to the wall WITH a • Headboard with right angle. 	<p>2. Athlete Preparation</p> <ul style="list-style-type: none"> • Ask the athlete to remove shoes, hat, coat, sweater, fanny pack and medals • Stand tall and face the volunteer, looking straight ahead. 
<p>3. Athlete Placement</p> <ul style="list-style-type: none"> • Make sure there are three points of contact  <ol style="list-style-type: none"> 1. Head 2. Buttocks 3. Heels 	<p>4. Athlete Measurement</p> <ul style="list-style-type: none"> • Lower the headboard until it touches the top of the athlete's head and creates a right angle with the measurement surface. • Read the height (where the bottom of the headboard touches the measuring tape) to the nearest centimeter. <ul style="list-style-type: none"> • <i>If reporting in inches, be sure to use inches only (e.g, 66.0 in), not feet and inches (e.g, 5 ft 6 in)</i> 

Weight Measurement Poster



1. Equipment Requirements

- High quality professional beam balance or electronic scale
- Weighs in 0.1KG or .10 lb. increments
- Weight can be locked in
- No stature device attached
- No wheels on scale
- Do not use spring balance or home-use scales



2. Athlete/Equipment Preparation

- Ask the athlete to remove shoes, hat, coat, sweater, fanny pack, phone and medals
- Zero the scale, be sure it is on KG or pound
- Ask athlete to step on the scale



3. Athlete Placement

- Ask the athlete to stand at the center of the scale and to stand still while the scale measures



4. Read and Record Weight

- Record the weight to the nearest 0.1 KG on the HAS form or tablet, if using KG. Record to the nearest 1/4 lb, if using lbs.

NOTE: Be sure to have the scale on level ground (preferably not on carpet). Have an area for athletes to sit down and remove their shoes close to where they will have their height and weight taken

CHAPTER 3 BMI APPENDIX 5: Suggested Equipment Resources

Stadiometer

SECA 213 Portable Height Measure- Metric and English. Available directly from [Seca](#): website lists international offices. Purchase of a SECA carrying case (SECA 412) to store and protect the equipment. Also available from Amazon, Walmart, Perspective Enterprises and medical equipment suppliers

Perspective Enterprises Portable Adult Measuring Unit and Carrying Case (English – Metric available in UK) Available directly from [SECA](#):

[Leicester Height Measure Mk II](#)

Scale

[Seca](#) 869 Flat Scale with Remote Display. Recommend purchase of a Seca carrying case (SECA 421) to store and protect the equipment.





[Tanita](#) WB 800-AS. Purchase a Tanita carrying case (Tanita C-100) to store and protect the equipment. Tanita equipment also available from Amazon and Medical Equipment Suppliers.

If you have questions or concerns regarding the equipment and supplies you are using, please contact [the Health Promotion Manager](#) and share photos of the item(s).

Body Mass Index Formula and Calculation

Measurement Units	Formula and Calculation
Metric Kilograms and meters/or centimeters	<p>Formula: weight (kg) / [height (m)]²</p> <p>With the metric system, the formula for BMI is weight in kilograms divided by height in meters squared. Since height is commonly measured in centimeters, divide height in centimeters by 100 to obtain height in meters.</p> <p>Example: Weight = 68 kg, Height = 165 cm (1.65 m)</p> <p>Calculation: $68 \div (1.65)^2 = 24.98$</p>
Imperial/English Pounds and inches	<p>Formula: weight (lb) / [height (in)]² x 703</p> <p>Calculate BMI by dividing weight in pounds (lbs) by height in inches (in) squared and multiplying by a conversion factor of 703.</p> <p>Example: Weight = 150 lbs, Height = 5'5" (65")</p> <p>Calculation: $[150 \div (65)^2] \times 703 = 24.96$</p>

Body Mass Index Station Actions and Referral for adults ages ≤ age 18

<18.5 – Adults <5 th - Youth	18.5-24.9 Adults and 5 th – 84 th Youth	25.0-29 Adults 85 th – 94 th Youth	>30 Adult >95 th Youth
underweight 	healthy 	overweight 	obese 
Referral		Referral	Referral

Imperial Measurements

Balance beam scale: Usually balance beam scales measure to $\frac{1}{4}$ pound and thus adults and children weighed on these scales will have results that must be converted to ounces. Read the result to the nearest quarter pound, if the result is exactly between two quarter pound increments, round down to the last full quarter pound. Then convert to ounces.

Balance Beam Read-out:	Record as:
$\frac{1}{4}$ pound	4 ounces
$\frac{1}{2}$ pound	8 ounces
$\frac{3}{4}$ pound	12 ounces

Digital Scale: Typically, a digital scale will display as pounds and 1/10th pounds. Convert to ounces following the table below:

Digital Readout:	Record as
.0	0 ounces
.1	2 ounces
.2	3 ounces
.3	5 ounces
.4	6 ounces
.5	8 ounces
.6	10 ounces
.7	11 ounces
.8	13 ounces
.9	14 ounces

CHAPTER 3 BMI APPENDIX 7: Frequently Asked Questions

<p>What is a Body mass index?</p>	<p>Body Mass Index or BMI is a tool for deciding if a person has an appropriate body weight. It measures a person's weight in relation to their height. This screening tool can indicate if a person is underweight, at a healthy weight, has excess weight, or is obese. If a person's BMI is outside of the healthy range, their health risks may increase significantly. Carrying too much weight can lead to a variety of health conditions, such as type 2 diabetes, high blood pressure, and cardiovascular problems. Underweight can increase risks of anemia, malnutrition, osteoporosis.</p>
<p>What does BMI tell us?</p>	<p>According to the World Health Organization and US National Institutes of Health (NIH), a BMI of:</p> <ul style="list-style-type: none"> • less than 18.5 means that a person is underweight • between 18.5 and 24.9 is normal healthy weight • between 25 and 29.9 is overweight • over 30 indicates obesity
<p>Why is BMI for children and teens</p>	<p>In children and teens, BMI is used to find out if a child or teen is underweight, a normal healthy weight, overweight, or obese. A child's body size changes with age and girls and boys differ in their amount of body fat as they mature. Therefore, BMI is calculated using height and weight, then the BMI number is plotted on to determine the percentile range for their age and gender (Z-score).</p>
<p>Why is your BMI important?</p>	<p>BMI is used to assess risk for the general population. Generally, as a person's BMI increases so does the risk of certain diseases. BMI doesn't distinguish between body fat and lean tissue, nor the location of body fat.</p>
<p>How useful is BMI?</p>	<p>BMI, used for over 100 years, helps health professionals decide if a patient is overweight or underweight. However, BMI does not measure overall fat or lean (muscle).</p>
<p>What are the benefits of being at a healthy weight</p>	<p>A healthy weight reduces the risk of the chronic disease, and results in:</p> <ul style="list-style-type: none"> • fewer joint and muscle pains • increased energy and ability to join in more activities • improved regulation of bodily fluids and blood pressure • reduced burden on the heart and circulatory system • improved sleep
<p>What kinds of food tend to increase weight gain?</p>	<p>Foods that are low in nutrient density (high in calories compared to nutrients) include:</p> <ul style="list-style-type: none"> • fast foods including fried foods, such as French fries • foods with added sugar, like baked goods, ready-made breakfast cereals, cookies, sauces and condiments and many canned and packaged food items • fatty and processed meats and full or reduced fat dairy products • sweetened juices, sodas, and alcoholic drinks • processed foods made with refined grains, such as bread and bagels • make half your plate fruit and vegetables; watch portion sizes
<p>What are the benefits of being at a healthy weight</p>	<p>A healthy weight reduces the risk of the chronic disease, and results in:</p> <ul style="list-style-type: none"> • fewer joint and muscle pains • increased energy and ability to join in more activities • improved regulation of bodily fluids and blood pressure • reduced burden on the heart and circulatory system • improved sleep patterns
<p>What kinds of exercise help people to maintain a healthy weight?</p>	<p>No matter what exercise routine you follow, it should include some aerobic or cardiovascular exercise. Aerobic exercises get your heart rate up and your blood pumping. These exercises may include walking, jogging, cycling, swimming, court sports, dancing and vigorous house and yard work. Strength training builds muscle which burns more calories and helps improve weight status.</p>
<p>How do you maintain your ideal BMI?</p>	<p>Maintaining a healthy BMI takes work. It's important to exercise at least 60-90 minutes most days of the week at moderate intensity. Staying hydrated and eat nutrient rich diet are equally important. If your BMI is over 25, look at and adjust your food choices caloric increase your exercise. Access community-based services and public health departments for programs that help people maintain a healthy weight, e.g., Diabetes Prevention Programs, sports and exercise programs through local parks and recreation, community walking and exercise programs, food and nutrition services, emergency food programs, grocery store nutrition tours and education, free healthy cooking classes.</p>

CHAPTER 3 BMI APPENDIX 9: References

1. US Centers for Disease Control
 - a. <https://www.cdc.gov/healthyweight/assessing/bmi/>
 - b. <https://www.cdc.gov/obesity/resources/index.html>
2. World Health Organization
 - a. <http://www.euro.who.int/en/health-topics/disease-prevention/nutrition/a-healthy-lifestyle/body-mass-index-bmi>
 - b. https://www.who.int/growthref/who2007_bmi_for_age/en/
 - c. <http://www.euro.who.int/en/health-topics/noncommunicable-diseases/obesity>
3. Food and Nutrition Technical Assistance Project (FANTA)
 - a. <https://www.fantaproject.org/sites/default/files/resources/MODULE-6-FANTA-Anthropometry-Guide-May2018.pdf>
4. Maternal and Child Health Bureau Growth Chart Training Modules
 - a. <https://depts.washington.edu/growth/index.htm>

Check your county's Ministry of Health for local information on Body mass Index and Healthy Weight.



Waist Height Ratio

Waist Height Ratio (WHtR) Screening Station

Background Information

Waist to Height Ratio is an excellent tool to better predict cardiovascular risk factors. The WHtR can be used for adults and children. It is a good indicator of central body adiposity. It is not age dependent and can be used across all populations.

This measurement should be taken after the athlete's height and weight are measured and entered on the HAS form or tablet.

Equipment and Tools

For the Waist Height Ratio station, you will need a flexible tape measure, tools such as a smart phone calculator or on-line calculator to quickly and accurately calculate the WHtR and determine whether the athlete is in a healthy range or not.

Read and Record- Record the measurement on the athlete's HAS form or tablet.

Waist Circumference ____ cm ____ inches
WHtR _____
Referral made for WHtR <input type="radio"/> Yes <input type="radio"/> No

WHtR Resources

Tape Measure																
Tape Measure (Imperial or Metric). Specifications: 0-300 cm/0-120 inches (flexible vinyl or cloth)																
Online WHtR Calculators																
<ul style="list-style-type: none"> There are several online WHtR calculators. Using these will result in an accurate determination or Use a calculator to determine the ratio. 	<ul style="list-style-type: none"> Online Calculators- both use Imperial and Metric https://www.omnicalculator.com/health/waist-height-ratio#shape-chart-based-on-waist-to-height-ratio https://www.bmi-calculator.net/waist-to-height-ratio-calculator/ 															
WHtR Chart																
See appendix for the Screening Reference Guide WHtR Ratio to illustrate the categories and Referral Guidelines. The WHtR results will be calculated and discussed at Check-Out.	<table border="1"> <caption>Waist-to-Height Ratio Chart Males and Females ≥ age 5</caption> <thead> <tr> <th>WHtR Value</th> <th>Classification</th> <th>Action</th> </tr> </thead> <tbody> <tr> <td>.4 or less</td> <td>Slender</td> <td>Referral</td> </tr> <tr> <td>.4 -.5</td> <td>Healthy</td> <td></td> </tr> <tr> <td>.5 - .6</td> <td>High central fat</td> <td>Referral</td> </tr> <tr> <td>≥.6</td> <td>Very high central fat</td> <td>Referral</td> </tr> </tbody> </table>	WHtR Value	Classification	Action	.4 or less	Slender	Referral	.4 -.5	Healthy		.5 - .6	High central fat	Referral	≥.6	Very high central fat	Referral
WHtR Value	Classification	Action														
.4 or less	Slender	Referral														
.4 -.5	Healthy															
.5 - .6	High central fat	Referral														
≥.6	Very high central fat	Referral														

Station Layout- WHtR

Based on the number of athletes expected, number of volunteers and length of your event, your layout may change, but you will need a small table for each the WHtR station or one placed between two stations. It is important to be sensitive to the athlete’s privacy. Have a small room divider or pipe and drape area setup next to the scale and stadiometer area to offer privacy is recommended. Athletes can leave shoes and other belongings in the screening waiting area while this measurement is taken.

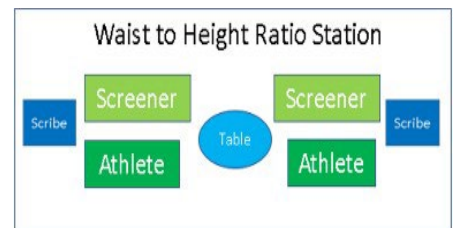

How to Measure WHtR To prepare for individual measurements, always be sensitive to the athlete’s privacy. Refer to [“Height Measurement Poster”](#) in the appendix to remind volunteers of protocol.

Record the measurement on the form/tablet without commenting out loud or calling attention to negative results.

Step 1: Ask athlete to raise clothing so tape measure rests against bare skin.

Step 2: Find the waist. With your fingertips, find the top of the athlete’s hips and measure their waist there, usually just a little bit above the belly button.

Step 3: Place the measuring tape around the middle just above the hipbone.

Step 4 : Make sure the tape is horizontal around the waist. Measure the waist just after the athlete breathes out. The tape should be level with the floor, snug and not too tight

Step 5: Measure it a second time to be sure it is accurate and agrees with the first measurement. If not repeat until the two measurements agree.

Step 6: Record to the nearest centimeter or inch and mark accordingly and enter results on tablet or HAS form.

Step 7: The WHtR will be generated by HAS (on tablet, or post event if measurements recorded on the HAS form.

Step 8: The WHtR will be calculated, and referrals made at the Check-Out station.

Taking Waist Circumference

Materials



Flexible tape measure

- 

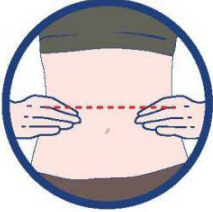
1 **Remove or raise clothing** so tape measure rests against bare skin.
- 

2 **Find the waist.** With your fingers, find the top of the hips and measure the waist there, usually a little bit above your belly button.
- 

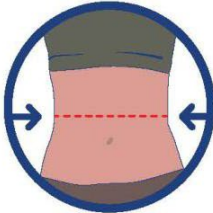
3 **Place the measuring tape around the middle,** just above the hipbones.
- 

4 **Make sure the tape is horizontal** around the waist. Measure your waist just after the athlete breathes out.

The tape should be:

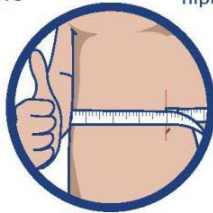
 - level with the floor
 - snug
 - not too tight
- 

5 **Measure it a second time** to make sure it is accurate.

 - Enter **waist size** in centimeters or inches. (round to the nearest number)

Correct tape placement

Incorrect tape placement

WHtR Station Actions and Referral

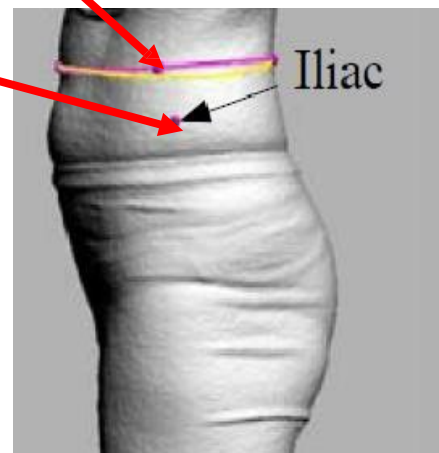

The WHtR results will be calculated and discussed at Check-Out. The Healthy Athletes Software will also calculate WHtR using data entered in HAS. The chart illustrates the WHtR value, classification and required referral actions. Results will be discussed with the athlete at Check-Out.

Waist-to-Height Ratio Chart Males and Females ≥ age 5

WHtR Value	Classification	Action
.4 or less	Slender	Referral
.4 -.5	Healthy	
.5 - .6	High central fat	Referral
≥.6	Very high central fat	Referral

Waist Height Ratio Challenges

Possible causes of waist measurement error:

- Can be difficult to find the correct anatomical site for measurement, especially in obese individuals.
- Athlete uncomfortable and moving.
- Wrapping the measuring tape too tightly or too loosely can result in a false estimate.

Issue	Correction	
Athlete not comfortable	<ul style="list-style-type: none"> • Make sure you are slowly and clearly explaining the process • Ask a volunteer to go through the process or have them watch another athlete get screened to see the procedure. • If the above does not work, the athlete can just move on to the next station. Don't pressure an athlete to do a screening they are uncomfortable with. 	
Screeener technique variability	<ul style="list-style-type: none"> • Ensure two individuals involved in each measurement 	
Station Set up	<ul style="list-style-type: none"> • Close to stadiometer & scale • Small table with 2-4 tape measures • If available, a flexible tape-measure with instruction card may be given to athlete so they can continue to monitor waist at home 	
Quality Assurance	<ul style="list-style-type: none"> • Set a regularly scheduled time for quality assurance observation of measurements • Check all equipment before the training session begins • Establish measurement teams of two individuals, where each team completes a waist circumference measurement on two athlete and compare results • Each team calculates the WHtR and compare results 	

CHAPTER 3 WHtR Training Skills Record

Date _____
 HPCD _____

Location _____
 Trainee _____

When training, use this table to document volunteers' WHtR screening, referral and brief education skills. Volunteers should be measure each other's waist and height, and record both for each volunteer. Regroup and share results. If there are different measurements for the same person. Determine cause of discrepancy.

Training Skills Activity: Waist Height Ratio

Volunteer Objectives Volunteers will be able to:

- 1) Explain the screening purpose and process as would be done with athletes.
- 2) Follow instructions to correctly measure the waist and height for at least 3 fellow volunteers, in metric and English units).
- 3) Compare measurements with fellow volunteers.
- 4) If results are different, account for the discrepancy.
- 5) Calculate WHtR with calculator.
- 6) Correctly record results on the sample HAS form.
- 7) Provide appropriate referrals based on WHtR result, as would be done at Check-Out.

Materials

1. Flexible tape measure with metric and English measurement units on either side.
2. *Screening Reference Guide-Waist Height Ratio*
3. HAS for or Tablet
4. WHtR Poster for Correct Tape Measure Placement

Method or Activity Waist Height Ratio Checklist Instructions

Observe volunteers as they do waist and height screening for 3 fellow volunteers. Observe interaction of measurement being completed with one or more athletes. Use this form to provide feedback for trainees regarding correct WHtR screening procedure.

Waist Height Ratio Station- WHtR				
Number of Volunteers: 2 per station. One clinical volunteer to measure, one general volunteer to record result.				
Activity	Yes	No	NA	Comments
Volunteer explains to athlete s/he will be measuring their waist and shows a picture to illustrate the procedure.				
Volunteer asks athlete if s/he has questions and if it is ok to measure their waist.				
A flexible tape measure is used for the measurement.				
Athletes are measured with top clothing raised above waist; tape is horizontal, snug but not too tight. Follow steps shown on the WHtR Measurement Guide .				
Record measurement to the nearest inch or centimeter.				
WHtR training checklist				
Activity	YES	NO	N/A	COMMENTS
• Measuring tape is correctly placed around athlete's waist.				
• WHtR is calculate and recorded correctly. (Results will be explained at Check-Out Station.)				

CHAPTER 3

Waist Height Ratio

APPENDIX

1. Background Discussion
2. [Waist Height Measurement Poster](#)
3. [Screening Reference Guide- Waist Height Ratio](#)
4. Frequently Asked Questions- Waist Height Ratio
5. References

Chapter 3 WHtR Appendix 1 Background

Background Information

the formula used **To calculate the waist height ratio or WHtR** is waist circumference / body height. Divide waist (in inches) by the height (in inches).

The health waist size compared to a person's height is half the height. For example, a person who is 5 foot 5 inches, (65 inches or 167.64 centimeters) should maintain a waistline smaller than 33 inches or 84 centimeters.

Using a simple, rapid screening tool-the waist-to-height ratio could help overcome debate about the use of different BMI boundary values to assess health risks in different populations. There are six reasons supporting use of WHtR

1. It is more sensitive than BMI as an early warning of health risks.
2. WHtR is less expensive and easier to measure and calculate than BMI.
3. A boundary value of WHtR = 0.5 indicates increased risk for men and women, for people in different ethnic groups, regardless of age.
4. WHtR boundary values can be converted into a consumer-friendly chart as shown below.
5. Communicating messages about health risk could be much simpler if the same anthropometric index and the same public health message is used throughout childhood, into adult life, and throughout the world. This simple message is "Keep your waist circumference to less than half your height".

How many inches is a normal waist? For your best health, your waist size should be no more than half of your height. If it is larger than that, you may want to talk with your doctor or dietitian about what your next steps are, including losing weight. You cannot spot-reduce your waist, or any other part of your body.

Waist-to-Height Ratio Chart **Males and Females ≥ age 5**

WHtR Value	Classification	Action
.4 or less	Slender	Referral
.4 -.5	Healthy	
.5 -.6	High central fat	Referral
≥.6	Very high central fat	Referral

Why is waist size important? Measuring the waist is a good way to know if an individual is carrying too much fat around the middle, which can raise risk of heart disease, type 2 diabetes, cancer, stroke, liver disease and sleep disorders. A person can have a healthy BMI and still have too much abdominal fat, meaning they are still at risk of developing these diseases.

How can an individual lose inches off the waist? Adjusting dietary intake, and physical activity can result in overall weight loss including abdominal fat. The recommended dietary pattern includes high-protein foods, such as eggs, fish, seafood, legumes, nuts, meat and dairy products and limits simple carbohydrates including added sugars and refined grains, adds fiber-rich foods and minimizes alcohol consumption. Source: NCBI Waist Circumference study.

Some aerobic exercises to tone the abdomen include:

- Walking at a quick pace
- Running
- Biking and cycling
- Labor
- Rowing
- Climbing
- Dancing
- Swimming
- Group fitness classes

Why is WHtR different than BMI? WHtR is the waist circumference divided by height and is an anthropometric index for measuring central adiposity. WHtR is a more sensitive universal screening tool than BMI to detect health risks, less expensive to monitor and easier to do. A WHtR cutoff of 0.5 can be used in both genders, all ethnic groups and that the same cutoff can be applied in children and adults

Risk of Weight around the Waist Visceral fat, or body fat stored within the abdominal cavity and around internal organs such as the liver, pancreas, and intestines, increases risks of non-communicable diseases including heart disease, type 2 diabetes, cancer, stroke, liver disease and sleep disorders. Fat within the abdominal cavity also provokes inflammation, which leads to additional health problems and makes it even more problematic.

Does the WHtR work for children? The WHtR calculation is equally valid for children ≤ 5 as it is for adults. WHtR is considered a valuable screening tool, particularly for children as young as 5, who are showing initial signs of excess weight gain, or whose lifestyle or heritage puts them at greater risk of obesity

Healthy Weight to Height Ratio- To measure WHtR, record waist circumference then divide that number by height.

- **WHtR > 0.5** Higher risk of diabetes, heart disease, stroke, and lower life span
- **WHtR < 0.5** Considered healthy for both men and women, ages 5 and older, worldwide

BMI Shortcomings BMI is measured by a person's weight in kilograms divided by the square of their height in meters, a complicated calculation and the formula is unfamiliar to most people. BMI doesn't make allowances for the distribution of fat around the body.

Visceral Fat Recently British scientists documented that a typical 'apple' shaped person, who carries excess abdominal fat (which sits close to the heart, liver and kidneys) is at greater health risk than a pear-shaped person, who typically carries weight on the hips, thighs and bottom.

Measuring waist is fundamental because it accounts for critical levels of fat that accumulate in between internal organs and the torso, aka visceral fat or 'central obesity'. It has been demonstrated that people with the highest WHtRs (whose waistlines measured 80% that of their height), lived on average 17 years less than their lower WHtR counterparts. For a 6 ft man (72 inches), waistline should be 36 inches or less. A 5 ft 4in (64 inch) woman's waist should measure 32in or less. For people under the age of 40, a WHtR of over 0.50 is considered to put them at critical risk. For the over fifties, the critical values start at 0.60.

Taking Waist Circumference

Materials



Flexible tape measure



1 Remove or raise clothing so tape measure rests against bare skin.

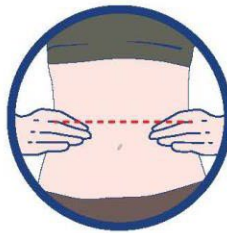

2 Find the waist. With your fingers, find the top of the hips and measure the waist there, usually a little bit above your belly button.



3 Place the measuring tape around the middle, just above the hipbones.

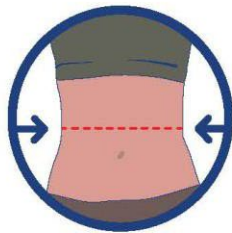

4 Make sure the tape is horizontal around the waist. Measure your waist just after the athlete breathes out.

The tape should be:

- level with the floor
- snug
- not too tight

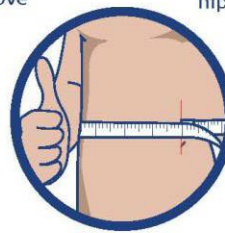

5 Measure it a second time to make sure it is accurate.

- Enter waist size in centimeters or inches. (round to the nearest number)

Correct tape placement



Incorrect tape placement

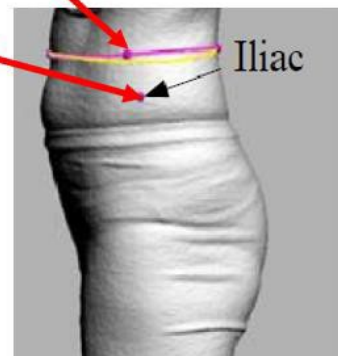

Chapter 3 WHtR Appendix 4 [Frequently Asked Questions](#)

What is Waist to Height Ratio?	The waist to height ratio (WHtR) is the waist circumference divided by your height.
What does WHtR tell us?	As the WHtR ratio rises above .5 it is associated with a progressively higher risk of chronic disease including metabolic syndrome, cardiovascular disease, type2 diabetes, hypertension, stroke, atherosclerosis, non-alcoholic fatty liver disease, sleep apnea and some cancers
Is WHtR different for children and teens?	No, the measurement and ratio are the same for all ages two and older
What is it a healthy WHtR?	A healthy waist to height ratio is less than .5. Your waist should be less than half your height.
How many inches is a normal waist?	For your best health, your waist size should be no more than half of your height. If it's larger than that, you may want to talk with your doctor or dietitian about what your next steps are, including losing weight. You can't spot-reduce your waist, or any other part of your body
What is visceral fat?	Visceral fat is a type of fat that produces hormones that cause inflammation. It is stored in the abdominal cavity and around organs like the liver, pancreas, heart and intestines. The higher the WHtR, the more visceral fat a person has, and the higher risk they are for metabolic syndrome, cardiovascular disease, type2 diabetes, hypertension, stroke, atherosclerosis, non-alcoholic fatty liver disease, sleep apnea and some cancers
How is WHtR different than body mass index or BMI?	BMI categorizes a person as <i>underweight</i> , <i>normal weight</i> , <i>overweight</i> , or <i>obese</i> based on tissue mass (muscle, fat, and bone) and height. It has applications for surveillance of population weight trends and not intended to be strictly accurate or reliable for every situation. A person can have a high BMI, but WHtR lower than .5 and be fit and healthy. A person may have a normal BMI, but a WHtR above .5 and be at higher risk for chronic diseases. Both have an important use in monitoring health.
Can I lose inches off my waist through exercise?	All kinds of physical activities are important for health including aerobic, strength training and endurance activities. Suggested activities to reduce belly fat include walking at a quick pace, running, biking, rowing, swimming, cycling, dancing, group fitness, climbing and high-intensity interval training or HIIT that incorporate short bursts of intense exercise mixed in.
Can I lose inches off my waist by changing what I eat?	Nutrition, certain dietary patterns and food and beverage choices play a major role in managing visceral fat. Add more high-protein foods like as eggs, fish, seafood, legumes, nuts, lean meat, low or no-fat milk and dairy foods into your diet. Add fiber-rich foods like whole grains, oats, barley, quinoa, fruit and vegetables. Reduce intake of added sugars, refined grain products and minimize alcohol intake.
Why is WHtR different than just a waist measurement?	Comparing waist size with height is more accurate than a simple waist measurement, because it equalizes interpretation for gender, ethnic groups, and age.
Can I find out if my waist size is too large without using a tape measure?	With a piece of string, a person can measure their height, then fold the string in half and check to see whether it fits around their waist

WAIST-TO-HEIGHT RATIO



WHtR for ages 2-8!

YOUR WAIST SHOULD BE LESS THAN HALF OF YOUR HEIGHT!

WHtR is your waist size in inches divided by your height in inches

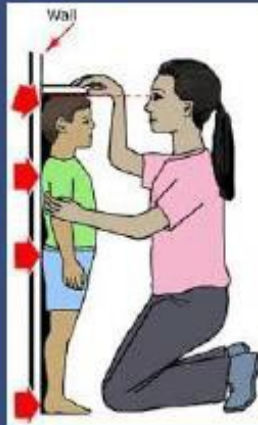

DID YOU KNOW?

- Too many simple carbohydrates and processed foods can cause obesity in children that can lead to Acanthosis nigricans



- This is the formation of brown spots that are typically found on the neck and are a sign of pancreatic visceral fat
- Visceral fat is extra weight around your waist and vital organs that can increase risk of heart disease, diabetes, high cholesterol, certain cancers, and strokes

Lifestyle Changes



It is important to promote healthy habits from a young age to encourage a healthy lifestyle. If your child's WHtR is higher than 0.5, here are some tips to help lower it!

- ♥ **START THE DAY WITH BREAKFAST**
- ♥ **OFFER HEART HEALTHY FOODS**
- ♥ **ENCOURAGE MORE WATER AND SKIM OR LOW FAT MILK**
- ♥ **LIMIT SUGAR INTAKE**
- ♥ **BE ACTIVE WITH YOUR CHILD**
- ♥ **DEVELOP A CONSISTENT SLEEP SCHEDULE**

Screening Reference Guide Waist Height Ratio (WHtR)

Waist Height Ratio is considered to be an excellent tool to better predict cardiovascular risk factors. The WHtR can be used for adults and children. It is a good indicator of central body adiposity. It is not age dependent and can be used across all populations.

Formula for WHtR

Waist measurement divided by height measurement $W \div H$

Waist Height Ratio Station Actions and Referral

The chart below illustrates the WHtR value, classification and required referral actions. The WHtR will be calculated at the Check-Out Station.

Referrals based on WHtR will be discussed at the Check-Out Station.

Waist-to-Height Ratio Chart Males and Females \geq age 5

WHtR Value	Classification	Action
.4 or less	Slender	Referral
.4 -.5	Healthy	
.5 - .6	High central fat	Referral
\geq .6	Very high central fat	Referral

Health Promotion Screening Reference Guide WHtR 2022

APPENDIX 4 Volunteer Training Checklist Waist Height Ratio

Volunteers should review the Waist Height Ratio section of the Manual. After review and discussion, the volunteers should meet the objectives listed below.

Trainee/Volunteer Objectives

Trainees will be able to:

- Correctly place the tape measure around a volunteer's waist.
- Correctly read the waist measurement and record it on the HAS form or tablet.
- Demonstrate ability to capture the previously measured height and record it on the HAS form or tablet.

Objectives for the athlete with regard to Waist Height Ratio

1. Explain, as if to an athlete, why you are measuring the athlete's waist.
2. Explain how WHtR differs from BMI.
3. Explain what the following WHtRs mean.
 - WHtR .5
 - WHtR .6
 - WHtR .4
4. Help athlete gain information on how to have a healthy waist size by
 - Making healthy food and beverage choices, with examples.
 - Engaging in regular physical activity outside of their sports practice, with examples.
 - Getting regular quantity and quality of sleep.

Materials Needed:

A flexible measuring tape that measure up to 70 inches.

Waist Height Ratio poster (see appendix)

Method or Activity Instructions - Blood Pressure Checklist Instructions:

Using the following list, observe trainees/volunteers correctly measure the waist of 3 individuals.

Obtain correct height for the same individuals (at BMI station)

Interact with one or more of these same volunteers and role play delivery of information on

- How to make healthy food and beverage choices-what does that mean?
- Explore activities the volunteer would enjoy, outside of sports practice, that can help them achieve or maintain a healthy WHtR.
- Use observations to provide suggestions to correct WHtR screening procedure if needed.

Date of Observation: _____ Location/Event _____

Name of Trainee _____ Observed by _____

Number of unique role play volunteer interactions observed: _____

In all cases, all results should be confirmed (confirmation values are the same as initial values for purpose of the role play). In cases where the value is high, the appropriate action and referral should be made.

Adult WHtR

1. [Waist-to-height ratio as a screening tool for obesity and cardiometabolic risk](#)
2. [Waist-to-height ratio is more predictive of years of life lost than body mass index](#)
3. [Waist-to-height ratio is a better screening tool than waist circumference and BMI for adult cardiometabolic risk factors: systematic review and meta-analysis](#)
4. [A systematic review of waist-to-height ratio as a screening tool for the prediction of cardiovascular disease and diabetes: 0.5 could be a suitable global boundary value](#)
5. [Waist-to-height ratio as an indicator of 'early health risk': simpler and more predictive than using a 'matrix' based on BMI and waist circumference](#)
6. [A proposal for a primary screening tool: 'Keep your waist circumference to less than half your height'](#)
7. [Waist-height ratio and waist are the best estimators of visceral fat in type 1 diabetes](#)

Pediatric WHtR

1. [Waist-to-height ratio as a risk marker for metabolic syndrome in childhood. A meta-analysis](#)
2. [Waist-to-height ratio is correlated with height in US children and adolescents aged 2-18 years](#)
3. [Waist-to-height ratio as a screening tool for cardiometabolic risk in children and adolescents: a nationwide cross-sectional study in China](#)
4. [Body mass index classification misses to identify children with an elevated WHtR at 5 years.](#)
5. [Waist-to-height ratio index or the prediction of overweight in children](#)
6. [Recent Trends in Waist Circumference and Waist-Height Ratio Among US Children and Adolescents](#)
7. [Screening using Body Mass Index alone may miss every second preschooler with excess abdominal fat](#)
8. [Don't throw the baby out with the bath water](#)
9. [Are there anthropometric and body composition differences between children with autism spectrum disorder and children with typical development?](#)

Bone Density

Athletes age 20 and older **ONLY**



Bone Mineral Density (BMD) Screening Station

Health Promotion conducts Bone Mineral Density screening to calculate the athlete's T-score over 20 years of age. A bone density screening helps identify if the athlete has normal, low or very low bone density (osteopenia) or osteoporosis. The lower the T-score, the greater the risk of non-traumatic fracture. The T-score is used as the basis for education about maintaining and/or improving bone density. It may trigger a referral for additional preventive and medical follow-up and can be used as a baseline.

Background Information

The purpose of including a focus on bone health in is threefold, to:

- Improve the bone health of athletes and help reduce fracture risk.
- Add to the database of information on the bone density status of people with intellectual disability (ID) and
- Document the need to include prevention strategies in health care for people with ID.

People with intellectual disabilities have a higher fracture risk for several reasons including sedentary lifestyle, inadequate dietary intake of key nutrients, low vitamin D levels, aging and hormone deficiency. Certain underlying medical conditions are related to diminished bone health. Some may be prescribed medications that impact bone health. Tobacco use and alcohol abuse further accelerate bone loss at any age, regardless of intellectual disability.

Early identification of low bone density through screening helps establish the need for lifestyle changes and/or medical intervention to improve bone health. Following screening, an athlete's health care provider may order additional diagnostic tests including a 25 D (OH) vitamin D blood test; sequential height measurements; bone density x-ray of the hips and spine, also known as a DEXA (dual energy x-ray absorptiometry), and blood or urine testing, so disease related causes for the bone loss can be ruled out.

Equipment and Tools

Bone Densitometer Specifications:

Several medical devices to screen bone density are approved for use in Health Promotion. These devices are non-invasive, using ultrasound rather than x-ray. The devices can report screening results as a T-score. The test is quick and painless.

Special Olympics Health Promotion has approved the following machines:



See Health Promotion Logistics and Administrative Topics ([Equipment and Supplies List – Chapter 2 Appendix](#)) for information on ordering approved BMD ultrasound devices. Ideally, we recommend that the HPCD and Program staff work with their networks to borrow or rent an approved BMD y device, if local funds or sponsors cannot help purchasing one. BMD screening devices may be borrowed from local medical equipment companies, hospitals, pharmacies or health agencies that offer health fairs. Devices may NOT be purchased with Special Olympics International (SOI) Healthy Athlete capacity grant funding but limited rental costs can be included. Contact the [Health Promotion Discipline Manager](#) to borrow equipment or for help identifying regional outlets for approved devices. For information on the SOI approved bone mineral density devices, contact information for equipment manufacturers, operation manuals found in [Chapter 3 Appendix 1 SOI approved Bone Mineral Density devices, contact information and operation manuals](#)

Additional supplies list: See [Chapter 2 Appendix Health Promotion Equipment and Supplies List](#)

1. Device specific instruction manual
2. Device specific phantom to calibrate equipment
3. Glass of faux milk
4. Vitamin D bottle (empty)
5. Baby-wipes (to clean the device) and Kim wipes (to clean the transducers)
6. Tissues (For athletes to clean their heel after gel)
7. Hand sanitizer and latex free gloves
8. Surge protector, scissors, pens, clipboards, etc.

Suggested Layout

Based on athletes expected, number of volunteers and the event length, your layout may change to accommodate more or fewer bone density machines.

However, at a minimum you will need:

1. Chairs for screener, athlete and scribe.
Assign a general volunteer to record T-score results on the HAS form or tablet.
2. A small table with storage baskets or stacking drawers to organize clinic and office supplies
3. Small trashcans (not 33 gallon)
4. Chairs for athletes to remove shoes and socks and wait if there is a queue
5. A grounded outlet for machines.
6. Signage noting that “Only athletes ages 20 and older need to be screened” must be present. (appendix)
7. Do not offer BMD screening on grass, dirt or in the open sun as it may damage to the device.

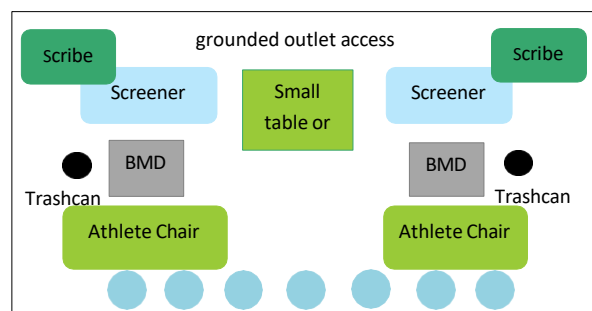

Chairs for athletes to take off/put on shoes and wait

How to Measure – Bone Density using the Sahara

There are three key areas to ensure accurate measurements for athlete screening. These are

1. Athlete and equipment preparation
2. Athlete placement and measurement
3. Reading and recording measurement

Athlete and Equipment Preparation – Bone Density

Greet the athlete and introduce yourself. Confirm the athlete is at least 20 years old. See Chapter 3 appendix for poster, “**Bone density tests for ages 20 and older.**” Explain what will happen and the purpose of the bone density screening. Request that athletes remove shoes and socks.



Before screening athletes ensure the device is calibrated. Follow the ***Sahara Calibration and Quality Assurance Guide*** in Chapter 3 Appendix (or the appropriate calibration instructions for the device being used)

Athlete Placement and Measurement – Bone Density

1. The athlete is seated in an about 12 to 18 inches from the scanner.
2. Place exam paper on the bottom of the scanner foot well.
3. The athlete puts the bare left foot into the foot well. If the athlete’s skin, in the area to be tested, has an open sore, do not measure that heel.
4. Ensure that the middle of the heel is snug against the center of the positioning contour (heel cup) and that the foot is positioned in the well, with the positioning line aligned with the gap between the patient’s second and third toe. The athlete inserts foot into the machine “well” with heel touching the back.
5. Assure the athlete that the test won’t hurt.



Begin screening athletes while following the ***Sahara Measurement Instructions*** found on the [Health Promotion Resources website](#) (or the appropriate measurement instructions for the device being used).

For additional screening tips, refer to the ***Sahara Operation Reminders*** found on the [Health Promotion Resources website](#) (or the appropriate measurement instructions for the device being used).

7. When screening an athlete, test the left heel first, followed by the right heel. Testing both heels is important as our bodies are seldom symmetrical. For example, we wouldn’t test one eye and create a prescription for both eyes. Both T-scores are recorded, and treatment is based on the lower of the two scores. A significant variation in the two heel T-scores is not uncommon due to gait abnormality, a deviation from normal walking or gait. Individuals with gait abnormalities tend to have asymmetrical bone density in their lower body skeleton, from heel to hip. Almost half of Special Olympics athletes exhibit a gait abnormality. Referrals are based on the lowest of the two T-scores.

Read and Record – Bone Density T-score

Recording results on HAS Form or in tablet

The screening result is displayed as a T-score. The results for both the left heel and for the right heel are recorded on the HAS form. Record the complete T-score, including the decimal point and a positive or negative sign.

1. Pay close attention to whether the score is **negative or positive**.
 - Negative scores are shown with a “-” sign in front of the T-score.
 - Positive scores do not show a “+” sign in front of the T-score on the display. However, the “+” **must be recorded** on the HAS form for positive scores.
 - If there a + or – sign is not recorded on the HAS form in front of the T-score, the result cannot be used for referrals, nor entered in the HAS system.
2. If an **asterisk “*”** appears before the T-score, do not record the result as an asterisk means the result may not be reliable. You may try again or screen the second heel. An asterisk will appear
 - if the heel is too narrow or wide, or abnormally shaped, or
 - if not enough gel or coupling material wasn’t applied to the heel
 - if using a Sahara, and you get * for multiple athletes, the device may need to have a quality control (QC) process run. See Chapter 3 Appendix 3.a *Sahara Calibration and Quality Assurance Guide*. If using a different approved device, refer to device manual.
3. If an **error message** appears, follow instructions in the device manual.
4. **Recording:** See Bone Density Screening Procedure Instruction Guide Chapter 3 Appendix

Bone Mineral Density Test (Athletes MUST be at least 20 years old to screen)

T-score → Left heel -0.6 -4.0 to + 5.0

Right heel NA -4.0 to + 5.0

Referral made for BMD follow Up? Yes No

Unable to test

Age under 20

Athlete refused

Athlete unable to cooperate

Unusual heel shape

Bone Mineral Density Test (Athletes MUST be at least 20 years old to screen)

T-score → Left heel -2.1 -4.0 to + 5.0

Right heel +0.2 -4.0 to + 5.0

Referral made for BMD follow Up? Yes No

Unable to test

Age under 20

Athlete refused

Athlete unable to cooperate

Unusual heel shape

The Summary Reference Guide for Bone Mineral Density illustrates the T-score categories and referral guidelines. This is discussed with athletes at the Check-Out station. See [Chapter 3 Appendix 2 Summary Reference Guide-Bone Mineral Density](#)

Screening Reference Guide-Bone Mineral Density

Bone density or bone mineral density is a medical term referring to the amount of matter per cubic centimeter of bones.^{1,2} Bone density or BMD is used in clinical medicine as an indirect indicator of osteoporosis and fracture risk. T-score, the number of standard deviations above or below the mean for a healthy 30-year-old adult of the same sex and ethnicity as the patient. Bone density is a proxy measurement for bone strength, which is the resistance to fracture and the truly significant characteristic. Although the two are usually related, there are some circumstances in which bone density is a poorer indicator of bone strength. In Special Olympics, screening of athletes ages 20 and older is performed on the Quantitative Ultrasound (QUS) device. Athletes with scores of -1.0 or lower, and athletes with scores of +3.5 or higher are referred to discuss the results with their physician. When the T-score for left and right heel vary, the lower number is used for referral.

BMD can be expressed as T-score, which represents a comparison of their bone density with the average bone density of a healthy 30-year-old.	
T-score of -0.9 to +3.4 is considered normal BMD	No referral required
T-score of between -1.0 and -2.4 is considered osteopenia	Referral required
T-score equal to or lower than -2.5 is considered osteoporosis.	Referral required
T-score higher than +3.5 needs a medical referral to rule out lead poisoning.	Referral required

Individual risk factors including any of the following may predispose people with intellectual disability to increased fracture risk. For some, medical intervention may help reduce risk of future fracture.

- The development of less-than-optimal peak bone mass during youth
- Low circulating blood levels of vitamin D
- Inadequate dietary intake of calcium and other nutrients
- Use of anti-seizure medications, anti-psychotic medications, Depo-Provera, corticosteroids, NSAIDs and others.
- Tobacco use and/or alcohol abuse
- Estrogen or testosterone deficiency
- Sedentary lifestyle
- Certain medical conditions, syndromes and heredity

References
 WHO Criteria for Diagnosis of Osteoporosis: <http://www.fbonehealth.org/education/world-health-organization-criteria-diagnosis-osteoporosis/>
 WHO Scientific Group on the Assessment of Osteoporosis at Primary Health Care Level: <https://www.who.int/chi/assess/Osteoporosis.pdf>
 WHO Assessment of Fracture Risk Its Application to Screening: <https://www.who.int/chi/assess/Osteoporosis/2014/>

Bone Mineral Density Challenges

Issue	Correction
Machine not functioning	<ul style="list-style-type: none"> Set bone mineral density machine on a hard surface, not grass or dirt. Make sure the machine is plugged into a grounded wall outlet Run the quality assurance or QA procedure. If this fails, run a full calibration procedure. See Chapter 3 bone mineral density Appendix 3.a <i>Sahara Calibration and Quality Control Guide</i> If an error message appears, follow the troubleshooting steps in manual and/or ask the HPCD to help problem solve.
Athlete not comfortable	<ul style="list-style-type: none"> Have chairs in the area for the athlete to comfortably take shoes off/put on and an area for the athlete to store their personal belongings Briefly explaining the process Ask the athlete to watch another athlete get screened so they can see the procedure Ask the athlete if they are ill, in pain or need to use the restroom. You may want to refer the athlete to medical services if they are ill Athletes are not required to complete a screening they are uncomfortable with. In this case, suggest the athlete move on to the next station
Athlete uses a wheelchair	<p>With the help of a volunteer, rest the machine on the footrest. Guide the athlete to place the left, then right foot into machine foot well and proceed with measurement step. Since non-ambulatory individuals don't benefit from weight bearing activities, they have less bone stimulation and are at higher risk for fracture. Medical intervention, physical therapy, vitamin D and nutrition support can help protect athlete from preventable fractures.</p> 

Unable to test due to heel width or shape	The machine accomdates most foot and heel shapes and sizes. Some athlete may have feet that are very long; or heels that are wider or more narrow than most adults. If an * asterix appears by the T-score, See Chapter 3 bone mineral density Appendix, 3.b Sahara <i>measurement instructions</i> .
--	---

Key Messages for athletes about protecting bone health

Generally, all counseling for the athlete will take place at the check-out station. You may equip your volunteers with some key messages in case they have time to chat with athletes and/or if the athletes ask any questions. These key messages could include:

1. Drink low fat cow's or soymilk daily, instead of sweetened beverages like soda, sports and energy drinks.
2. Don't smoke or chew tobacco.
3. Eat dark green vegetables, fruit and almonds instead of foods with added sugar.
4. Choose plain low-fat yogurt and add your own fruit.
5. Take a calcium pill and a vitamin D pill (ask your doctor about the right dose).
6. Discuss your bone health with your doctor.
7. Ask your doctor about having a vitamin D test.
8. Be physically active.
9. Practice for your sport and do weight bearing and strength building activities 3 or more times a week.

CHAPTER 3

Bone Mineral Density







APPENDIX

1. SOI Approved Bone Mineral Density Equipment
2. Screening Reference Guide – Bone Mineral Density
3. Sahara
 - Calibration and Quality Control Procedures - Sahara
 - Screening instruction Guide – Sahara
 - Frequently Asked Questions – Bone Mineral Density
 - Volunteer Training Tool – Body Mass Index
4. GE Achilles Express
 - Calibration and Quality Control Procedures - Sahara
 - Screening instruction Guide – Sahara
 - Frequently Asked Questions – Bone Mineral Density
 - Volunteer Training Tool – Body Mass Index
5. Osteosys
 - Calibration and Quality Control Procedures - Sahara
 - Screening instruction Guide – Sahara
 - Frequently Asked Questions – Bone Mineral Density
 - Volunteer Training Tool – Body Mass Index
6. References

Achilles Bone Density User Manual

Table of contents and intro	1
Equipment and supplies	2
How the Achilles EXP II works and what the device measures.....	2
Device components and accessories	3
How to clean and disinfect the device	4
How to move the device by its handle	4
How to add water to the device	5
How to inspect membranes for leakage.....	6
How to release air pocket from membranes	6
How to replace the membranes	6
How to drain the water reservoir	7
How to run Quality Assurance	8
How to perform the exam	9
How to understand the results	9
How to replace printer tape	10
Periodic maintenance schedule	10
Common sources of operator error.....	11
Trouble shooting by error message and contact numbers	12
Additional video resources	13



Icon	Function		Icon	Function
	Home page			Maintenance page
	Measurement page			Help page
	Results page			Information on device

The Achilles LCD touch screen guides all Achilles' processes. It's intuitive and easy to follow. Screen prompts use the shown icons to inform operator of process options. Please refer to Achilles Operator's Manual for more detailed information on screen images and flow.

The lock code on the pelican case is 952

Equipment and supplies

Items in Pelican shipping case	Items to be provided by local program
<ul style="list-style-type: none"> • Achilles measurement device • Operator manual • Power cord • Quality assurance phantom • Specialized screwdriver • Spray bottle for alcohol • Water filling bottle • Fill cap to pour water from • Printer tape • Extra membranes • Foot shim for smaller feet 	<ul style="list-style-type: none"> • 70 % isopropyl alcohol • Distilled water • Paper towels • Chairs without wheels • Signage • Small table or stacking drawers • Box of tissue • Garbage can • Surge protector • Microfiber cloth • Heavy duty extension cord • Funnel



How the Achilles measures bone mineral density (BMD)

The Achilles EXPII device is an ultrasonic bone sonometry system. The device converts soundwaves into electrical signals, measures the speed of sound (SOS) and attenuation of the soundwaves (broadband ultrasound attenuation – BUA). It combines the two, to determine the Stiffness Index. See Figure 8.

What the Achilles measures

The Achilles determines broadband ultrasound attenuation (BUA) by measuring the attenuation of ultrasound waves in decibels (dB) at a particular frequency in megahertz (MHz). The typical range of BUA in the normal population ranges from 20-125 dB/MHz. The device also measures speed of sound (SOS) which is used in the quality assurance of the device operation.

The more structurally 'dense' bones are, the more the sound wave will be blocked through the bone. Normal bone results in a higher attenuation, or higher BUA measurement, than osteoporotic bone. Bone which has a high degree of conductivity, such as normal bone, allows for sound waves to move quickly through the bone. Conversely, as bone becomes more osteoporotic or porous, the speed of sound wave will slow down and a lower BUA will be measured.

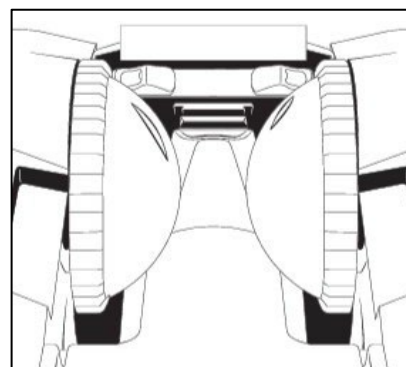
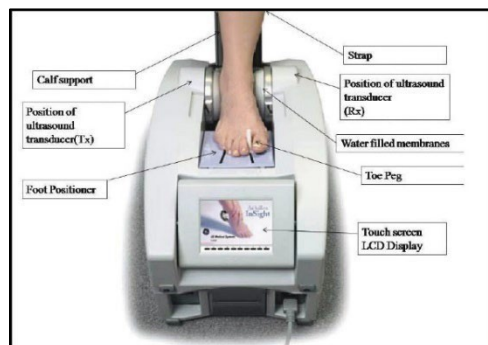

Membranes inflate with warm water. These will gently press against the heel bone and transmit sound waves.

Achilles EXP11 Components

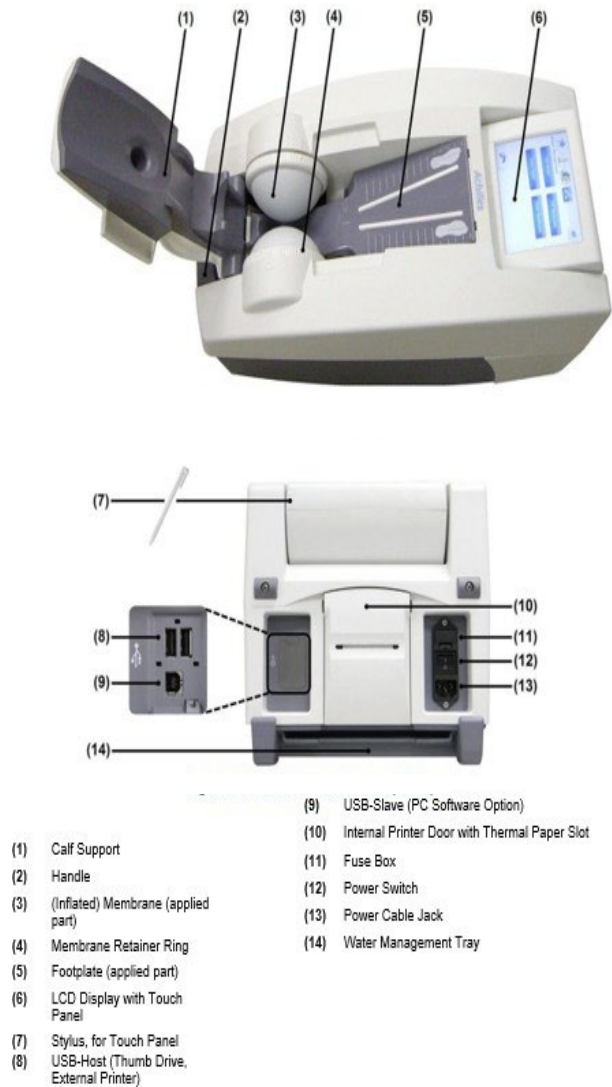

Accessories shipped with the Achilles Device

 Specialized Screwdriver	 Thermal Printer Paper
 Fill Cap	 QA Cylinder
 Alcohol Spray Bottle	 A package of membranes
 Power Cord	 USB Cable
 Distilled Water Pour Bottle	 Document Kit
 Foot Shim (applied part)	 Achilles Manual

The ***Achilles EXP II Operators Manual*** provides detailed instructions on how to operate the device, including screen shots of the **LCD with Touch Panel**.

The menu driven LCD screen guides users through each aspect of device use including installation, device features and accessories, setting up the device for use, performing the exam, troubleshooting and preparing the device for shipping the device. Read this manual thoroughly before operating the Achilles or interpreting results. Keep the Operator Manual with the equipment at all times and periodically review procedures and safety precautions.

Accessories needed for device operation. Each shown accessory will be included with the Achilles device shipped from SOI. All items must be repacked into the Pelican case when returning the device. This will ensure that the next program to use the device will have what is needed to provide the screening service to athletes. Replacement parts can be ordered if necessary.

If one or more of these accessories are misplaced, missing and therefore not included in the return shipment of the device, please inform the Health Promotion by [email](#) and include a signed and dated note explaining the situation in the Pelican case.

How to Clean and Disinfect the System: Low-level disinfection must be performed after each athlete, to help prevent possible cross contamination of infection between people. Only use 70% isopropyl alcohol for cleaning to avoid damage to the device.

Clean Calf Support Remove Calf Support from the device and use the alcohol spray bottle and soft tissue or microfiber to clean the entire Calf Support surface.

Clean Footplate Remove Footplate from the device. Use the isopropyl alcohol spray bottle and soft tissue or microfiber cloth to clean the entire Footplate surface. Let it air- dry. Repeat this step.

Clean Membranes Before you perform measurements each day, inspect the membranes. Use the alcohol spray bottle and soft tissue or microfiber cloth to gently clean the membranes. Sand and grit can puncture the membrane. Be careful not to puncture or tear the membranes when cleaning. Replace the Footplate in the heel well.

Clean Housing Use a micro-fiber cloth dampened with alcohol to gently clean the LCD screen to avoid damaging the screen. Use a soft cloth to clean the surfaces of the housing after you complete other cleaning procedures or whenever necessary.

Drain Water Management Tray Each day, before performing measurements, detach the Water Management Tray and drain any accumulated water. Operators need to check and empty the Water Management Tray periodically during operation to prevent leakage into the measurement area.

Environmental conditions Do not store the device in freezing conditions, as moisture in the device will freeze and damage the device. Operate the device within range of 60-95 Fahrenheit (15-35 Celsius). Operate in a clean, well ventilated environment, free from dust, smoke, and other airborne contaminants. Do not operate outdoors to reduce risk debris and direct sunlight which can damage membranes.



Moving the device by handle. Lift the device gently by Handle. Remove any water in the Water Tray and Footwell before moving it. The water in the reservoir does not need to be removed. Note: water from the reservoir and water tray needs to be removed before shipping.

Add Water Procedure steps 1-6

The water reservoir must be completely full of distilled water before turning the machine on. Do not power up the device without water in the pump. Only use distilled water in the Achilles to avoid mineral damage to the pump.

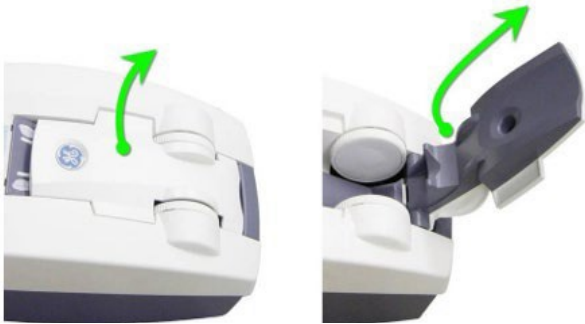

1. Open the calf plate (the hinged lid over the footwell.) Lift and remove the calf-support.



2. Pull from end of Footplate and remove it.



3. Ensure the end of the device is elevated before adding water. Prop up the handle end with Calf Support. If elevated, the reservoir will fill completely.

If the reservoir is low on water, the pump may fail to retract completely due to vacuum pressure inside of the pump and QA will fail.



4. Remove the black fill peg with the specialized screwdriver. Remove at least one membrane. Rotate the membrane ring counterclockwise, remove it and then remove the membrane.



- 5) Remove at least one membrane. Rotate the membrane ring counterclockwise, remove it, and then remove the membrane.
- 6) Add distilled water until the water level reaches the threads of the fill port. Replace black fill peg, membrane and Retainer Ring. Thread correctly to avoid stripping the threads.



7. Replace Fill Plug, Membrane and Retainer Ring. Click continue, and the membranes will inflate.
8. Check membranes for leaks, air bubbles or irregularities.

Inspect Membranes

Are membranes clean and free of dirt or debris? If not, spray with alcohol to rinse off debris. If needed, gently wipe with a microfiber cloth or soft tissue. Avoid use of paper towels on membranes to prevent scratches.

Are membrane surfaces flat without puckering? If membranes are incorrectly situated on have puckers, the device will not pass QA.

Do membranes show a leak when filled with water?

Click Fill Membrane on screen and inspect the filled membranes for leaks.

DO NOT replace the membranes when they are inflated. Click Drain Membranes. If either membrane leaks, replace both and recheck.



A membrane with a leak

Replace Membranes Change the membranes if they begin to leak or if the device prompts you to change them. Replace both membranes at the same time.

- If the membranes are filled with water, click **Drain Membrane** before replacing.
- Remove the Calf Support and the Footplate
- Rotate Membrane Retaining Ring counterclockwise and remove.
- Remove both membranes.
- Dry and clean the area behind the membranes so the new membranes will stick as you attach them.

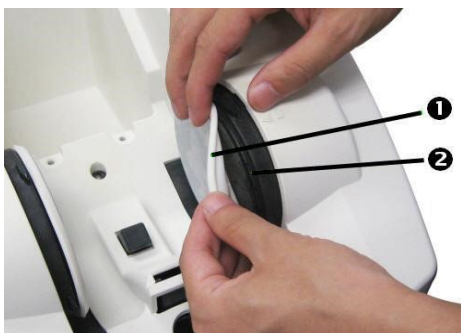

6. **Attach the new membranes.** Make sure that the edges of each membrane are fully attached as shown. The ridge around the edge of the membrane (1) fits into the groove where the membrane will be attached (2).

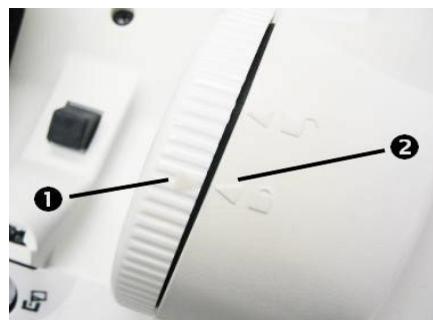

7. **Reattach retaining rings over the membranes.** Ensure the rings are completely rotated clockwise, and the triangle on rings (1) are right against the triangle on the cover (2) as shown. Refill the membranes to check for leaks.

Release Air from the Membranes

As the water in the pump is heated and cooled, it can de-gas (gas that is in solution within the water is liberated) and accumulate in the membranes. This is most likely to happen in the days immediately after a complete fill or complete replacement of the water. Even after a successful Add Water procedure, some air may accumulate in the top of the membranes. If the filled membranes have a large bubble of air at the top, follow these steps to release the excess air.

- 1) Ensure the membranes are deflated.
- 2) Remove the calf-support, footplate, and membrane retaining rings.
- 3) Carefully remove membrane ridge from groove to vent excess air out of the top of the membranes.
- 4) Reattach membranes and membranes retaining rings.

Drain Water Tray Procedure

Follow process if water begins to seep onto floor; before storing device when not in use. Drain System before shipping this product.

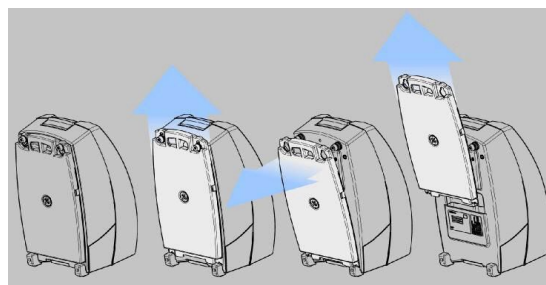
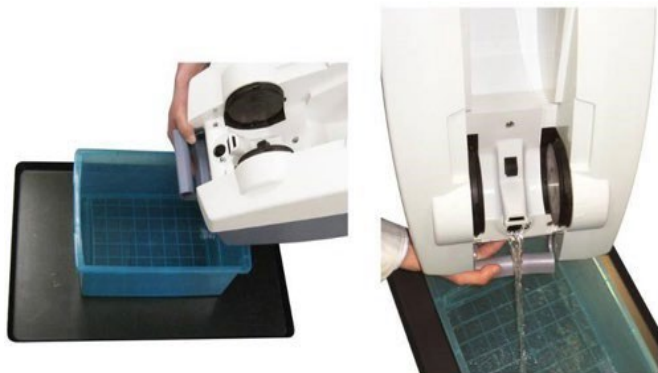

Drain the Device

- Power down and unplug power cable from the device.
- Prepare a container for the water.
- Remove the fill plug.
- Tilt the device on its front (handle) end.
- Shake device gently to ensure all water is drained.

Drain the Water Management Tray

- Power down and unplug the device
- Ensure that fill plug and membranes are attached.
- Stand the unit on its end and slide tray up. Lift it away and off the unit as shown.
- Drain the Water Management Tray into a container by tipping to a corner.



Reattach the Water Management Tray to the unit by seating the lower end into the slots on the rear glides, mounting the foot holes onto the unit's front feet, and then sliding the tray down into place. Reposition the device for measurement.

Perform Quality Assurance (QA) Procedure The water reservoir must be completely full of distilled water before turning the machine on. The Achilles device requires completing QA before first time use, or after device has been turned off. Remove QA Cylinder stored beneath the foot plate. Prepare the Spray Bottle filled with 70% Isopropyl Alcohol.

The QA or the phantom, is stored beneath the foot plate. This protects it from damage and helps ensure that it is available during the screening process.



Spray both membranes and both sides of the QA cylinder generously with alcohol.



Place the QA Cylinder between deflated membranes.

Steps to calibrate device: The Achilles must be calibrated once every 7 days using the QA phantom, and/or when the device is turned off. The device will cue the operator when it is switched on as to the need for QA.

Step 1: Device notifies when QA measurement required. Begin a session by following the on-screen instructions and using the QA phantom and rubbing alcohol. Briefly, the operator will spray both sides of the phantom and both membranes on the device with rubbing alcohol and then select next on the screen.

Step 2: Press “continue” on the screen. The membranes will fill with water and there will be a countdown on the screen. Do not disturb the Achilles device during the QA process.

Step 3: Evaluate QA result. The device will indicate whether or not the QA measurement was successful on the screen and will automatically print the result. In the case of a “fail” result,

- confirm the water reservoir is filled to the top and rerun the phantom
- confirm that there are no leaks in the membranes and that sufficient alcohol was used on the phantom
- check troubleshooting guide for further suggestions

Steps to complete a BMD exam on an individual

Step 1: The individual must be comfortably seated in a stable chair. Ensure the individual can comfortably sit back in the chair with the foot correctly aligned in the Achilles footwell. The leg should rest comfortably on the calf support and the heel placed firmly against the back wall of the footwell. The first two toes straddle the ridge on the footwell of the device.

Step 2: Ask individual to remove shoes and socks from both feet. Avoid testing heels with abrasions, bleeding sores, infection or diseases like eczema and psoriasis on the foot or heel. Test both heels, starting with the left.

Step 3: Determine if foot insert is needed. An anatomical foot insert is supplied to ensure the proper alignment of the foot with the transducers. To determine if the foot insert (foot shim) is needed, ask the individual about shoe size; if they are less than a size 6, then the shim is required. No shim is needed for a foot greater than a size 6. Ask the individual to remove his or her foot from the footwell and place it on top of the device; place the foot shim into the device, if needed.

Step 4: Enter individual-specific data into the Achilles device and begin measurement. Enter gender, age and which foot is being tested into the device. Prompts will appear on the touchscreen for each entry needed. When switching to second heel, press “retest” and specify the new heel (right or left) then proceed with the second test.

Step 5: Apply Isopropyl Alcohol. 70% Isopropyl rubbing alcohol must applied to ensure good contact is made on each side of the heel. Two to three sprays, creating a thin layer of alcohol should be placed on each side of the heel as well as on each membrane of the device. Proceed quickly to the measurement before the alcohol dries.

Step 6: Position heel in footwell. Place the foot into the footwell. Verify the heel is gently but firmly placed against the back of the footwell. Ideally, the heel should be centered between both membranes to ensure an accurate reading. Click continue on the data entry screen.



Position the athlete (side view)

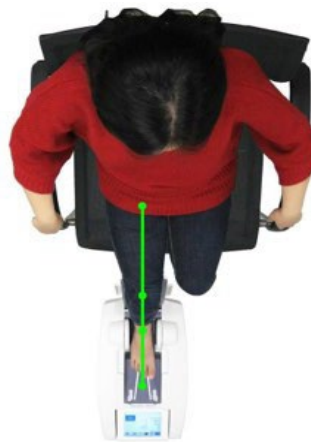

Position the athlete (top)

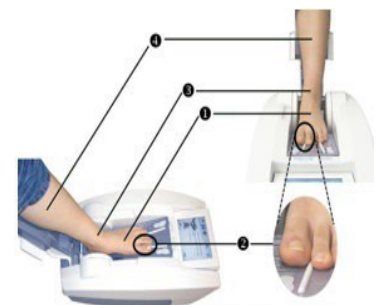
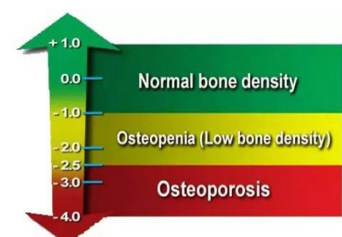

Figure 3-7 Position the foot

Position the foot

Interpret Results Do not share results with as the athlete T-scores are explained at along with bone health counseling and referrals are addressed at Checkout. Interpretation of T-scores follows the World Health Organization definition,

“Osteoporosis is present when BMD is 2.5 standard deviations (SD) or more below the average value for young healthy adult (a T-score of <-2.5 SD). A second, higher threshold describes “low bone mass” or osteopenia as a T-score that lies between -1 and -2.5 SD.”



How to Replace Printer Tape

It is not necessary to print results as T-scores for left and right heels are recorded on the athlete HAS form or entered into a tablet. There may be times when printing results is appropriate. Instructions to replace the thermal printer tape are printed inside the printer cover.

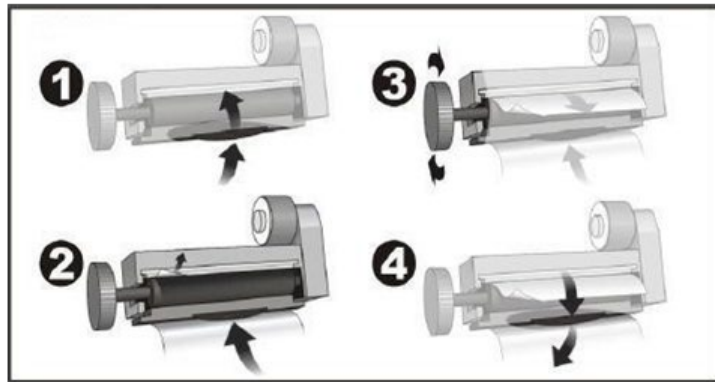

Steps to Replace Printer Tape

- Grasp the top of the printer cover and pull it open
- Lift the Paper Release Lever (❶ in Figure 4-12) and remove the empty paper roll.
- Put the new roll into device (❷) with the lead edge of the paper at the top and facing toward you. The slick side of the paper should be up. The printer will not print if the paper is in backwards.
- Feed the paper into the print mechanism by turning the Paper Advance knob (❸).
- Feed the paper through the slot in the printer cover.
- Lower the Paper Release Lever (❹).

Periodic Maintenance The following preventive maintenance procedures are recommended to maintain proper operation and help prevent possible device service.

Maintenance	Frequency	Notes
Clean and Disinfect System	For individuals: After each athlete For device: as per schedule	See procedure in this section of the manual
Inspect Membrane for a leak, puckering or dirt	Daily	See procedure in this section of the manual
Clean under foot plate	At least daily or after about 50 athletes are screened	Alcohol, water and dirt collect under the foot plate and should be wiped out to prevent overflow into water reservoir
Quality Assurance	Every 7 days and if machine is turned off	System will flag the requirement
Drain and replace the distilled water	After screening for a full day, or after 100 tests	Alcohol or other debris can contaminate water and prevent QA from passing.
Replace Pump Water	When advised by Alpha Source technician. (see page	The pump seldom if ever needs replacement if distilled water is used. However, if you get an error message to replace water pump, contact SOI. Instructions to replace the water pump are included in the replacement kit.

Common Sources of Error when using the Achilles

Equipment

Infrequent use of QA phantom

Equipment not properly maintained (not kept clean, water changed, membrane replaced inspected and replaced as needed)

Failure to use foot shim for athletes with a small foot size

Operator

Not properly trained and mentored

Individual

Athlete was moving or animated during the test

Has thicker heel bones; not uncommon in big-boned people, particularly in men and weightlifters.

Has edema of the feet

Procedural

Improper alignment of the heel

Lack of sufficient alcohol on either the sides of each heel or on the membranes

Failure to test both heels

Membranes are dirty, have a leak, a puckered area and need replacing.

Water reservoir is not fully filled with water because device wasn't correctly elevated when filling.

Ensure water is replaced as recommended to minimize potential mineral or alcohol contamination

Troubleshooting Problems may occur while operating the device that indicates improper action from user, the system status, or errors in the device. Here are some of the general problems and suggestions.

- **The device needs to be within operating temperature and warm enough to pass QA** Please ensure use within the operating temperature and allow a few minutes for the unit to warm up.
- **The device must have proper water level to pass QA** Fill the device by following the **Add Water Procedure**. This ensures the pump is fully retracted.
- **Poor coupling can cause QA failures.** ONLY use 70% isopropyl alcohol or ethanol. Spray both left and right sides of the QA cylinder twice. Spray both membranes twice. Do not allow the alcohol to dry before the QA process begins.
- **Leaking or imbalanced (different size) membranes can cause QA failures.** Leaking membranes lead to low water level which is the primary reason the QA test fails. Imbalanced membranes can cause poor coupling. Replace either leaking or imbalanced membranes.
- **A damaged QA Cylinder can cause QA failures.** Ensure that the thin film inside the QA cylinder is not torn or detached from the cylinder. Also check the QA Cylinder for cracks or sharp edges which can damage the membrane.
- **A dirty transducer surface can cause QA failures.** Remove the membrane rings and membranes. Spray the surface with isopropyl alcohol and wipe the transducer surface with microfiber cloth.



Troubleshooting Guide Based on Error Messages		
Error Msg	Possible Cause	What to Do
More water needed	The water in reservoir is insufficient or the water is not clean.	Perform an Add Water procedure; empty and then refill the device.
System requires Perform QA	QA is overdue. You must perform a QA at least once every seven days and the last QA must have passed.	Perform a QA procedure.
Deflation fail	Screen says, "Air is in the pump".	Perform an Add Water procedure to empty and then refill the device.
Signal too small	The measurement signal was too small to process. This could be caused by incorrect person preparation, positioning, air in the membranes, or the density of the person's heel. The device may need refilling.	Check athlete position. Release air from the membranes. Apply more alcohol to the heel and repeat measurement. Add water to device. If the error appears again, measure the other heel.
Membrane is leaking	A membrane may have been punctured.	Replace the membranes. Make sure you use a lint-free towel or cloth and the alcohol spray to clean the membranes, not a rough material such as paper towel.
Printed tape is blank	The paper roll may have been installed backwards.	Ensure that a paper roll is installed and that it is not in backwards. Make sure the slick side of the paper is up.
Membranes do not inflate	The Membranes may be stuck to the transducer surfaces.	Reinstall the existing membranes. This may free the membranes from the transducer surfaces. You might also need to clean the transducers surfaces.
Discrepancies between the T-scores of the right and left heel are higher than expected.	Accurate measurements require that <ul style="list-style-type: none"> • System is full of good quality Water. • Ample alcohol is applied to both heels. • Ample alcohol is applied to membranes. • Good athlete positioning. • Minimal athlete movement. 	Gait abnormalities are common. If a person favors one side of their body, the skeleton may be denser in that side of the body. This may be due to gait abnormalities, prior injuries, etc. Referral and treatment recommendations are based on the lowest of the two scores.

If Troubleshooting efforts do not fix a problem, contact the [Health Promotion manager](#) for support. You may be referred to the GE technician for further assistance.

Alpha Source contracts with GE to provide technical support to Achilles users. Be prepared before calling, by taking a picture of the machine label with S/N and other pertinent numbers to facilitate help from the technicians. Have Achilles device serial number available before calling for technical assistance.

Alpha Source GE Achilles Contact information	262-307-9000
Alpha Source David Eick- Achilles Engineer	414-760-4051
SOI HP Autumn Jones, Senior Manager	214-629-3836
Mary Pittaway, GCA	406-544-3969

Resources on preparation and use of the Achilles Densitometer

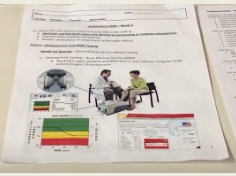
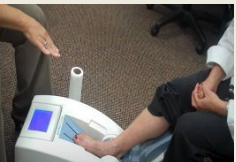
Title and Format	Content description	Where there are minor errors in script, corrections are noted below.	Image
<p>Achilles Operator Manual Included with device in shipping case. Linked here as well for easy printing</p>	<p>Complete instructions on use of Achilles EXP11</p>	<p>Manual recommends only one heel be tested.</p>	
<p>Bone Density Screening using Achilles - How To Set Up Machine 11 minutes YouTube</p>	<p>How to prepare the machine for use: add and drain water, inspect and replace membranes and replace printer paper</p>	<p>Does not show how to prop device with calf rest to ensure filling water reservoir completely.</p>	
<p>Bone Density Screening using Achilles - How To Perform A Screening 2 minutes YouTube</p>	<p>How to seat athlete, prepare heel and membranes with alcohol,</p>	<p>Athletes need to have both heels tested. Gait abnormalities, prior injuries, can cause lower T-scores in one side of the body and not there other. Treatment is based on lowest score. We recommend screener sits across rather than beside the athlete. Use tissue rather than paper towel to wipe heel.</p>	
<p>Bone Density Screening using Achilles - How To Describe Exam and Discuss Results 20 minutes YouTube</p>	<p>How the device measures BMD, what a T-score means, what lifestyle measures can help protect bone and how to share results with the doctor.</p>	<p>T-score is not related to gender. It predicts fracture risk regardless of gender. The lower the score (below zero) the higher the fracture risk. People with IDD generally have low vitamin D levels. We recommend athletes ask their doctor about having their D levels checked and then take the dose of supplemental D needed to maintain a blood level of 40-60 ng/ml.</p>	
<p>Osteoporosis Screening 4 minutes YouTube</p>	<p>Shows an example of a woman having a BMD exam on the Achilles.</p>	<p>Both heels and both membranes must be wet with alcohol before testing. The example shown is for Z- scores which compare the result with a person of like gender and age. We test for T- which predict fracture risk. A 55 year old would also need estrogen or testosterone replacement or medication, plus adequate calcium intake, healthy vitamin D levels of 40-60 ng/mL and exercise to improve their BMD. Most adults need 5000 IU per day.</p>	

CHAPTER 3 (BMI): APPENDIX 1: SOI Approved bone mineral density Equipment

Approved bone mineral density equipment criteria: device is portable, reports results as a T-score and uses non-invasive ultrasound technology (high frequency sound waves, rather than X-ray which uses radiation). Additional machines may be added to the SOI approved list. Contact the [Senior Health Promotion Manager](#) to discuss other options.

 <p>Sahara</p>		 <p>GE Achilles Express</p>		 <p>OsteoSys 3000</p>	
Manual	Sahara manual	OsteoSys 3000 manual	Achilles Express-GE manual		
Contact	<p>Sahara devices are no longer manufactured. They are still used in many countries. Local organizations (e.g., hospitals, professional organizations, pharmacies, medical clinics, medical equipment suppliers and universities).</p> <p>SOI may loan Sahara devices for US programs. To request a loan, complete the request form online.</p>	<p>Available internationally and in the US. Contact local medical equipment supplier for information on loan or purchase.</p> <p>For general information: https://www3.gehealthcare.com/en/nonav-marquee/~media/57f9c197945d4eadb9c29221fc815624.ashx</p> <p>To request a loan, complete the request form online.</p>	<p>Available internationally and in the US. Contact local medical equipment supplier for information on loan or purchase. Local organizations (e.g., hospitals, professional organizations, pharmacies, medical clinics, medical equipment suppliers and universities) may loan or rent Sahara's for use at HP events. Their technicians may volunteer for bone mineral density screening and for the Bone Health education station.</p>		
Estimated cost \$US	Refurbished machines \$1000-\$7000 purchase.	Around \$4,000-6,000	Refurbished machines cost \$5,000 or more.		

Screening Reference Guide-Bone Mineral Density

Bone density or bone mineral density (BMD) is a medical term referring to the amount of matter per cubic centimeter of bones.^[1] BMD is clinical indicator of osteoporosis and fracture risk. A **T-score** is the number of standard deviations above or below the mean for a healthy 30 year old adult of the same gender. BMD is a proxy measurement for bone strength, the resistance to fracture and the truly significant characteristic. Although the two are usually related, there are some circumstances in which bone density is a poorer indicator of bone strength. In Special Olympics, screening athletes ages 20 and older is performed on the Quantitative Ultrasound (QUS) device. Athletes with scores of -1.0 or lower, and athletes with scores of +3.5 or higher are referred to discuss the results with their physician. Our protocol requires screening of both left and right heels. When the T-score for left and right heel vary, the lower number is used for referral.

Bone mineral density can be expressed as T-score, which represents a comparison of their bone density with the average bone density of a healthy 30-year-old. T-score is used to predict fracture risk.	
T-score of -0.9 to +3.4 is considered normal bone mineral density	No referral required
T-score of between -1.0 and -2.4 is considered osteopenia.	Referral required
T-score equal to or lower than -2.5 is considered osteoporosis.	Urgent Referral required
T-score higher than +3.5 needs a medical referral to rule out lead poisoning	Referral required

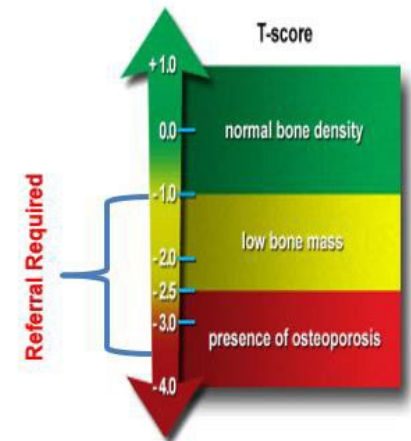







Individual risk factors including any of the following may predispose people with intellectual disability to increased fracture risk. For some, medical intervention may help reduce risk of future fracture.

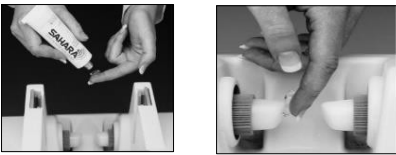

1. The development of less-than-optimal peak bone mass during youth
2. Low circulating blood levels of vitamin D
3. Inadequate dietary intake of calcium and other nutrients
4. Use of anti-seizure medications, anti-psychotic medications, Depo-Provera, corticosteroids, NSAIDs and others.
5. Tobacco use and/or alcohol abuse
6. Estrogen or testosterone deficiency
7. Sedentary lifestyle
8. Certain medical conditions, syndromes and heredity.

References

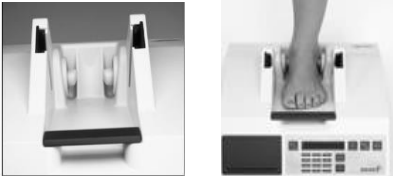
- WHO Criteria for Diagnosis of Osteoporosis <http://www.4bonehealth.org/education/world-health-organization-criteria-diagnosis-osteoporosis/>
 WHO Scientific Group on the Assessment of Osteoporosis at Primary Health Care Level <https://www.who.int/chp/topics/Osteoporosis.pdf>
 WHO Assessment of Fracture Risk and the Application to Screening <https://apps.who.int/iris/handle/10665/39142>

CHAPTER 3 (BMD): APPENDIX 3 Sahara Bone Density Screening Instruction Guide

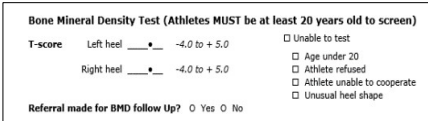
Images	Instructions and Notes
<p>Figure 1. Turn machine on</p> 	<p>Step 1</p> <ul style="list-style-type: none"> • Plug the machine into a grounded outlet. Turn the power on at the black box. A green light will appear. • Press the ON button. The screen will say “Power on Self-Test” “In Progress....” After a few moments the screen will say: “Ready” “Press ON”
<p>Figure 2. Use black “phantom” block.</p>  <p>Store the QC phantom with the unit but not in the heel well. The phantom and pads can be ruined by long term contact with each</p>	<p>Step 2</p> <ul style="list-style-type: none"> • Calibrate the machine following the steps in the Sahara Manual • Clean the machine with <i>Baby Fresh Wipes</i>. Do not use bleach, Clorox wipes, or alcohol pads. • Gel conducts the sound waves when testing. Throughout the testing process, you’ll see a message to “clean pads”. This isn’t necessary and shortens the life of the transducers due to scratches.
<p>Figure 3. Apply adequate gel</p> 	<ul style="list-style-type: none"> • Instead of cleaning gel off the transducers with a wipe or tissue, use your finger to, “scoop” gel that has spread to the outside of the transducer and replace it on the angled tip of the pad. • Apply a pea size amount of gel to the angled tip of each pad using your finger. Don’t touch the metal gel tube on the transducers to prevent damage.
<p>Figure 4. Press “On”</p> 	<p>Step Three:</p> <ul style="list-style-type: none"> • Press the “On” button (See Figure 4) • The screen will say: “Initializing” <p>Describe the screening procedure. Let the athlete know it won’t hurt and why you’re testing. You may ask questions to begin a conversation about bone health like “what sports are you involved in?”, or “what’s your favorite dairy food or beverage?”</p>
<p>Figure 5. Press “open”</p> 	<p>Step 4</p> <ul style="list-style-type: none"> • When the screen says, “See gel pads Press Open” • Press the “Open” button. (See Figure 5) • The transducers will touch each other and then retract • The screen will say, “OpeningInsert foot and press measure” • Do not put the athlete’s foot in the machine quite yet!
<p>Figure 6. Position athletes’ foot</p> 	<p>Step 5</p> <ul style="list-style-type: none"> • When the transducers are retracted (fully open), touch the left knee and ask the athlete to put the left foot in the machine well. • Ensure the athlete’s heel is at the back of the foot well. Rest your hand on top of the athlete’s foot to give reassurance and keep it still. <p>After testing the left heel, and after the machine reinitializes, begin testing the second heel.</p>
<p>Figure 7. Press “Measure”</p> 	<p>Step 6</p> <ul style="list-style-type: none"> • Press “Measure.” (See Figure 3) and the transducers will close on the sides of the athlete’s foot. • The pads emit sound waves through the heel for about 30 seconds. • The machine measures the width of the heel, and the speed of sound waves passing through the heel.

<p>Figure 8. Press “Prep”</p> 	<p>Step 7</p> <ul style="list-style-type: none"> • The transducer pads will open on their own when test is finished. • Ask the athlete to remove their foot when pads are fully open. • Provide a tissue to wipe the gel from their foot while the transducers return and touch during the “resetting” process • You may ask the athlete to rest their foot on the side of the foot carriage in case you need to re-measure if the result has an* beside it • Push “Prep.” (Figure 4) • The machine will process the score and display on the LCD screen.
<p>Figure 9. Record results correctly</p> <p>HAS Form BMD section</p> 	<p>Step 9</p> <ul style="list-style-type: none"> • Since results are recorded on the HAS form, there is no need to print the results for athletes. • Record the score including a “+ or –” before the T-score. • If – or + isn’t recorded, the test result cannot be used for referral and cannot be entered into the HAS system. • When ready, repeat for the right heel
<p>Figure 10. Don’t record results with *</p> 	<p>Step 10</p> <ul style="list-style-type: none"> • If there is an * beside the score, recheck a heel up to 3 times to try to get a score without *. • Do not record results with an * by them, as these scores are invalid. If a * appears each time, thank the athlete for their time, and note on HAS form “unable to test” • The cause may be the heel is too narrow or wide, not enough gel was used on each transducer, or the machine may need QC or recalibration. If an * appears frequently on several athletes, run the QC procedure to help reset the machine. • If an error message appears, refer to the Sahara Instruction Manual.
<p>Figure 11. Athletes who use wheel chairs can and should have BMD test.</p> 	<p>It’s important to test all athletes age 20 or older, especially those with ambulation difficulties. For athletes who use a wheelchair, have a second volunteer help balance the machine on the wheelchair footrest.</p>

When screening an athlete, test the left heel first, followed by the right heel. Testing both heels is particularly important because our bodies are seldom symmetrical. For example, we wouldn’t test one eye and create a prescription for both eyes. Both T-scores are recorded, and treatment is based on the lower of the two scores. A significant variation in the two heel T-scores is not uncommon.

This is an overview of calibration and QC procedures. Refer to the **Sahara Manual** for more detailed instructions.

Calibration

Perform this procedure after the machine is unpacked and before beginning use. Confirm the machine was packed correctly before shipping to your program. If in doubt, take photos of the machine before removing from the box.

Print calibration result to confirm the operability of the machine and save with the machine. This provides proof that it was in good working order before you begin testing giving assurance that all internal systems are operating correctly. The Sahara should be re-calibrated if the QC process fails after 3 attempts.

1. Turn machine on. Wait until it stops “opening and closing” and then
2. Push button that says Program
3. Push 2, push enter, push yes and push yes again
4. Follow the prompts that ask you to type in the numbers on the black “phantom” box. These numbers correlated with the internal test process. Follow the remaining prompts exactly. If you type in the wrong number, or forget a decimal point, you can back space using the – key, but often, you’ll have to start the entire process over so try not to get distracted.
5. Once the prompt reads “Calibration passed” you are ready to begin the testing process.

If the machine or the phantom is not at room temperature, the machine won’t calibrate. The phantom must be the same temperature as the machine. Wait about 60 minutes until the temperature stabilizes. If necessary, use a hair dryer or space heater to warm the area near the machine to speed up the process. If you can get a QC to pass, you can begin screening. The rubber transducer pads may melt if heated by direct sunshine or used/stored in an excessively warm environment.

After using the phantom, replace it in the grey sponge box, zip lock bag or bubble wrap with to protect it. Never store the phantom in the machine reservoir nor where it touches the machine as it will demagnetize.

Quality Control-QC

Perform this process after you do about 75 tests, or if you start getting asterix * beside the T-scores. An asterix indicates that the results are less than 100% accurate

1. Turn machine on. Wait until it stops “opening and closing” and then
2. Push button that says Program
3. Push 1, push enter, push yes, and push yes again
4. When the transducers are retracted, set the phantom in the foot well. Press the measure button and the transducers will close and “measure the phantom”.
5. Follow prompts and if all is well, the prompt will say QC passed.

If all is not well, it will say “QC failed. This means something is not okay with the machine, either temperature is too cold, or the machine is damaged. Refer to the **Sahara Manual** or call Hologic at 1-800-321-4659 for trouble shooting assistance. If you have problems or concerns about calibration or QC procedures, and you are unable to reach Hologic, contact one of the following:

Contact: Mary Pittaway: mpitt59802@aol.com 406-543-8892 or mobile 406-544-3936

CHAPTER 3 BMD APPENDIX 5 Frequently Asked Questions

What is Bone Mineral Density?	Bone Mineral Density or BMD is a measure of bone health, reflecting bone strength as represented by calcium content. A bone density test detects normal bone, osteopenia (or mild bone loss) and osteoporosis, a more advanced degree of bone loss, which may cause symptoms.
What is ultrasound bone density testing?	Ultrasound densitometry uses sound waves to measure BMD at the heel, shin or finger. The device calculates how fast the sound waves pass through the bone. Ultrasound devices are ideal for screening and are radiation-free.
What does a bone density test tell?	The test identifies bone quality, bone loss and determines fracture risk. It measures and compares the density and strength of bones with adults who have healthy bone density.
What is a normal T-score score?	A T-score of -1.0 or higher is considered normal BMD. Between -1.0 and -2.5 is considered low BMD or osteopenia. -2.5 or lower is considered osteoporosis. +3.5 or above may indicate lead presence in children.
What contributes to strong bone density?	Nutrition, lifestyle, environment, vitamin D status, physical activity, hormone status and genetics contribute to bone density. Osteoporosis described as pediatric disease with geriatric consequences. Peak BMD is established by mid-to late-20s. BMD usually decreases with age, so people who don't establish dense strong bones as young adults are at higher risk for low bone density later on.
What foods and beverages support healthy bones?	Calcium sources like milk, cheese, yogurt; fortified milk alternatives and juice; green vegetables like broccoli, cabbage, kale; fortified tofu and soy drinks; sesame seeds and nuts. Vitamin D sources like sardines, anchovies, herring, mackerel, wild salmon. Small amounts found in eggs, meat, fortified cereals and sundried mushrooms. It's not possible to get enough vitamin D from food to maintain healthy levels.
Can I get enough vitamin D from the sun?	Safe sun exposure, depending on time of day, time of year and latitude can provide adequate vitamin D if 2/3 of the body is uncovered. People make different amounts of vitamin D with sun exposure depending on age (as a people age, the amount of direct sun exposure needed to make enough vitamin D increases), the skin color (the darker the skin tone, the amount of direct sun exposure needed to make enough vitamin D increases). UVB rays, which make vitamin D on skin, don't pass through glass, clothing, shade or sunscreen. A vitamin D blood test is the best way to you're getting enough vitamin D from sun, food or supplements.
What else leads to low bone density?	Tobacco, alcohol, aging, low hormone levels, endocrine disorders; low calcium, magnesium and vitamin K intake, inactivity low serum vitamin D levels can cause bone loss. Some medications including drugs to prevent seizures, to treat breast or prostate cancer, anti-depressants, the injectable contraceptive, steroids, antipsychotics and heartburn drugs. Speak with your doctor about how medications you take affect your BMD.
What exercise helps bone density?	Weight-bearing and resistance exercises are the best for your bones. Weight-bearing exercises like power walking, hiking, jogging, climbing stairs, playing tennis, and dancing force you to work against gravity. Resistance exercise like lifting weights, yoga, using exercise tubing or stretch bands help protect BMD.
What is a sign of low bone density?	Usually there are no symptoms in early stages of bone loss. Once bones are weakened from bone loss, signs and symptoms may include back, rib or other bone pain, a loss of height caused by a collapsed vertebra, low trauma fractures and jawbone loss, resulting in gum disease and premature teeth loss
Can a person rebuild bone after bone loss?	Treating osteoporosis means stopping bone loss and rebuilding bone to prevent fractures. Lifestyle changes may not be enough to treat osteoporosis. Some prescription drugs can slow bone loss, and others can help rebuild bone. Adequate calcium, magnesium and vitamin K intake, and healthy serum levels of Vitamin D (40-60 ng/mL) are needed for effective use of prescribed bone repair medications.
Why does Health Promotion offer bone density testing?	People with intellectual disability are at higher risk for low bone density and fractures than the general population. Lifestyle variables that contribute to poor bone health include sedentary lifestyle, low dietary intake of calcium, magnesium, vitamin K and D. Some medications can reduce vitamin D levels and/or accelerate bone break down, hormone deficiency, genetics and some medical conditions contribute.
Can supplements improve bone health?	Calcium and vitamin D are the most important nutrients to bone development. Other nutrients, called co-factors are also needed including protein, vitamins C and K, potassium, magnesium and antioxidants. Calcium citrate is most easily calcium supplement to digest. Multi-vitamins and calcium supplements have small amounts of vitamin D added. Talk to your dietitian or health care provider about the right supplements.

CHAPTER 3 BMD APPENDIX 6: Bone Mineral Density Training Skills Record

Date _____

Location _____

HPCD _____

Trainee _____

When training, use this table to document volunteers' BMD screening, documentation, referral and brief education skills. Volunteers should be in teams or 2-4 measure each other's left and right heels. Have another team re-measure the results should be the same.

Volunteer # 1	Volunteer # 2	Volunteer # 3	Volunteer # 4
BMD left:	BMD left:	BMD left:	BMD left:
BMD right:	BMD right:	BMD right:	BMD right:
Screener:	Screener:	Screener:	Screener:
Scribe:	Scribe:	Scribe:	Scribe:

Training Skills Activity: Bone Mineral Density

Volunteer Objectives

Volunteers will be able to:

- 8) Calibrate the BMD machine(s).
- 9) Perform Quality Control procedure on a BMD machine.
- 10) Explain the screening purpose and process as would be done with athletes.
- 11) Follow instructions to correctly measure the BMD for fellow volunteers
- 12) Correctly record results on left and right heel of fellow volunteers.
- 13) Provide brief bone health education while testing fellow volunteers.
- 14) Provide appropriate referrals based on BMD reading.
- 15) Identify troubleshooting reference in BMD machine operation manual, or online.

Materials

- 5. BMD ultrasound equipment, clinic supplies and BMD section of manual, machine operation manual
- 6. HAS Form
- 7. Screening Reference Guide-Bone Mineral Density
- 8. Bone Health Education Station

Method or Activity Bone Mineral Density Checklist Instructions

Observe volunteers as they do BMD screening for 4 fellow volunteers and/or athletes. Observe interaction with one or more athletes while doing screening. Use this form to provide feedback for trainees regarding correct BMD screening procedure.

BMD Screening Competencies	Volunteer 1	Volunteer 2	Volunteer 3	Volunteer 4
Volunteer to demonstrate ability to do the following:				
Calibrate the BMD machine(s).				
Perform Quality Control-QC procedure on a BMD machine				
Explain the screening purpose and process as would be done with athletes				
Follow instructions to correctly measure the BMD for fellow volunteers				
Correctly record results on HAS form, for left and right heel of fellow volunteers				
Provide brief bone health education while testing fellow volunteers.				
Reiterate suggestions from Bone Health <i>Choose to Change</i> cards				
Identify appropriate referrals based on BMD reading using the Screening Reference Guide-BMD tool.				

In cases where the T-score is below -1.0 or above +3.5, the appropriate action and referral should be made. Ask trainees to identify referral guidance, based on the following results.

Referral?	T-SCORE			
		Left +0.0	Right -1.7	Left -1.0
	Left -2.1	Right -2.1	Left 1.5	Right 1.5
	Left + 3.6	Right +3.0	Left +2.0	Right +1.0
	Left + .9	Right -.9	Left +.5	Right +5
	Left -.9	Right +.9	Left -1.8	Right -.8

1. WHO Criteria for Diagnosis of Osteoporosis <http://www.4bonehealth.org/education/world-health-organization-criteria-diagnosis-osteoporosis/>
2. WHO Scientific Group on the Assessment of Osteoporosis at Primary Health Care Level <https://www.who.int/chp/topics/Osteoporosis.pdf>
3. WHO Assessment of Fracture Risk its Application to Screening <https://apps.who.int/iris/handle/10665/39142>
4. Screening Tests for Adults with Intellectual Disabilities Joanne E. Wilkinson, MD, MSc, Larry Culpepper, MD, MPH and Mary Cerreto, PhD J; Am Board Fam Med July-August 2007 vol. 20 no. 4 399-407. <https://www.ncbi.nlm.nih.gov/pmc/articles/PMC3708482/>
5. Vitamin D Status Around The World: Interactive global map for Vitamin D status. 2015 www.iofbonehealth.org/facts-and-statistics/vitamin-d-studies-map
6. Emphasizing the health benefits of vitamin D for those with neurodevelopmental disorders and intellectual disabilities. <https://www.ncbi.nlm.nih.gov/pubmed/25734565>
7. National Osteoporosis Foundation December 2014: Ask the Expert, “What impact do intellectual and developmental disabilities have on an individual's bone health?” <http://nof.org/files/nof/public/content/file/4309/upload/1051.pdf>



Blood Pressure

Blood Pressure (BP) Screening Station

Background Information

Blood pressure screening is included in Health Promotion for several reasons, such as to

- Identify athletes with abnormal blood pressure readings so action can be taken to prevent adverse medical events before, during and after completion.
- Provide appropriate lifestyle counseling and referrals to improve opportunity for athletes to normalize blood pressure and improve their health.
- Add information relative to blood pressure to the data base on hyper and hypo tension, for this high-risk population.
- Encourage inclusion of preventive health strategies for SOI athletes.

Many individuals are skilled at taking blood pressures. However, Special Olympics Healthy Athletes has established equipment standards and screening procedures to assure that standardized screening, counseling, referrals, and on-site actions for blood pressure screening are followed. It is important that these standards and protocols be shared with the volunteers.

<mailto:healthpromotion@specialolympics.org>

Equipment and Tools

<mailto:healthpromotion@specialolympics.org>

For SOI screenings, digital sphygmomanometers are recommended because they are easy to operate with minimal training and can be used in noisy environments. To assure accuracy of the devices, test the monitors for validity before each event. This procedure is described in the Quality Control Section.

Blood pressure monitor and cuff requirements

- Digital monitors should be used to measure blood pressure on the upper arm. Wrist measurement devices are not approved.
- Monitors should measure in mmHg.
- Blood pressure cuffs come in different sizes. All programs must have three cuffs representing the different sizes, small (pediatric), adult, and extra-large that work with the monitor you have.

BEST PRACTICE: Use manual sphygmomanometer and stethoscope, with necessary cuffs to validate the digital monitors & to confirm low or elevated readings. You'll need volunteers who are able to operate these devices.

Capacity grant funds can be used to purchase the digital and manual equipment for blood pressure and cuffs. SONA programs have access to blood pressure devices through the Henry Schein program. Ask the [Health Promotion Program Manager](#) for information.

Additional Equipment and Supplies

A table, on which to rest the athlete's arm for blood pressure screening and chairs for both the athletes and screeners.

See the [Health Promotion Equipment and Supplies List in Chapter 2](#) for specific information.

Station Layout – Blood Pressure

Based on the number of athletes expected, number of volunteers, and the length of your event, your layout may change. You will need to have a table set-up, chairs for each volunteer and for each athlete. The athlete should be able to rest their arm comfortably on the table.

Have water available for the athletes whose BP is high due to dehydration. Also have screening reference guides for the volunteer's use.

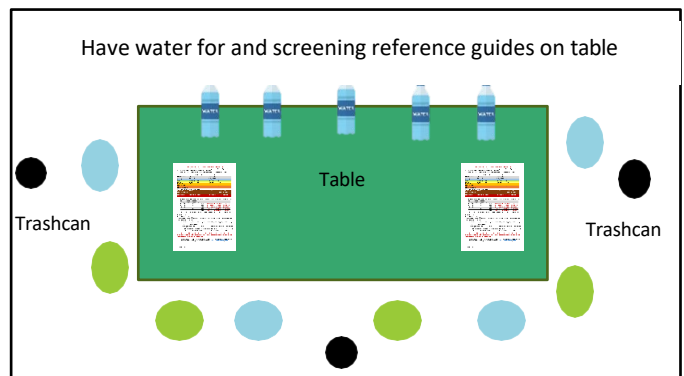

How to Measure - Blood Pressure

Blood pressure is the pressure exerted by circulating blood upon the walls of blood vessels. “Systolic pressure” is the blood pressure when the heart contracts. “Diastolic pressure” is the pressure when the heart relaxes

The three key areas to ensure accurate measurements for athlete screening include:

1. Athlete and equipment preparation
2. Athlete placement and measurement
3. Reading and recording measurement

Athlete and Equipment Preparation – Blood Pressure

To improve accuracy of the reading, athletes should avoid smoking, eating, and physical activity 30 minutes prior to taking a reading. If he or she is showing signs of stress, avoid taking the measurement until the feeling subsides.

To ensure the machines will be accurate, plan to validate the machines against one another, and against a manual blood pressure device to ensure common readings across all machines. Also be sure to check machine batteries and/or power outlets prior to event.

Athlete Placement and Measurement – Blood Pressure

This [poster](#) illustrates the correct athlete placement and measurement technique for blood pressure measurement. It should be visible to all volunteers at the BP station.

Make sure the athlete

- Is seated with their back supported
- Have their arm supported on a tabletop at an even level with their heart.
- Keeps their feet on the floor and to not cross their legs.
- Has the proper cuff size in place.





Use the “[Screening Reference Guide – Blood Pressure](#)” document in the appendix to help train and remind your volunteers of proper placement of athlete for measuring blood pressure. These are the standards to be used at Special Olympics events. We recognize that countries may have slightly different standards in their own practices. The required referral cutoffs should be followed by all.

Measuring Blood Pressure

1. With the athlete correctly positioned, the width of the cuff should cover two-thirds of the upper arm. It should be long enough to encircle the diameter of the arm.
2. Place the tubing at the center of the arm facing forward, and correctly place the sensor. Pull the end of the cuff so that it is wrapped evenly and firmly around the arm. Check that the tightness of the cuff is appropriate. You should be able to just slip two fingertips beneath the cuff, near its edge at the top end. When the cuff inflates it should not cause pain.
3. Explain what will happen next, describe the squeezing sensation the cuff will produce, for how long, and what to do if the athlete wants the screening to stop.
4. Ask the athlete to remain quiet and still during the measurement. Talking with a peer or coach, or even talking on the phone can add 10 points to a blood pressure measurement, rendering it inaccurate.
5. When the athlete seems relaxed and still, press the “start” button.
6. During measurement, remind the athlete to stay quiet and still, and to breathe calmly.
7. The cuff will inflate, then slowly deflate. When the measurement is complete, readings of the systolic and diastolic blood pressures and pulse rate will be displayed on the digital panel.

Read and Record – Blood Pressure

1. Record the reading exactly as displayed on the monitor onto the HAS form or tablet in **mmHg**. Do not round up or down.
2. Refer to the Screening Reference Guide- Blood Pressure reference guide for correct referral action.
3. Make appropriate referral. Depending on the reading, an urgent referral to event medical services may be needed. More information on referrals is located below.
4. Help the athlete reconnect with their belongings and thank the athlete for their cooperation.



Blood Pressure

Right arm 118 / 88
 Left Arm /

Blood Pressure Station Actions and Referral

Blood pressure is the only screening where an urgent onsite referral is required. If the blood pressure reading exceeds 160 systolic and/or exceeds 100 diastolic for adults (or follow the pediatric guidelines for youth under age 13) the following protocol should be followed:

1. Remove cuff from arm.
2. Let the athlete sit for a few minutes, offer water.
3. Hold a light conversation with the athlete, and guide through deep breathing. Say, “let’s try to find out why your blood pressure might be high today.”
 - Do you know if you have high blood pressure? If yes, do you take medicine for your blood pressure? If yes, did you take it today?
 - Have you had any water today? Are you thirsty now?

- Did you smoke or chew tobacco today?
 - Do you need to use the restroom? (if yes, encourage athlete to use toilet, as a full bladder can increase blood pressure)
 - Have you exercised in the last 30 minutes? and
 - How are you feeling today? Probe to find out if anxious, stressed out, feeling ill, or unhappy.
4. Repeat reading with another cuff, if possible.
 5. If still above 160 over 100 (or pediatric cut-off), confirm a third time, using alternate arm with manual kit.
 6. If still above 160 over 100 (or pediatric cut-off), refer to blood pressure reference guide and volunteer should mark urgent referral on HAS form and work with the Clinical Director to refer athlete to medical services for additional intervention.



Volunteers should never indicate that sports participation is in question to the athlete – that should always be handled by event medical services. Find HPCD for assistance. The HPCD will contact medical support and/or escort the athlete to the event medical services

The Screening Reference Guide- Blood Pressure (see appendix) is used to interpret blood pressure readings in Healthy Athletes. It includes information on blood pressure classifications and referral actions.

Key Messages for athletes about preventing hypertension

Generally, all counseling for the athlete will take place at the check-out station. You may want to equip your volunteers with some basic key messages in case they have time to chat with the athletes and/or if the athletes ask any questions. These key messages are included in the Blood Pressure Poster. Available in vertical and horizontal orientation.

Blood Pressure Poster

Referring to the [BP poster](#) (see appendix), share information on any of the following: ways to prevent hypertension, foods that promote healthy BP, how to talk to their doctor about their BP or other topics on the poster.

TIPS FOR HEALTHY BLOOD PRESSURE

TALK TO YOUR DOCTOR ABOUT YOUR BLOOD PRESSURE

- Get regular medical check-ups
- Discuss ways to keep your blood pressure healthy
- Follow your doctor's advice
- Take medicine if your doctor prescribes it

MOVE MORE AND SIT LESS EVERY DAY

- Get 30 minutes of brisk activity most days
- Enjoy sports, dance or yoga classes, biking and walking
- Regular activity helps manage blood pressure, weight and builds strong muscles and bones

KNOW YOUR BLOOD PRESSURE NUMBERS

- Measure your blood pressure often
- 120/80 or lower are healthy numbers
- Track your numbers to see if the changes you've made are working

WHAT YOU EAT CAN MAKE A BIG DIFFERENCE

Choose foods that make you healthy

- Get 5 fruits and veggies daily
- Get 3 servings of low-fat dairy daily
- Eat meat, chicken, fish and beans with no added salt
- Take a vitamin D pill daily

Avoid foods that can increase blood pressure

- Avoid junk and processed foods and fast foods
- Avoid foods and drinks with added sugar
- Avoid salty snacks, cured meats, and salty seasonings

STEPS TO HEALTHY BLOOD PRESSURE

- Get plenty of good sleep
- Be more active
- Maintain a healthy weight
- Follow a healthy meal plan
- Reduce stress
- Take your medicine
- Avoid tobacco and alcohol
- Get regular check-ups
- Track your blood pressure

MANAGE YOUR STRESS

- Make sure to get good, restful sleep
- Avoid tobacco and alcohol
- Practice relaxation
- Learn deep breathing

Blood Pressure Categories:

Category	Normal	At Risk	High
Systolic (top number)	120/80 or less	120-139/80-89	140/90 or more

Blood Pressure Challenges If blood pressure device is not working

Issue	Correction
Display is blank when power is on.	Check and correct the polarity of the installed batteries. Reinstall or replace batteries. Plug into electrical outlet.
Cuff pressure does not increase after pressing “start”.	Check and reconnect cuff attachment and hose.
Measurement incomplete or abnormally low or high values displayed.	Review and follow “Applying Your Blood Pressure Cuff” and “Taking Your Blood Pressure Reading” sections.
Measurements differ from those typically measured by physician or measurement reading’ vary. is different.	Blood pressure readings are influenced by physical and mental conditions and/or even the time of day.
Cuff pressure falls very slowly or not at all. Measurement is not obtainable.	Tubing connector ring may be missing and must be reattached.

Athlete is Uncomfortable with Screening or Appears Stressed

Having one’s arm squeezed can be uncomfortable. Here are tips to put the athlete at ease:

- Smile and assure the athlete that the test won’t hurt and will just take a couple of minutes.
- Slowly and clearly explain the process.
- If necessary, ask a volunteer or another athlete to go through the process and ask athlete to watch.
- Try using a manual blood pressure. You will have more control over the inflation of the cuff.
- Use the right size cuff – if too small it will be too tight, will also impact the reading and be uncomfortable.
- Do not force them to do it. Write “athlete unwilling” on the HAS form and have the athlete move on to the next station.

Blood Pressure Challenges

Blood Pressure machine is not working

Issue	Correction
Display is blank when power is on.	Check and correct the polarity of the installed batteries. Reinstall or replace batteries. Plug into electrical outlet.
Cuff pressure does not increase after pressing “start”.	Check and reconnect cuff attachment and hose.
Measurement incomplete or abnormally low or high values displayed.	Review and follow “Applying Your Blood Pressure Cuff” and “Taking Your Blood Pressure Reading” sections.
Measurements differ from those typically measured by physician or measurement reading’ vary. is different.	Blood pressure readings are influenced by physical and mental conditions and/or even the time of day.
Cuff pressure falls very slowly or not at all. Measurement is not obtainable.	Tubing connector ring may be missing and must be reattached.

Athlete is Uncomfortable with Screening or Appears Stressed

Having one’s arm squeezed can be frightening. Here are a few tips that might put the athlete at ease and feel comfortable:

- Smile and reassure the athlete that the test won’t hurt and will just take a couple of minutes.
- Make sure you explain the process.
- Ask a volunteer to go through the procedure or have the athlete watch a teammate or another athlete get their blood pressure taken first so the athlete can see the procedure.

- Consider doing a manual blood pressure, if the digital machine is what is causing the anxiety – you will have more control over the inflation of the cuff.
- Be sure you are using the right size cuff – one that is too small might be too tight and will also impact the reading and be uncomfortable.
- Have athlete experience the squeezing on their hand
- If the athlete is still uncomfortable with the screening, do not force them to do it. Simply write “athlete unwilling” on the HAS form and have the athlete move on to the next station.

Quality Assurance: Blood Pressure

It is important to assure quality and validity of all Health Promotion screening measurements. There are several considerations to assure quality in blood pressure screening.

- **Validate accuracy of your monitors:** Read the manual carefully before operating the device and follow the manufacturer's instructions. The blood pressure monitor should be validated at each event by testing one individual on each of the appropriate devices. The results should be the same on all devices. The manual sphygmomanometer and stethoscope should be used to confirm the results.
- **Follow the athlete preparation and measurement protocol:** Review the graphic and chart on page 79. Note the impact that crossed legs and an unsupported arm could have on the results.
- **Use the correct size cuff:** A cuff that does not fit (too small or too large) will result in an inaccurate blood pressure reading. The width of the cuff should cover two-thirds of the upper arm. The cuff should be long enough to encircle the whole arm. People with brawnier arm or who are overweight may need bigger cuffs.
- **Accurately record the measurement:** Record the measurement exactly as seen on the monitor. Do not round up or down. Only record mmHG.

CHAPTER 3

BLOOD PRESSURE

APPENDIX

1. Screening Reference Guide – Blood Pressure
2. Frequently Asked Questions – Blood Pressure
3. Volunteer Training Tool – Blood Pressure
4. References – Blood Pressure
5. Blood Pressure Health Education Poster

CHAPTER 3 BP: APPENDIX 1 Screening Reference Guide

Screening Reference Guide - Blood Pressure (Adult and Pediatric) Use this chart to determine what the blood pressure readings mean. This is a screening and not intended to be a diagnosis for high blood pressure as we are only doing one reading. **NOTE:** BP reading is considered abnormal if either value (systolic or diastolic) is outside the normal range.

BP Reading Category	Systolic mmHg -top number		Diastolic mmHg	Action
Hypotensive	Less than 90	and	Less Than 60	Referral
Normal	Less Than 120	and	Less Than 80	none
Elevated	120-129	and	Less Than 80	Referral
High Blood Pressure Hypertension Stage 1	130-139	or	80-89	Referral
High Blood Pressure Hypertension Stage 2 a	140-159	or	90-99	Referral

High Blood Pressure Hypertension Stage 2-b	160-180	or	100-120	Immediate (Urgent) Referral to Event on- site Medical Services
Hypertensive Crisis	Higher Than 180	and/or	≤ 120	Immediate (Urgent) referral to Event On-site Medical Services

Age	Blood Pressure Values*			
	Systolic mm Hg	Diastolic mm Hg		
8	107	69	Referral	<i>122/84 or above → Urgent Referral to Medical Services</i>
9	107	70	Referral	<i>124/86 or above → Urgent Referral to Medical Services</i>
10	108	72	Referral	<i>124/87 or above → Urgent Referral to Medical Services</i>
11	110	74	Referral	<i>126/88 or above → Urgent Referral to Medical Services</i>
12	113	75	Referral	<i>128/90 or above → Urgent Referral to Medical Services</i>

*Any BP reading repeatedly at or above the systolic or diastolic values listed in table 2 requires further evaluation.

On-Site Follow Up to Blood Pressure Results

1. Test BP in right arm. If the right side is in normal range – you are done. No need to test left arm
2. If the right side is abnormal, do the left arm. If the left confirms the right (either hypertensive or hypotensive), then you are done (*and referral is needed*).
 - a. If the left is normal, but the right is not, then let the athlete rest, drink water, and redo the right. If right is now normal too, then the athlete is normal. If the right is persistently abnormal, then the right-side rules the diagnosis (*and referral is needed*)
 - b. In the rare case that the left is more abnormal than the right, the most abnormal reading wins (*and referral is needed*), but we recommend you let the athlete rest, drink water, and reconfirm.
 - c. If the right is more than 20 mm/hg greater than the left, not only is the athlete hypertensive, but they should be referred for a medical evaluation to rule out possible coarctation of the aorta (*referral required*)

Urgent Referral: Per SOI Policy, if the athlete is competing and in Hypertension 2b or Hypertensive Crisis for repeated readings, you are required to notify the coach and send the athlete to the medical event staff for immediate medical clearance prior to competition. The supervising HPCD will facilitate this process.

References:

1. Report of the American College of Cardiology/American Heart Association Task Force on Clinical Practice Guidelines, the 2017 Guideline for the Prevention, Detection, Evaluation and Management of High Blood Pressure in Adults. November 2017. <http://hyper.ahajournals.org/content/guidelines2017>
2. Flynn JT, Kaelber DC, Baker-Smith CM, et al. Clinical Practice Guideline for Screening and Management of High Blood Pressure in Children and Adolescents. Pediatrics. 2017;140(3):e20171904 (not available for free download)

CHAPTER 3 BP APPENDIX 3: Positioning Poster for Blood Pressure Screening

Positioning Athlete for Blood Pressure Screening. [Print poster](#) in color, laminate and post for each volunteer at the Blood Pressure station.

6 SIMPLE STEPS TO GET AN ACCURATE BLOOD PRESSURE READING

The common positioning errors can result in inaccurate blood pressure measurement. Figures shown are estimates of how improper positioning can potentially impact blood pressure readings.

Sources:
Pickering, et al. Recommendations for Blood pressure Measurement in Humans and Experimental Animals Part 1. Blood Pressure Measurement in Humans. *Circulation*, 2005; 111: 697-716.
Handler, J. The importance of accurate blood pressure measurement. *The Permanente Journal/Summer 2009/Volume 13 No. 351*

This graphic was modified from materials from American Medical Association and The John Hopkins University. The original content can be found at <https://www.ama-assn.org/ama-johns-hopkins-blood-pressure-resources>.

Special Olympics
Health Promotion

Frequently Asked Questions-Blood Pressure

High blood pressure is preventable and treatable.	Controlling high blood pressure through lifestyle modifications and taking prescribed medications is the main way to prevent heart attack and stroke. Early detection is key; all adults should know their blood pressure. To lower the risk of high blood pressure, maintain healthy weight, reduce salt and added sugar; eat a balanced diet; keep vitamin D levels normal (40-60 ng/ml), minimize alcohol use; get regular exercise, avoid tobacco and secondhand smoke and get adequate sleep. For many, these lifestyle practices will control blood pressure.
What causes high blood pressure?	While the cause of high blood pressure in most people is complicated, inactivity, poor diet, obesity, older age, and genetics -- can all contribute to the development of hypertension.
What is systolic and diastolic blood pressure?	Blood pressure is measured in millimeters of mercury (mmHg). It is written as systolic pressure , the force of the blood against the artery walls as your heart beats, over diastolic pressure , the pressure between heartbeats. For example, a blood pressure reading is written as 120/80 mmHg, or "120 over 80".
What is a normal blood pressure?	Most health authorities classify blood pressure measurements into these categories: <ul style="list-style-type: none"> • Normal blood pressure is less than 120 / 80 mmHg. • Elevated is 120-129/80 mmHg. • Stage 1 Hypertension 130-139/ 80-89 mmHg. • Stage 2 Hypertension 140 or greater or diastolic pressure of 90 or greater.
How do I know if I have high blood pressure?	High blood pressure or hypertension may not show symptoms, so hypertension is usually found during a routine checkup. If blood pressure is very high, you may have headaches, chest pain, difficulty breathing, or poor exercise tolerance.
What is the treatment for high blood pressure?	Treatment usually involves lifestyle changes and often, medication. Lifestyle recommendations for high blood pressure include: healthy weight, no tobacco use, eat a healthy diet, such as the DASH diet - Dietary Approaches to Stop Hypertension (see below), get regular aerobic exercise, limit alcohol use and ask your doctor for help if you have sleep apnea. Maintain healthy vitamin D blood levels of 40-60 ng/ml.
What type of diet should I follow if I have high blood pressure	A healthy diet, such as the DASH diet, can help lower high blood pressure. The meal plan calls for a certain number of daily servings from various food groups, including fruits, vegetables, dairy products and whole grains. The following steps are recommended: <ul style="list-style-type: none"> • Eat more fruits, vegetables, no/low-fat milk and dairy foods, whole grain products, fish, poultry and nuts. • Eat fewer fried foods, ones high in saturated fat and cholesterol <u>and</u>, less red meat. • Eat fewer foods and beverages with added sugar. • Eat more foods that are high in magnesium, potassium, and calcium. • Eat foods with less sodium.
When should I call my doctor about high blood pressure?	If you have high blood pressure, it is important to see your doctor regularly. Speak to your doctor if you don't respond to prescribed treatment and your blood pressure is still high If you have any side effects from the blood pressure medication; if this happens, your doctor may wish to adjust the dosage or put you on another medication.
Are there any drugs that cause high blood pressure?	Some prescription and over-the-counter medicines that you take for another condition may increase blood pressure. Don't stop take any prescribed medication, including high blood pressure drugs, without talking to your doctor.
What are the risk factors for hypertension?	Modifiable risk factors include unhealthy diets (excessive salt consumption, a diet high in saturated fat and trans fats, low intake of fruits and vegetables, low in no or low-fat dairy products), physical inactivity, use of tobacco and/or alcohol, and are overweight or obese. Non-modifiable risk factors include a family history of hypertension, age over 65 years and co-existing diseases such as diabetes or kidney disease
What are common symptoms of hypertension?	Hypertension is a "silent killer" ,and most are unaware of the problem because of no warning signs or symptoms. It's essential that blood pressure is measured regularly. When symptoms occur, they can include early morning headaches, nosebleeds, irregular heart rhythms, vision changes, and buzzing the ears. Severe hypertension can cause fatigue, nausea, vomiting, confusion, anxiety, chest pain, and muscle tremors. The only way to detect hypertension is for a health professional to measure your blood pressure. People can monitor it at home, with automated devices. A health professional will assess your risk of associated conditions.
What else can help control hypertension?	In addition to making the recommended lifestyle changes, follow your doctor's treatment plan, reduce and manage mental stress, regularly check blood pressure and manage other medical conditions.

CHAPTER 3 BP - APPENDIX 4 Volunteer Training Checklist: Blood Pressure

Volunteers should review the Blood Pressure Screening Section of the Manual. After review and discussion, the volunteers should meet the objectives listed below.

Trainee/Volunteer Objectives:

Trainees will be able to:

- Estimate the number of blood pressure stations given the estimated size of the event.
- Validate accuracy of the blood pressure monitors.
- Choose the correct size and of blood pressure cuff.
- Correctly place the blood pressure cuff on athletes' arm.
- Conduct athlete BP screening
- Use proper cut-off values for medical referral and/or suspension of athletic activity.
- Use decision tree for confirming abnormal values. See appendix (or add to this document)?

Objectives for the athlete with regard to Blood Pressure:

5. Safe participation in sports activity based on blood pressure criteria.
6. Screen and document athlete blood pressure
7. Help athletes become aware of their blood pressure and general classification, e.g., high, normal, or low.

Materials Needed:

Blood pressure cuffs in adult, pediatric and extra-large sizes

Method or Activity Instructions - Blood Pressure Checklist Instructions:

Using the following list, observe trainees for at least 15 minutes as they interact with one or more athletes in the Healthy Athletes Health Promotion screening venue. Use observations to provide suggestions to correct BP screening procedure if needed.

Date of Observation: _____ Location/Event _____

Name of Trainee _____ Observed by _____

Number of unique role play – volunteer interactions observed: _____

Use table on next page to track observations. Ask trainees to identify action, based on the following results:

- Age 40 athlete with left BP of 91/51
- Age 20 athlete with left BP of 125/75
- Age 60 athlete with left BP of 135/85
- Age 25 athlete with left BP of 155/95
- Age 65 athlete with left BP of 180/110
- Athlete aged 10 with left BP of 124/87
- Athlete aged 12 with left BP of 128/85

In all cases, all results should be confirmed (confirmation values are the same as initial values for purpose of the role play). In cases where the value is high, the appropriate action and referral should be made.

Blood Pressure Competencies	Role Play code for interaction observed				Observation Comments
	Hypo	Elevated	Stage 1-2a	Stage 2b– Stage 3	
Estimates number of BP stations needed based on event size and hours					300 athletes in 4 hours = 5 stations (Based on 4 minutes per athlete)
Uses correct cuff size					
Aligns cuff with brachial artery					
Athlete seated with back support, feet on floor, legs not crossed					
Performs BP screening					
Identifies < 90/60 as hypotension					
Hydrates hypotensive athletes for retest 1/2 hour later					
Refers persisting hypotension to on-site medical team for sport clearance by informing HPCD Manager of reading.					
Identifies <160/100 as stage II-b hypertension					
Retest stage II-b to confirm values					
Refers stage II-b to on-site medical team for sport clearance					

Blood Pressure Education Poster

TIPS FOR HEALTHY BLOOD PRESSURE

Special Olympics Health — Golisano CDC

TALK TO YOUR DOCTOR ABOUT YOUR BLOOD PRESSURE

- Get regular medical check-ups
- Discuss ways to keep your blood pressure healthy
- Follow your doctor's advice
- Take medicine if your doctor prescribes it

MOVE MORE AND SIT LESS EVERY DAY

- Get 30 minutes of brisk activity most days
- Enjoy sports, dance or yoga classes, biking and walking
- Regular activity helps manage blood pressure, weight and builds strong muscles and bones

KNOW YOUR BLOOD PRESSURE NUMBERS

- Measure your blood pressure often
- 120/80 or lower are healthy numbers
- Track your numbers to see if the changes you've made are working

Normal	At Risk	High
120/80 or less	120-139 80-89	140/90 or more

STEPS TO HEALTHY BLOOD PRESSURE

- Get plenty of sound sleep
- Reduce stress
- Take your medicine
- Be more active
- Avoid tobacco and alcohol
- Maintain a healthy weight
- Follow a healthy meal plan
- Track your blood pressure
- Get regular check-ups

MANAGE YOUR STRESS

- Make sure to get good, restful sleep
- Avoid tobacco and alcohol
- Practice relaxation
- Learn deep breathing

WHAT YOU EAT CAN MAKE A BIG DIFFERENCE

Choose foods that make you healthy

- Get 5 fruits and veggies daily
- Get 3 servings of low-fat dairy daily
- Eat meat, chicken, fish and beans with no added salt
- Take a vitamin D pill daily

Avoid Foods that can increase blood pressure

- Avoid junk and processed foods and fast foods
- Avoid foods and drinks with added sugar
- Avoid salty snacks, cured meats, and salty seasonings

CHAPTER 3 BP APPENDIX 6 References

1. WHO Hypertension guidelines: <https://www.who.int/health-topics/hypertension/>
 Preventing High Blood Pressure: Healthy Living Habits: www.cdc.gov/bloodpressure/healthy_living.htm
 Preventing High Blood Pressure: www.cdc.gov/bloodpressure/about.htm
 Your Guide to Lowering Your Blood Pressure with DASH: www.nhlbi.nih.gov/health/resources/heart/hbp-dash-index.htm
2. Report of the American College of Cardiology/American Heart Association Task Force on Clinical Practice Guidelines, the 2016 Guideline for the Prevention, Detection, Evaluation and Management of High Blood Pressure in Adults. November 2017. <http://hyper.ahajournals.org/content/guidelines2017>
 Flynn JT, Kaelber DC, Baker-Smith CM, et al. Clinical Practice Guideline for Screening and Management of High Blood Pressure in Children and Adolescents. Pediatrics. 2017;140(3):e20171904 (not available for free download).



Health Habits Interview

Health Habits Interview

Background Information

In addition to the health screenings, athletes participate in a health habits interview. Answers to questions are recorded on the Healthy Athletes System (HAS) form, or tablet. The topics include questions about nutrition, physical activity, bone health, hydration, sun safety, tobacco and hand washing. [A copy of the form and interview questions is available in Chapter 4.](#)

Information gathered from the interview is used to:

- Learn about health behaviors that reduce and/or enhance risk of targeted health concerns
- Reinforce athlete behaviors and choices that enhance or maintain health, and
- Help educate athletes and start a conversation about the athlete's behaviors at the education stations and/or at check-out.

Clinical screening measurements and interview responses are summarized using the HAS system with reports available by event, date, and other compilations. These are used for,

- Health Promotion program planning.
- Creation of surveillance reports for athletes identified risks (BMI, waist height ratio, bone density and blood pressure) and self-reported health behaviors.
- Opportunities to analyze co-morbidities within multiple Healthy Athletes disciplines (i.e., vitamin D use and oral health; physical activity and blood pressure).

Volunteers

Clinical volunteers trained and experienced in client/patient interviewing are well suited for this station. Volunteers may appreciate viewing the [Health Promotion Training video](#) prior to the event, which includes techniques and tips for a successful athlete interview experience.



Station Layout – Health Habits Interview

The Health Habits Interview may be offered at:

- **A Standalone Interview Station:** The entire interview is completed before the athlete moves to the education stations.
- **Relevant Education Stations:** The interview questions are asked at the relevant education station (E.g., nutrition questions at the Nutrition station). After the related questions are answered, the volunteer will transition to the key messages delivered at the Station

Decisions about how and where to offer the interview are important. You'll need to consider space, volunteer availability and interviewing skills. For example, if you are short on space or volunteers, you may be unable to do a separate interview station and will need to ask the questions at the education stations. However, if you don't offer all the education stations, the questions for some topic(s) may be missed. If these happens, if you have adequate volunteers the missed questions can be asked at Check-Out. Doing the interview at Check-Out should not cause athletes to become "backed-up".

How to Conduct the Health Habits Interview

1. After the athlete is seated, say: *'Hello John, my name is Mary, and I am interested in talking to you today about some of your health habits, such as what foods and beverages you consume, your physical activity.'*
2. Ask the athlete about their Special Olympics sport and how the event is going for them to show your interest in the athlete and the events they participate in.
3. Open the Health Habits Photo Guide so the pictures face the athlete and questions face the interviewer. Cover questions using the matching photos for prompts and examples to assist athlete's response.



4. Using open-ended questions, follow the interview guide script and sequence on the HAS form.
 - a. Use open-ended, questions, for example "What do you drink when you are thirsty?" rather than, "Do you drink water when you are thirsty?"
 - b. Give the athlete time to understand the question and develop their response.
5. After the interview, thank the athlete for their participation. Explain that topics from the interview will be discussed at the education stations and Check-Out.
6. Point the athlete to the next station.

Tips for Interview Success

- Be a good listener; take your time; let the athlete take their time.
- Ask questions of the athlete as much as possible, even if they are with their coach or parent.
- Maintain good eye contact if the athlete is comfortable.
- Be non-judgmental throughout the discussion.
- Affirm good health habits. "Keep it up: you're doing great." Or "Congratulations, you are working hard to pick healthy foods like fruit and vegetables."
- Ask the athlete if they would like more information about a topic that showed need for improvement.
- Use the Photo Guide to prompt athlete responses.



The [Photo Guide](#) see appendix uses US images. The template is modifiable for programs who want to include culturally relevant images. Access the template at:

http://resources.specialolympics.org/Topics/Healthy_Athletes/Disciplines/Health_Promotion.aspx

Contact the [Health Promotion Program Manager](#) to see if there is already a modified guide for your region or country.

CHAPTER 3

Health Habits Interview

APPENDIX

1. Health Habits Interview Photo Guide - United States Example
2. Modifiable word template for Health Habits Interview Photo Guide – available at on the [Health Promotion Resources website](#) or [click here](#)

The page below with a **U.S. Example** can be updated to reflect typical options for another state, province or region.
Full Photo guide available on the HP resources website: ([DOCX](#) • [PDF](#))





Special Olympics **Health Promotion**

Chapter Four **Healthy Athletes System (HAS)**

Background Information

The Healthy Athletes System (HAS) enables the electronic capture of screening data across the Healthy Athletes disciplines and is the world's largest and highest quality health database on individuals with intellectual disabilities.

Special Olympics is currently in the process of transitioning the data collection process to a new system, but the questions will remain the same regardless of the platform (e.g. paper or tablet). Programs using the tablet version will do direct data entry using a tablet instead of using paper copies. Programs using paper will be able to more easily enter their data into the online system, post-event.

The local Program that you work with will advise you on their process to collect and report the data. This Chapter provides information on the data reported on the HAS form and an example data report.

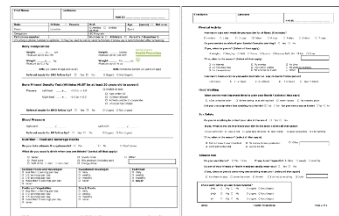

Field	Value
NAME	...
DOB	...
SEX	...
HEIGHT	...
WEIGHT	...
BMI	...
...	...



Latest **Health Promotion HAS Form (modified in 2015)**: Available at:
http://resources.specialolympics.org/Topics/Healthy_Athletes/Healthy_Athletes_Resources.aspx

Completing the HAS Form

Instructions to complete the HAS form are in the Appendix to Chapter 4. Whether you use a paper form or tablet, the form and the information collected is the same.

At Check-In, a volunteer will gather the athlete's general information by asking the athlete or checking their credentials. If possible, ask these questions of the athlete, rather than the coach or parent.

Many Programs choose to have pre-filled out labels that can just be affixed to the form, if using paper. This practice improves accuracy of the data and shortens the checking in process considerably.

After check-in, the athlete will take the HAS form to the first screening station, usually the BMI. If you use the paper HAS form, it travels with the athlete from station to station. If you use tablets to capture the HAS data, the tablets remain at the station rather than traveling with the athlete. Non-clinical volunteers can help with flow management to assist the athletes move from one station to the next to ensure they complete all stations needed.



Instructions for completing the Health Habits Interview is in [Chapter 3- Health Habits Interview](#).

Tips for Completing the HAS Form

- **As recommended earlier, some Programs print labels or** pre-populate these fields before printing the forms for the event to improve accuracy and to save time during the check-in process.
- If handwriting the top portion of the form, write legibly and complete all fields including the location and date of the event.
- Ensure that the athlete's last and first name, gender, birth date and ID number are entered as this is critical for data analysis.
- For Bone Mineral Density screening measure and record the T-score for both the left and right heel and that indicate a + or – before the T-score.
- If a measurement or survey question can't be answered note why not.



Instructions for the electronic tablet process are available on the Special Olympics Healthy Athlete Resources website: <https://resources.specialolympics.org/health/healthy-athletes-system>.

HAS Reports

Following an event, after data entry is complete, Special Olympics will send a Discipline Report to the Program Healthy Athlete Manager, who in turn will share a copy with the Clinical Director.



See [Chapter 4 Appendix 2](#) for a copy of the current (as of April 2020) Health Promotion Discipline Report.

Additional data reports are available as requested by the Healthy Athlete Manager.

Health Promotion Discipline Report on		02/13/2019																									
<table border="1" style="width: 100%;"> <tr><td>Event</td><td>01_Annex_02</td></tr> <tr><td>Number of athletes registered for event</td><td>34</td></tr> <tr><td>Number of athletes attending event</td><td>30</td></tr> <tr><td>Number of athletes screened at Health Promotion</td><td>22</td></tr> <tr><td>% of athletes registered for event screened at health</td><td>64.7%</td></tr> <tr><td>% of athletes who attended event screened at health</td><td>73.3%</td></tr> <tr><td>Age Range</td><td>22 - 33</td></tr> <tr><td>Age Average</td><td>28</td></tr> <tr><td>Sex</td><td>19 (86.4%)</td></tr> <tr><td>Female</td><td>1 (4.5%)</td></tr> <tr><td>Unknown</td><td>2 (9.1%)</td></tr> </table>						Event	01_Annex_02	Number of athletes registered for event	34	Number of athletes attending event	30	Number of athletes screened at Health Promotion	22	% of athletes registered for event screened at health	64.7%	% of athletes who attended event screened at health	73.3%	Age Range	22 - 33	Age Average	28	Sex	19 (86.4%)	Female	1 (4.5%)	Unknown	2 (9.1%)
Event	01_Annex_02																										
Number of athletes registered for event	34																										
Number of athletes attending event	30																										
Number of athletes screened at Health Promotion	22																										
% of athletes registered for event screened at health	64.7%																										
% of athletes who attended event screened at health	73.3%																										
Age Range	22 - 33																										
Age Average	28																										
Sex	19 (86.4%)																										
Female	1 (4.5%)																										
Unknown	2 (9.1%)																										
Blood Pressure Adult		Total	20 - 29	30 - 39	40 - 49	50+	Blood Pressure Youth		8 - 19																		
Hypertensive	0 (0.0%)	0 (0.0%)	0 (0.0%)	0 (0.0%)	0 (0.0%)	0 (0.0%)	Hypertensive	0 (0.0%)																			
Normal	12 (54.5%)	5 (100.0%)	1 (100.0%)	1 (100.0%)	1 (100.0%)	1 (100.0%)	Normal	0 (0.0%)																			
Hypertension Stage 1	2 (9.1%)	0 (0.0%)	0 (0.0%)	0 (0.0%)	0 (0.0%)	0 (0.0%)	Hypertension Stage 1	0 (0.0%)																			
Hypertension Stage 2,3	1 (4.5%)	0 (0.0%)	0 (0.0%)	1 (100.0%)	0 (0.0%)	0 (0.0%)	Hypertension Stage 2,3	0 (0.0%)																			
Total	15	5	1	1	1	1	Total	0																			
Body Mass Index Adult							Body Mass Index Youth																				
Underweight (BMI < 18.5)	0 (0.0%)	0 (0.0%)	0 (0.0%)	0 (0.0%)	0 (0.0%)	0 (0.0%)	Underweight (BMI < 5th Percentile)	0 (0.0%)																			
Healthy weight (BMI 18.5 - 24.9)	1 (4.5%)	0 (0.0%)	0 (0.0%)	0 (0.0%)	0 (0.0%)	1 (100.0%)	Normal (BMI > 5th & < 85th Percentile)	0 (0.0%)																			
Overweight (BMI 25 to 29.9)	1 (4.5%)	1 (100.0%)	0 (0.0%)	0 (0.0%)	0 (0.0%)	0 (0.0%)	Overweight (BMI > 85th Percentile)	0 (0.0%)																			
Obese (BMI 30 and over)	1 (4.5%)	0 (0.0%)	0 (0.0%)	0 (0.0%)	0 (0.0%)	0 (0.0%)	Obese (BMI > 95th Percentile)	0 (0.0%)																			
Total	3	1	0	0	0	1	Total	0																			
Bone Density																											
At risk for Heavy Metal Exposure	0 (0.0%)	0 (0.0%)	0 (0.0%)	0 (0.0%)	0 (0.0%)	0 (0.0%)																					
Normal	0 (0.0%)	0 (0.0%)	0 (0.0%)	0 (0.0%)	0 (0.0%)	0 (0.0%)																					
At risk for Osteoporosis	0 (0.0%)	0 (0.0%)	0 (0.0%)	0 (0.0%)	0 (0.0%)	0 (0.0%)																					
At risk for Osteoporosis	0 (0.0%)	0 (0.0%)	0 (0.0%)	0 (0.0%)	0 (0.0%)	0 (0.0%)																					
Total	0	0	0	0	0	0																					
Tobacco				Active Self-Reported Physical Activity Habits																							
Use tobacco products	0 (0.0%)			Exercise for at least 30 minutes	20 (90.9%)																						
Second hand smoke	0 (0.0%)			6x days	1 (4.5%)																						
				1-5 days	0 (0.0%)																						
				3-6 days	0 (0.0%)																						
				Every day	10 (45.5%)																						
				Permits to take Special Olympics Training (yes)	10 (45.5%)																						
Cardiovascular Plus Factors (Tobacco, BMI, BP, vitamin D supplement)																											
Adult - 2 risk factors	0 (0.0%)																										
Adult - 3 risk factors	0 (0.0%)																										
Adult - 4 risk factors	0 (0.0%)																										
Bone Density	Any tobacco exposure		Calcium consumption (g+)		Vitamin D supplement use																						
At risk for Heavy Metal Exposure	0 (0.0%)	0 (0.0%)	0 (0.0%)	0 (0.0%)	0 (0.0%)																						
Normal	0 (0.0%)	0 (0.0%)	0 (0.0%)	0 (0.0%)	0 (0.0%)																						
At risk for Osteoporosis	0 (0.0%)	0 (0.0%)	0 (0.0%)	0 (0.0%)	0 (0.0%)																						
At risk for Osteoporosis	0 (0.0%)	0 (0.0%)	0 (0.0%)	0 (0.0%)	0 (0.0%)																						
Total	0	0	0	0	0																						

How to Use HAS Reports

A variety of audiences who will be interested in the Health Promotion HAS Summary Report. Within your local program, reports may be used to describe health indices including Body Mass Index, Waist Height Ratio, Bone Mineral Density, and Blood Pressure and athlete responses to the Health Habits Interview questions. The data may be used to establish priorities for athlete education, outreach to the medical and public health community and to recommend Health Promotion topics within health and family education offered by the Program. The reports may also be used to determine who is at risk (by age and/or gender), changes overtime, comparison of data with other programs, regions or global population and for quality assurance monitoring.

The Program or the Clinical Director may present Health Promotion data to potential partners or for fundraising purposes; to demonstrate the value of contributions by existing donors and partners, to attract new donors and partners, to engage in discussions with stakeholders, such as the medical community, policymakers and local governments.



Rarely will an athlete have just one health problem. The Clinical Director may be interested in potential comorbidities of athletes. A special request can be made through the [Health Promotion Manager](#) for reports that look a data across disciplines, for example, obesity, high blood pressure and untreated dental decay. Review the Healthy Athletes forms from other disciplines to see if there are health indices in a specific discipline you may be interested in matching to indices in Health Promotion. Access all Healthy Athlete Software forms here: <https://resources.specialolympics.org/health/healthy-athletes-system>

Each year, Special Olympics issues a [Prevalence Report](#) which provides comprehensive information from all disciplines including screening results, analysis of data and highlights for significant findings.

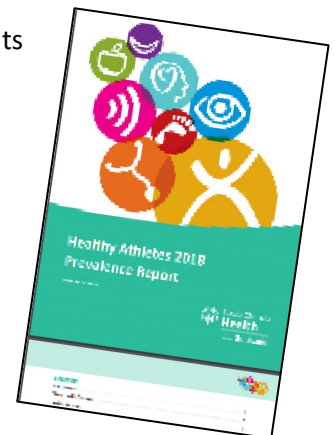

Chapter 4 Appendix

CHAPTER 4 APPENDIX

1. Healthy Athlete System (HAS) Health Promotion Form
2. HAS Summary Report for Health Promotion

Firstname	Lastname	HAS ID _____
------------------	-----------------	---------------------

Date	<input type="radio"/> Male <input type="radio"/> Female	DoB	Age (years) <input type="radio"/> Not sure
Event	Location	<input type="radio"/> Athlete <input type="radio"/> Unified partner	Sport
Delegation		SO Program	
Cell phone number	Number is <input type="radio"/> Athlete's <input type="radio"/> Parent's / Guardian's		

Providing a phone number is optional. It will be used to send a text reminder if any follow up is recommended after screening.

Body Composition

Height _____ • _____ cm
Measure up to 0.1 cm

Height _____ inches
Measure up to 1/8 inch



Weight _____ • _____ kg
Measure up to 0.1 kg

Weight _____ lbs. _____ oz.
Measure up to 1/2 oz.



_____ **BMI** (20 years of age and over)

Waist Circumference _____ cm _____ inches

_____ **BMI** Percentile (under 20 years of age)

WHtR _____

Referral made for BMI follow Up? Yes No **Referral made for WHtR** Yes No

Bone Mineral Density Test (Athletes MUST be at least 20 years old to screen)

T-score Left heel _____ • _____ -4.0 to + 5.0

Unable to test

Right heel _____ • _____ -4.0 to + 5.0

Age under 20

Athlete refused

Athlete unable to cooperate

Unusual heel shape

Referral made for BMD follow Up? Yes No

Blood Pressure

Right arm _____ / _____

Referral made for BP follow Up? Yes No

Left Arm _____ / _____

Nutrition – Food and Beverage Habits

What do you usually drink when you are thirsty? (select all that apply)

- Water
- Fruit juice
- Soft drink Diet non diet
- Other _____
- Sports drink
- Milk product (includes soy)
- Energy drink

<p>Sources of Calcium</p> <p><input type="radio"/> less than 1 serving per day</p> <p><input type="radio"/> 1-2 servings per day</p> <p><input type="radio"/> 3-5 servings per day</p> <p><input type="radio"/> more than 5 servings per day</p> <p><input type="radio"/> never</p>	<p>Sweetened Beverages</p> <p><input type="radio"/> daily</p> <p><input type="radio"/> weekly</p> <p><input type="radio"/> monthly</p> <p><input type="radio"/> never</p>
<p>Fruits and Vegetables</p> <p><input type="radio"/> less than 1 serving per day</p> <p><input type="radio"/> 1-2 servings per day</p> <p><input type="radio"/> 3-5 servings per day</p> <p><input type="radio"/> more than 5 servings per day</p> <p><input type="radio"/> never</p>	<p>Snack Foods</p> <p><input type="radio"/> daily</p> <p><input type="radio"/> weekly</p> <p><input type="radio"/> monthly</p> <p><input type="radio"/> never</p>
<p>Fast food</p> <p><input type="radio"/> daily</p> <p><input type="radio"/> weekly</p> <p><input type="radio"/> monthly</p> <p><input type="radio"/> never</p>	

Firstname	Lastname	HAS ID _____
------------------	-----------------	---------------------

Physical Activity

How many days per week do you exercise for at least 30 minutes?

- No days 1-2 days 3-6 days Every day

Do you exercise outside of your Special Olympics training? Yes No

If yes, what do you do? (select all that apply)

- Weight training Run/Jog Walk Dance Sports Exercise video

Other _____

If No, what is the reason? (select all that apply)

- No interest No money
 Do not know how Physically unable
 No transportation No one to do it with
 No available exercise facility No time

Other _____

How many hours a day do you watch television or play computer/video games?

- 0-2 3-4 5-6 Over 6 hours

Hand Washing

When are the most important times to wash your hands? (select all that apply)

- After using the toilet Other reason
 Before eating or touching food No response/no reasons given

Did you use soap last time you washed your hands?

- Yes No

Do you have soap at your home?

- Yes No

Sun Safety

Do you do anything to protect your skin in the sun?

- Yes No

If yes, what do you do to protect your skin in the sun? (select all that apply)

- use sunscreen wear a hat
 seek shade wear sunglasses
 wear long sleeves I do not do anything

If no, what is the reason? (select all that apply)

- Did not know it was important No money to buy protection
 Do not get sunburned Like to be tan

Other _____

Tobacco Use

Do you use tobacco? Yes No

If yes, how frequently? daily weekly monthly

Do any of your friends or family members smoke near you? Yes No

If yes, what do you do when they are smoking near you? (select all that apply)

- Ask them to stop Leave the room Smoke I do not do anything

Other _____

Special Olympics
Health Promotion



Event	SO_Alaska_Ap
Number of athletes registered for event	38
Number of athletes attending event	38
Number of athletes screened at Health Promotion	22
% of athletes registered for event screened at Health	57.9 %
% of athletes who attended event screened at Health	57.9 %
Age Range	22 - 59
Age Average	38
Male	10 (26.3%)
Female	12 (31.6%)
Unknown	0 (0.0%)

	Total	20 - 29	30 - 39	40 - 49	50+
Blood Pressure Adult					
Hypotensive	0 (0.0%)	0 (0.0%)	0 (0.0%)	0 (0.0%)	0 (0.0%)
Normal	12 (75.0%)	3 (100.0%)	1 (100.0%)	1 (50.0%)	7 (70.0%)
Hypertension Stage 1	3 (18.8%)	0 (0.0%)	0 (0.0%)	0 (0.0%)	3 (30.0%)
Hypertension Stage 2-4	1 (6.3%)	0 (0.0%)	0 (0.0%)	1 (50.0%)	0 (0.0%)
Total	16	3	1	2	10
Body Mass Index Adult					
Underweight (BMI <18.5)	0 (0.0%)	0 (0.0%)	0 (0.0%)	0 (0.0%)	0 (0.0%)
Healthy weight (BMI 18.5 - 24.9)	1 (7.7%)	0 (0.0%)	0 (0.0%)	0 (0.0%)	1 (10.0%)
Overweight (BMI 25 to 29.9)	5 (38.5%)	1 (33.3%)	0 (0.0%)	0 (0.0%)	4 (40.0%)
Obese (BMI 30 and over)	7 (53.8%)	2 (66.7%)	0 (0.0%)	0 (0.0%)	5 (50.0%)
Total	13	3	0	0	10
Bone Density					
At risk for Heavy Metal Exposure	0 (0.0%)	0 (0.0%)	0 (0.0%)	0 (0.0%)	0 (0.0%)
Normal	0 (0.0%)	0 (0.0%)	0 (0.0%)	0 (0.0%)	0 (0.0%)
At risk for Osteopenia	0 (0.0%)	0 (0.0%)	0 (0.0%)	0 (0.0%)	0 (0.0%)
At risk for Osteoporosis	0 (0.0%)	0 (0.0%)	0 (0.0%)	0 (0.0%)	0 (0.0%)
Total	0	0	0	0	0

	8 - 19
Blood Pressure Youth	
Hypotensive	0 (0.0%)
Normal	0 (0.0%)
Hypertension Stage 1	0 (0.0%)
Hypertension Stage 2-4	0 (0.0%)
Total	0
Body Mass Index Youth	
Underweight (BMI <= 5th Percentile)	0 (0.0%)
Normal (BMI > 5th & < 85th Percentile)	0 (0.0%)
Overweight (BMI >= 85th Percentile)	0 (0.0%)
Obese (BMI >= 95th Percentile)	0 (0.0%)
Total	0

Tobacco	
Use tobacco products	0 (0.0%)
Second hand smoke	2 (66.7%)

Cardiovascular Risk Factors (Tobacco, BMI, BP, vitamin D supplement)	
Adult – 2 risk factors	2 (9.1%)
Adult – 3 risk factors	0 (0.0%)
Adult – 4 risk factors	0 (0.0%)

Athlete Self-Reported Physical Activity Habits	
Exercise for at least 30 minutes	21 (95.5%)
No days	1 (4.5%)
1-2 days	3 (13.6%)
3-6 days	4 (18.2%)
Every day	10 (45.5%)
Exercise outside Special Olympics Training (yes)	15 (68.2%)

Bone Density	Any tobacco exposure	Calcium consumption (3+)	Vitamin D supplement use
At risk for Heavy Metal Exposure	0 (0.0%)	0 (0.0%)	0 (0.0%)
Normal	0 (0.0%)	0 (0.0%)	0 (0.0%)
At risk for Osteopenia	0 (0.0%)	0 (0.0%)	0 (0.0%)
At risk for Osteoporosis	0 (0.0%)	0 (0.0%)	0 (0.0%)
Total	0	0	0



Special Olympics **Health Promotion**

**Chapter Five:
Education Stations**

Background Information

Education Stations address public health priorities that target lifestyles and behaviors shown to impact non-communicable disease health outcomes. The chosen topics address risk factors affecting Special Olympics athletes and coincide with global priorities identified by the World Health Organization (WHO) and regional Ministries of Health. The Health Promotion priority topics include the following. References to WHO and UNICEF international goals for the HP priority topics for nutrition, bone health, hydration, sun safety, physical activity, tobacco avoidance and handwashing are listed below:

- **Nutrition:** http://www.who.int/elena/titles/summary_eLENA_interventions_linked_global_targets.pdf?ua=1
- **Bone Health:** https://www.who.int/nutrition/topics/5_population_nutrient/en/index25.html
- **Hydration and the reduction of sugar sweetened beverages:** https://www.who.int/elena/titles/ssbs_childhood_obesity/en/
- **Sun Safety and Vitamin D:** https://www.who.int/uv/sun_protection/en/ and <https://www.who.int/bulletin/volumes/85/5/06-035089/en/>
- **Physical activity:**
 - Adults: https://www.who.int/dietphysicalactivity/factsheet_adults/en/
 - Young People: https://www.who.int/dietphysicalactivity/factsheet_young_people/en/
- **Handwashing:** <https://globalhandwashing.org/unicef-resource-guide-for-global-handwashing-day-2016/> and <https://news.un.org/en/story/2015/10/512662-handwashing-day-unicef-warns-inadequate-hygiene-endangers-key-development-goal>
- **Tobacco avoidance:** <https://www.who.int/news-room/fact-sheets/detail/tobacco>
- Many of our stations broadly address issues related to non-communicable diseases. <https://www.who.int/gho/ncd/en/>

Clinical Directors may find that their country, state, provincial, indigenous and local health authorities offer culturally relevant health promotion materials for populations within their jurisdiction. Many are available in an electronic format. These materials may be ready to use or be appropriate for use in Health Promotion with adaptation.

Sample templates for Education Station planning and activities for each topic are included in this manual, but Clinical Directors may also be interested in developing lesson plan(s) addressing Health Promotion priority topics for their events. We encourage that, provided the key messages are maintained.

Equipment and Tools

Recommended equipment and supplies for the HP Education Stations, are found in [Chapter 2, Supplies and Equipment Ordering Information](#).

Station Layout – Education Stations

The layout for the education stations will vary, based on your event and venue, but the ideal Health Promotion Education Station is colorful, educational, inviting and tidy and include the following features:

1. Volunteers are asked to stand up during the event. If you sit behind a table, you lose the opportunity to best promote your topic and engage the athletes. No food or beverages other than water should be consumed at the station.
2. Before the event, volunteers should be trained on their role at the station including how to brief others who take over when their volunteer shift changes. [See Volunteer Management Chapter 7 for examples of training tools.](#)
3. Volunteers will share key **population-based** messages from the posters with individuals or groups of athletes. These key-messages as presented on the station specific poster. Each program should have complete sets of the HP education station posters including Nutrition, Bone Health, Sun Safety, Hydration, Physical Activity, Handwashing, Tobacco Avoidance and Blood Pressure

Posters are available for download in a variety of sizes and layouts at Education Station Posters - Horizontal [USA – \(PDF\)](#) [Non-USA \(PDF\)](#)
Educational Station Posters Vertical [USA - \(PDF\)](#) [Non-USA \(PDF\)](#)

BEST PRACTICE:
Retractable posters come in a variety of sizes and are an ideal way to display posters as they can be placed in visible locations.

Prior to the event the HPCD should learn how station posters will be displayed, e.g., on an easel or on the wall behind the station.

4. Stations should include an **interactive game, challenge, activity** or demonstration to show a key message and engage athletes.
5. If **incentives** are offered, they will ideally reflect an educational message from the poster.
6. To help keep **health education “fresh”**, we recommend that the look of the education station changes from year to year, especially if the same athletes will visit HP from one year to the next. A catalogue of education station examples including suggested materials and interactive games and activities will be added to the Health Promotion resources website overtime. Please include photos as part of the evaluation report for capacity grants and/or email photos to the [SOI Health Promotion Manager](#).
7. At the **close of the event**, materials and supplies for the individual station should be inventoried and stored “by station”. If materials need to be replenished, repaired or replaced before the next inform the event notify the Program’s Healthy Athletes coordinator verbally and in writing.

Nutrition



Nutrition Station

How is Nutrition relevant to the Special Olympics athlete?

Several health habits contribute to chronic disease, including nutrition choices often are within the control of the individual. The goal of the nutrition component of Health Promotion is to provide the athlete with information and skills to make healthy food and beverage choices.

Individuals with intellectual disabilities (ID) are at increased risk for obesity, osteoporosis, heart disease, seizures, poor physical conditioning and fitness as well as other medical conditions. They often experience nutrition challenges including growth alterations such as failure to thrive, obesity, and growth retardation, metabolic disorders, medication-nutrient interactions, and food/sensory challenges. Foremost among those challenges is having the tools and the knowledge to help the individual enjoy and maintain full, healthy lives.

Data collected at previous Special Olympics World Games, regional and local events indicate that many of the athletes are overweight or obese; are at risk for osteoporosis and osteopenia and consume less than the recommended servings of dairy foods, and fruits and vegetables.

We offer three education stations that promote healthy nutrition. If space or volunteers are limited, you may be able to combine these two or three stations into one that still focuses on the key messages.

- **Nutrition Station** - promotes 5 fruits and vegetables a day
- **Hydration Station** - promotes water as a beverage, avoidance of sugar sweetened beverages and hydration.
- **Strong Bones Station** - promotes bone building foods and beverages, strength and weight bearing activities and adequate vitamin D to influence strong bones across the lifespan.

Station Purpose - Nutrition

Displays, interactive education activities, food samples, food demonstrations and positive messages about foods and beverages are used to promote healthy eating.

Objective - Athletes

Through participation at this station, athletes will be able to demonstrate that they grasp at least one of the following concepts.

Athletes will be able to:

1. Identify items for of a healthy meal and portion control.
2. Understand the recommended number of fruits and vegetables.
3. Explain the importance that nutrition can have on their health, life, and their sport performance.



Key Messages - Nutrition

The key messages for this education station are found on the Fruits and Vegetables Poster ([US](#) | [Global](#)) and include:

- Eat at least 5 fruits and vegetables every day.
- Make half your plate fruits and vegetables.
- Include fruits and vegetables during sports time.
- Ways to increase fruits and vegetables every day.
- Track your daily fruits and vegetable on the Fit 5 Tracking Tool.



Additional nutrition topics for the Nutrition Education station, to address the key elements of health eating patterns as included in [international dietary guidelines](#) include



- Focus on eating a variety, nutrient-dense foods, and watch portion sizes
- Eat a variety of protein foods, including seafood, lean meats and poultry, eggs, beans and peas, nuts and seeds, dairy and soy products.
- Include no fat and low-fat dairy products in daily diet.
- Make half your grains whole.
- Make half your plate fruits and vegetables and focus on whole fruits.
- Choose foods and beverages with less saturated fat, sodium and added sugars.

Interactive Station Activities - Nutrition

The Clinical Director and volunteers can choose one or more interactive activities for the Nutrition Education Fruits and Vegetable Education Station. Each of the activities can be completed with an athlete or with a small group of athletes.

Four Sample Lesson Plans – Nutrition

Activity	Activity Description	Equipment/Supplies	Set up	Talking points
<p>Foods that Make Me Healthy</p> 	<p>Athlete selects items they like to eat or drink. Ask them to sort into those that make them healthy and strong and those that don't (<i>Use the smile face and not smile face for sorting</i>).</p> <p>Volunteer comments on the choices and healthy not healthy category and asks athlete what they think.</p>	<ul style="list-style-type: none"> ✓ Assortment of foods, plastic food models, beverage containers or pictures of foods (include healthy and not healthy) ✓ Black electrician tape or smile face and not smile face picture ✓ Table (4' long) 	<p>Foods (pictures or models) on table with sign for healthy/not healthy placement.</p>	<p>Discuss substitutions for unhealthy choices and reinforce the healthy choices, for example <i>Try water instead of a sweet beverage.</i></p> <p>Appendix 1 includes a list of food and beverage items and suggested replacements/comments</p>
Activity	Activity Description	✓ Equipment/Supplies	Set up	Talking points
<p>Build a Meal</p> 	<p>Athlete selects items to build a meal, could be breakfast, lunch or supper.</p>	<ul style="list-style-type: none"> ✓ Assortment of foods, plastic food models, beverage containers or pictures of foods (include healthy and not healthy) ✓ Paper plate or plastic plate ✓ Table (4' long) 	<p>Foods (pictures or models) on table for athlete to select and place on plate</p>	<p>Important to eat a variety of foods from each group, remember ½ of plate should be fruits and vegetables.</p> <p>Highlight the health choices and fruits and vegetables.</p>

<p>Mystery Fruit and Vegetable</p> 	<p>Introduce athlete to a variety of fruits and vegetables. Good for introduction of new foods for athletes' Athlete reaches into bag/box and guesses what the food it</p>	<ul style="list-style-type: none"> ✓ Paper bag or box with cover ✓ Fruits and vegetables (about 5-7) representing different shapes, size and texture) 	<p>Place fruits/vegetable in bag/box</p>	<p>Discuss if athlete has eaten the food item, if not – would they like to try it? Discuss the feel, taste, smell. Fruits and vegetable are fun, they are colorful, add flavor, some feel different—what is your favorite?</p>
<p>Power up for Sports</p> 	<p>Athlete selects foods & beverages that would be good for in between meals and after sports event/practice.</p>	<ul style="list-style-type: none"> ✓ Assortment of foods, plastic food models, beverage containers or pictures of foods ✓ Fit 5 Tracking Tool ✓ Table 4'long 	<p>Foods (pictures or models) on table for athlete select and discuss.</p>	<p>Plan healthy snacks and meals for every day and help your sport performance. Example: <i>What is a good food to take to sport practice- try a banana – <u>the original grab and go food</u></i> Give athlete the Fit 5 Tracking Tool and discuss area where fruits and vegetables can be tracked.</p>

Another example of “Foods That Make Me Healthy” sequential photos teaching nutrition in Greece. It works well with individuals as well as groups or teams. Its best to have options of healthy foods as well as high calorie low nutrient items so athlete can learn how to choose healthier options. Include packaged foods as well as plastic food models if possible. Consider adding simple nutrition label education, too!

A Special Olympics Athlete from Greece shows volunteers which foods he likes.





Bone Health

Bone Health Station

How is Bone Health relevant to the Special Olympics athlete?

Bone health is important for Special Olympics athletes around the world. People with ID are at higher risk for bone fracture than the general population. For many athletes, getting enough calcium, vitamin D and other nutrients, is a challenge. Many athletes do not engage in daily physical activity, and even for those who do, the exercise might not be vigorous enough to positively stress bones. For all athletes, it is important to include bone building nutrients and vigorous physical activity into their daily lives.

Having strong bones supports athlete participation in sports and in social activities like dancing and other group activities. Strong bones carry us through busy workdays and allow us to enjoy playing, running, jumping, climbing all the fun-filled physical activities we love. As the athlete trains and competes, if the bone nutrients are available, bone density will improve. Exercise without adequate calcium, vitamin D, magnesium and potassium doesn't improve bone strength. Likewise, even the most excellent nutrition will not improve bone density without exercise. To build and maintain strong bones practicing healthy behaviors throughout life, the earlier the better. These include healthy eating, daily physical activity, avoiding alcohol and tobacco, assuring safe sun exposure and/or taking supplements to insure adequate vitamin D.

Station Purpose – Bone Health

Activities and information shared at **Strong Bones** will build athlete understanding that their food and beverage choices, physical activity, safe sun exposure and/or use of vitamin D supplements all impact their bone strength.

Objective - Athletes

Through participation at this station, athletes will be able to demonstrate that they grasp at least one of the following concepts. Athletes will be able to:

1. Identify the healthy, strong bone, one that is not weak and one that represents a fracture on Easel.
2. Match, select, or name foods and beverages that promote bone health.
3. Describe or show physical activities that enhance bone health.
4. Choose one step they will take to promote bone health from the Strong Bones poster.
5. Explain two ways to get vitamin D; from the sun shining on their skin, or from supplements.

Key Messages – Bone Health

Key messages for this station are found on the Strong Bones Poster ([US](#) | [Global](#)). The messages emphasize athlete behaviors that can improve bone health and prevent fractures including:

- Good nutrition helps build strong bones for life.
- Being active helps keep your bones strong to resist breaking, and your balance steady to prevent falls.
- Sensible sun exposure and/or vitamin D supplements are needed for bone health.
- If bones are not strong, they can break more easily.
- Tobacco and alcohol cause damage to bones.

Interactive Station Activities – Bone Health





The Clinical Director and volunteers can choose one or more interactive activities that promote the key messages for bone health. Each of the activities can be completed with an individual athlete or with a small group of athletes.



See Health Promotion Resources for descriptions and images of suggested station activities

Five Sample Interactive Station Ideas – Bone Health:

Activity	Activity Description	Equipment/Supplies	Set up	Talking points
<p>Foods I like that build strong bones</p>	<p>Athlete selects favorite foods and beverages with calcium and vitamin D.</p> <p>Athlete then puts the ones they like in a separate area so they can see how many options there are.</p>	<ul style="list-style-type: none"> • Station poster • Empty packages, faux foods or photos of calcium and vitamin D containing foods and beverages. • Use photos of milks, cheeses and yogurts as well as dark green leafy veggies from your grocery store. • Nutrition labels for some products. • Appendix 2: Milk comparison chart 	<p>Faux food, food and beverage containers or photos of CA and D items out on the table. Leave space for athlete to put their choices.</p>	<ul style="list-style-type: none"> • Ask athlete if they eat or drink calcium and vitamin D source foods. • Advise athletes who don't eat, or drink listed foods to talk with parents and doctor about CA and D supplements.
<p>Physical activities to build strong bones</p>	<p>Athlete learns how sports and daily activities improve bone health. Show sports icons for local programs sports and images of “chores”.</p> <p>Demo fit 5 exercises if not used in physical activity station</p>	<ul style="list-style-type: none"> • Station poster • A poster with our sports logos, a yoga pose poster, exercise props: yoga mat, small hand weights, stretch bands with handles 	<p>Have an enthusiastic volunteer with fitness, dance or yoga skills. Using listed supplies, demonstrate chosen activities</p>	<ul style="list-style-type: none"> • Refer to poster to discuss weight bearing, strength and balance activities to strengthen bones • Ask which builds strength, is weight bearing, and improves balance.

<p>Loss of a Bone Easel</p> 	<p>If Bone Health is combined with a second station, hold a discussion about visual difference between strong and weak bones and fracture prevention.</p>	<ul style="list-style-type: none"> • Station Poster • Loss of a Bone Easel • Faux milk and dairy products 	<p>Easel, calcium and D rich foods and drinks (pictures, faux foods, empty containers.</p>	<ul style="list-style-type: none"> • Can you tell which of these bones is broken? How does it look compared to the other bone? • Did you ever break a bone? How? Did it hurt? • What activities, sports and foods help keep your bones strong?
<p>Skeleton Puzzle</p> 	<p>Athletes assemble puzzle to reinforce idea that their body needs healthy bones. The puzzle table may go alongside the test area so athletes can work on it while they wait their turn.</p>	<ul style="list-style-type: none"> • Skeleton puzzle and skeleton poster • Cups of faux milk and dairy foods, empty cartons of 1% or skim milk and alternatives with calcium and vitamin D. 	<p>A table with the unassembled puzzle.</p> <p>Athletes can work on it while they wait their turn for bone mineral density test.</p>	<ul style="list-style-type: none"> • Ask athlete to point to their longest bone; smallest finger, roundest bone. Did s/he ever break a bone? Which one? How did it break, and did it heal well? • Drink calcium and D rich beverages
<p>Milk Moustache Photos</p> 	<p>Athlete or team picture in front of station poster or take a selfie with milk moustache and glass or bottle of milk</p>	<ul style="list-style-type: none"> • Smart phone. • Giveaway of bottled milk, string cheese, sugar-free lite yogurt. 	<p>Milk moustaches (white) stickers. Inflatable cow, faux or bottled white milk.</p>	<ul style="list-style-type: none"> • Discuss poster key messages. • Drink 2-3 cups of milk daily • The team photo will remind athletes to drink milk after the event.



Hydration

Hydration Station

How is Hydration relevant to the Special Olympics athlete?

Water is important for the health of Special Olympics Athletes across the world. In some countries, athletes may need to understand the importance of clean and safe water. In other countries like the United States, the message for the athletes should be to limit the number of sweetened beverages and chose more water. For all athletes regardless of location, it is important to drink adequate amounts of water during exercise and sports.

Adequate hydration and fluid replacement are important nutritional concerns for an athlete. Ensuring that all athletes are adequately hydrated is critical. A loss as small as 4 percent of body weight (4 pounds in a 100-pound person) can seriously affect performance and the athlete’s health.

Station Purpose – Hydration

Displays, interactive education activities, beverage samples, demonstrations and positive messages about hydration are used to promote healthy beverage choices, obtain an adequate fluid intake and educate on the signs of dehydration.

Objective – Athletes

After participation in one or more Hydration Station activities the athlete will be able demonstrate and to discuss, at least one of the following:

1. Beverages high in sugar, identify a beverage lower in sugar.
2. How it feels to be dehydrated.
3. Commitment to drink more water- use Selfie.
4. How to use the Fit 5 Tracking Tool to increase water consumption on a daily basis.

Key Messages – Hydration

Key Messages for this station are found on the Hydration Poster ([US](#) | [Global](#)), and include:



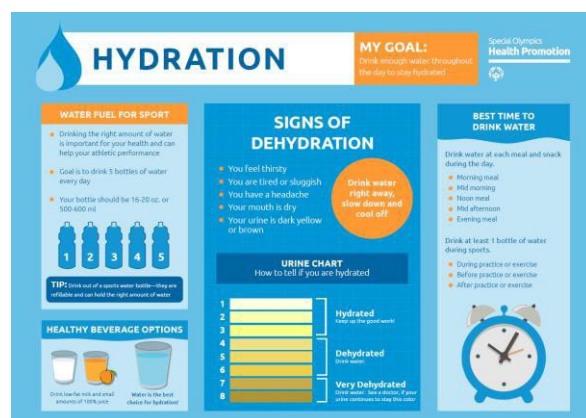

- Water is an important for sport performance
- Drink at least 5 bottles of water every day
- Healthy beverage options for hydration
- Signs of dehydration
- Important times to drink water



Interactive Station Activities – Hydration

The Clinical Director and volunteers can choose one or more interactive activities for the Hydration Station. Each of the activities can be completed by an individual athlete or a small group of athletes.

Four Sample Interactive Station Ideas – Hydration:

Activity	Activity Description	Equipment/Supplies	Set Up	Talking Points
<p>Rethink Your Drink</p> 	<p>An interactive spin the wheel game. Athlete spins the wheel, lands on a beverage and responds to questions</p>	<p>Rethink Your Drink Wheel (template available at HP website) in English/ Spanish</p>	<p>Tabletop Wheel, empty generic beverage bottle pictures</p>	<p>Ask athlete if the beverage has sugar, and do they know how much? Show the amount (on generic beverage picture). Discuss healthy alternative beverage. Promote water as the beverage of choice.</p> <p>Give athlete the Fit 5 Tracking Tool and discuss area where water can be tracked.</p>
<p>How Much Sugar?</p> 	<p>Interactive education, athlete selects a photo or bottle and estimates how much sugar is in the beverage.</p>	<p>Generic photos or clear containers with varying amounts of sugar</p>	<p>Display on tabletop of familiar beverage pictures or containers.</p>	<p>Volunteer shows athlete the amount (s) and discusses healthy alternative beverages. Promote water as the beverage of choice.</p>
<p>Sponge Demonstration</p> 	<p>Visual image of hydration and dehydration</p>	<p>Bowl of water sponge, paper towels</p>	<p>Sponge and water on tabletop.</p>	<p>Full sponge illustrates hydration, squeeze the sponge, water leaves the body and you dehydrate. How would you feel? What would you need to do to replace lost water?</p> <p>Promote water and signs of dehydration on poster.</p>
<p>Selfie with Water</p> 	<p>Athlete or team picture in front of hydration poster, take a selfie with a bottle of water or cup drinking water</p>	<p>Athlete or individual smart phone Hydration poster Water to give away</p>	<p>Poster Water to give away</p>	<p>Drink at least 5 bottle of water every day, use poster to discuss other key points. Your picture should remind you to drink water.</p>



Sun Safety

Sun Safety Station

How is Sun Safety relevant to the Special Olympics athlete?

People with intellectual disabilities have greater health disparities and health care needs. Vitamin D deficiency is prevalent in people with intellectual disabilities, partly because of insufficient sun exposure. We teach athletes to enjoy time in the sun while protecting themselves from sunburn. Outdoor sports allow athletes to get healthy sun exposure. But no matter the season, the risk of sun burn for athletes is there if proper protection isn't practiced.

The frequency and severity of sun burn is a risk factor for skin cancer. Athletes with lighter skin and hair color, those living at higher elevations, those who work indoors most days with intermittent intense sun exposure and those who take medicines that make skin more sensitive to sunlight are at higher risk for sunburn.

Some athletes are particularly sensitive to the sun's UV rays. For people with photosensitivity, even a small dose of UV radiation triggers an allergic reaction leading to rash or sunburn. Photosensitivity is also associated with the use of [certain medications](#) often used by our athletes. Those who use medication on a regular basis should refer to the package insert or consult the health care provider or pharmacist about possible photosensitivity reactions.

Station purpose – Sun Safety

Displays, interactive education activities, demonstrations and positive messages about sun safety help athletes understand how to:

- Balance enjoying time in the sun with sunburn avoidance.
- How to be safe in the sun, avoid getting a sunburn, protect eyes and avoid getting over heated.
- How to get vitamin D from the sun, food and supplements

Objective – Athletes

Through participation at this station, athletes will be able to demonstrate that they understand at least one of these concepts:

1. Identify the three ways they can prevent getting sunburned, e.g., use shade, wear a brimmed hat, wear protective clothes during mid-day sun, use SPF sunscreen and lip balm, UV sunglasses.
2. Identify three foods or beverages that have vitamin D
3. Describe how to get vitamin D from the sun and not get burned.
4. Explain two ways to get vitamin D; from the sun shining on their skin, or from supplements.

Key Messages – Sun Safety

Key Messages for this station are found on the **Sun Safety Poster (US | Global)** and include:

- Take steps to avoid sunburn, protect skin and eyes during mid-day sun year-round. Here's how:
 - Wear protective clothes e.g., wide brimmed hats, long sleeve shirts including when swimming
 - UV protective eyewear and lip balm when in the sun
 - Use at least SPF 15 sunscreen on areas susceptible to sunburn. Don't get in your eyes. Note: When discussing sunscreen, caution athletes to keep it out of their eyes to avoid a chemical burn. [Learn more here.](#)
 - Find and stay in the shade when sun is intense and highest in the sky, 10 am – 2pm
- Enjoy outdoor activities year-round. Exposing our skin to sunshine lets us [take advantage of the health-giving properties the sun provides.](#)
- Our bodies need Vitamin D which is made from sunlight.







Interactive Station Activities – Sun Safety

The Clinical Director and volunteers can choose one or more interactive activities for the Sun Safety Station. Each activity can be completed by an individual athlete or a small group of athletes.

Five Sample Interactive Station Ideas – Sun Safety:

1. What are the 4 stages of sunburn?
2. How protective clothing, eyewear and SPF products help prevent sunburn for year-round sports
3. Using shade to help prevent sunburn.
4. Ways to vitamin D from sun exposure, foods and vitamin pills.

Activity	Activity Description	Equipment/Supplies	Set Up	Talking Points
<p>Protect yourself from sunburn during practice and sports</p>  <p>competition.</p>	<p>Pack your bag to protect yourself at your sport practice – what would you put in it (and then they pick from several props)</p>	<p>Various sun protective hats, ski face mask, UV sunglasses, UV snow and/or swim goggles,</p> <p>SPF 15-30 sunscreen, lip balm, swim shirts, a picture of shade from a tree or building, gym bag.</p>	<p>Display of multiple sun protection products, plus some items that aren't related so athlete can choose.</p>	<p>How do you protect yourself from sunburn during sport practice?</p>
Activity	Activity Description	Equipment/Supplies	Set Up	• Talking Points

<p>Protective clothing and eyewear help prevent sunburn year-round</p> 	<p>Athlete puts protective items on Styrofoam head, pretends to put sunscreen on exposed parts of the face. Pretends to give head a vitamin D pill</p>	<p>Styrofoam head, various sun protective hats, ski face mask, UV sunglasses, UV snow and/or swim goggles, SPF 15-30 sunscreen</p> <p>lip balm, swim shirts, vitamin D bottle.</p>	<p>Display props on table with sunny day theme.</p>	<ul style="list-style-type: none"> • What kind of hat is used to shade their face? Use sunscreen on unshaded areas. • How do athletes protect eyes and face from sunburn during winter sports? • How do swimmers protect shoulders, neck, face and arms from sunburn? • Show UV eyewear, lip balm sunscreen labels
<p>Enjoy time in the sun and protect yourself from sunburn</p> 	<p>Athlete spins the wheel. When the wheel stops, athlete says what the image has to do with sun safety.</p>	<p>Prize wheel image ideas: clock, umbrella, sun hat, UV eyewear, UV lip balm, bracelets, sunscreen, vitamin D, sun, sunburn.</p>	<p>Prize wheel with sun protection images. items, vitamin D bottle, solar bracelets.</p>	<p>When the spinner stops on an image, the athlete will describe how image relates to sun safety. Volunteer reiterates the information, and the athlete (or team) either gets a prize or the audience claps.</p>
<p>Get vitamin D even if you avoid the sun</p> 	<p>Athlete identifies the three ways to get vitamin D; from the sun, supplements and food. Have athlete point to where they live on the globe to highlight distance from equator.</p>	<p>Station poster, sun balloon, vitamin D bottle, vitamin D faux foods or cartons of skim + 1% milk, light yogurt, fortified cereal, sardines. Photos of foods and drinks with vitamin D can also be used, a globe.</p>	<p>Display props on table with sunny day theme.</p>	<p>What are three ways to get vitamin D?</p>
<p>Use shade wisely</p> 	<p>Alert athlete to use shade to prevent sunburn and overheating</p>	<p>Have photos of items and the actual items when possible. Umbrella, shade tree pictures & canopy, brimmed hats. Clock marked for mid-day.</p>	<p>Display props on table with sunny day theme.</p>	<p>How do you find or make shade on a sunny day? Use talking points from poster that promote shade as sun protection. Show hats clothing, umbrellas shade your skin from sun</p>

References Sun Safety:

1. World Health Organization Bulletin: The current public health message on UV exposure overlooks many health benefits <https://www.who.int/bulletin/volumes/85/5/06-035089/en/>
2. World Health Organization - Skin Cancers: https://www.who.int/uv/health/uv_health2/en/index1.html
3. World Health Organization - Ultraviolet Radiation: www.who.int/topics/ultraviolet_radiation/en/
4. World Health Organization - In defense of the sun: an estimate of changes in mortality rates in the United States if mean serum 25-hydroxyvitamin D levels were raised to 45 ng/mL by solar ultraviolet-B irradiance? *Dermatoendocrinol.* 2009;1(4): 207-214. www.ncbi.nlm.nih.gov/pmc/articles/PMC2835876
5. Vitamin D for Health: A Global Perspective; Hossein-nezhad, Arash et al. *Mayo Clinic Proceedings* Volume 88 Issue 7 , www.ncbi.nlm.nih.gov/pubmed/23790560
6. World Health Organization - Sun protection: Enjoy the sun, but enjoy it safely: https://www.who.int/uv/sun_protection/en/

Physical Activity



Physical Activity Station

How is Physical Activity relevant to the Special Olympics athlete?

Regular physical activity is vital for children and adults with intellectual disabilities. There is strong evidence that physical activity positively affects balance, muscle strength, and quality of life in individuals with intellectual disability. Adults with *disabilities* are three times more likely to have heart disease, stroke, diabetes, low bone density or cancer than adults without *disabilities*. *Aerobic physical activity* can help reduce the impact of these chronic diseases, yet nearly half of all adults with *disabilities* get no leisure time aerobic *physical activity*.

Physical fitness is a key part of the Special Olympics mission. Fitness is the state of optimal health and performance through adequate physical activity, nutrition and hydration. It involves practicing healthy habits year-round and lifelong. Being fit supports athlete participation in sports and in social pursuits like dancing and other group activities. Fit bodies carry us through busy workdays and allow us to enjoy playing, running, jumping, climbing fun-filled physical activities we enjoy.

Station Purpose – Physical Activity

Activities and information shared at the Physical Activity education station help build athlete understanding that their physical activity helps them maintain good health, feel better and lower the risk of chronic disease. The Health Promotion Physical Activity education station and materials emphasize movement and vigorous physical activity opportunities in their daily lives, in addition to their routine sports training and completion. Setting goals may enhance athlete's interest in participating in 30 minutes of moderate intensity physical activity on most days of the week.

Objective – Athletes

Through participation at this station, athletes will be able to demonstrate that they understand at least one of these concepts:

1. Identify a type of sport training they do that improves strength, improves endurance or improves balance.
2. Describe daily chores they can do that promote physical fitness
3. Describe fun activities to replace screen time that are active and promote fitness.
4. Choose one step they will take to promote their fitness and physical stamina from the Physical Activity poster.

Key Messages – Physical Activity

Key messages for this station are found on the **Physical Activity poster (US | Global)**.

The messages emphasize athlete behaviors and enhanced fitness and include:



1. Physical activity is anything you do that makes you move. For health benefits, physical activity should be moderate or vigorous intensity.
2. Being active helps keep your body strong, flexible and at peak performance.
3. Physical activity benefits overall health, sports performance and reduces injury risk.
4. Physical activity helps athletes achieve their personal best and enjoy sports for their entire life





Interactive Station Activities – Physical Activity

The Clinical Director and volunteers can choose one or more interactive activities for the Handwashing Station. Each of the activities can be completed by an individual athlete or a small group of athletes.

Five Sample Interactive Station Ideas – Physical Activity:

Activity	Activity Description	Equipment/Supplies	Set Up	Talking Points
Fitness card demo with block or prize wheel	An interactive spin the wheel game. Athlete spins the wheel, lands on an activity, then tosses a dice for number of repetitions.	Fit 5 Fitness cards . Prize Wheel, large sponge dice with numbers on it. Or use a second dice with Fit 5 card images on sides of dice.	Prize wheel and dice with numbers Have volunteers with fitness or coaching skills.	<ul style="list-style-type: none"> • Being active helps keep your body strong, flexible and at peak performance. • Physical activity benefits your overall health, sports performance and reduces injury risk. • Physical activity helps you reach your personal best and enjoy sports all your life.
Yoga demo and challenge with photo opportunity 	An intro demo and practice of basic yoga poses. Athlete or team photo in yoga poses. We suggest coordinating with Strong Minds Clinical Director, if Strong Minds is also being offered so not to duplicate efforts.	Yoga mats, Get yoga poses poster in native language. 	Find volunteers with yoga experience, several mats	<ul style="list-style-type: none"> • Yoga can complement your exercise routine • It helps improve flexibility and balance, strength and muscles. • Yoga can help you to relax and lower stress.
Hula Hoop contest 	Several athletes compete to see who can keep the hula hoop going longest.	A variety of hula hoops including weighted ones.	Have volunteers who can teach the skill and encourage athletes to try it.	<ul style="list-style-type: none"> • Increase challenge by using heavier hoops. • It strengthens core, legs, front and back. • Ask athletes to point to the muscles that feel challenged after trying hula hoops.

Activity	Activity Description	Equipment/Supplies	Set Up	Talking Points
Pedometer or wrist step counter set up and demo 	Teach athletes how device works; how to set up, change battery, and use. Create short competition using device.	Pedometers or wrist step trackers. Enlarged image of directions to set. Instructional posters	Have a volunteer who can set the pedometer and teach others.	<ul style="list-style-type: none"> Setting fitness goals can help make healthy activity habits. Step counters can help you get in shape. Set small goals and take more steps over time. goals can provide increasing challenges from week to week.
Demo training exercise from team's sport 	Invite teams to demonstrate exercise drills for their sport. Challenge other teams to try to perform same drills. Highlights other sports offered in Program.	Poster showing icons for sports offered at current event, with picture of sports drill beside icon.	Staff with enthusiastic volunteers familiar with seasonal sports for event.	<ul style="list-style-type: none"> What sports do they play? Variety enhances overall health. Is there interest in trying another sport? Share info on other offered sports in Program. <p>What activities does the team do at practice? Refer to fitness programming if offered.</p> <p>Do athletes get together outside of practice and competition? Encourage social aspects of belonging to a team.</p>

References

Physical Activity

1. WHO Global Strategy on Diet, Physical Activity and Health
2. Physical Activity and Adults Recommended levels of physical activity for adults aged 18-64:
<https://www.who.int/dietphysicalactivity/physical-activity-recommendations-18-64years.pdf?ua=1>
3. Physical activity and young people Recommended levels of physical activity for children aged 5-17 years:
https://www.who.int/dietphysicalactivity/factsheet_young_people/en/
4. Introduction to Intellectual Disabilities and Fitness
<https://www.nchpad.org/120/931/Intellectual~Disabilities~~~Fitness>
5. Physical activity benefits and needs in adults with intellectual disabilities: systematic review of the literature.
<https://www.ncbi.nlm.nih.gov/pubmed/21591845>
6. Special Olympics Fitness Resources <https://resources.specialolympics.org/health/fitness>



Hand Washing

Handwashing Station

How is Handwashing relevant to the Special Olympics athlete?

Infectious diseases that are commonly spread through hand-to-hand contact include the common cold, flu, as well as many others. If an individual does not wash their hands frequently enough, they can become infected with germ through the action of touching their eyes, nose or mouth. Other people can become infected after coming into contact with a surface that the person carrying the germ has already touched.

Handwashing is our best defense against many kinds of bacteria and viruses that cause infection. It is especially important for Special Olympics athletes, coaches and volunteers to practice good handwashing habits since many individuals share sports equipment, practice facilities, food and beverages during Special Olympics events and practices. Moreover, some of our Special Olympics athletes might need additional guidance and support in using proper handwashing techniques.

Station purpose – Handwashing

Displays, interactive education activities, and positive messages about handwashing will provide athletes with information and an understanding of the importance and correct technique for handwashing. Country and local handwashing resources should be used to ensure the information is well understood and culturally appropriate.

Objective – Athletes

Through participation at this station, athletes will be able to demonstrate that they understand and demonstrate/discuss at least one of these concepts:

1. Germs from coughing, sneezing or from using the latrine, live on our hands and make us sick.
2. Germs on hands can be passed from person-to-person.
3. Handwashing with soap is more effective at killing germs & preventing illness than handwashing with just water.
4. The critical times each day to wash hands with soap.
5. The proper technique for handwashing with soap.

Key Messages – Handwashing

Key Messages for the station are found on the **Handwashing Poster (US | Global)** and include:

- Why handwashing is important
- When to wash your hands
- How long to wash your hands
- Easy steps to clean hands



Interactive Station Activities – Handwashing



The Clinical Director and volunteers can choose one or more interactive activities for the Handwashing Station. Each of the activities can be completed by an individual athlete or a small group of athletes.

Four Sample Interactive Station Ideas – Handwashing:

Handwashing and Hand Sanitizer Use:

The recommended method for handwashing is to use soap and water. Hand sanitizers are not a substitute for soap and water and should not be used at the Handwashing Education Station. If soap and water is not available, a handwashing demonstration and the Global Handwashing Dance are the best activities to promote proper handwashing technique.

Activity	Activity Description	Equipment/Supplies	Set Up	Talking Points
Global Handwashing Dance 	You Tube video demonstrates handwashing in a fun and interactive style.	Flatscreen TV with internet access or computer to show video. https://www.youtube.com/watch?v=825gGELjB98	Screen on table or stand. Volunteer may lead an athlete or group of athletes in the dance using exaggerated motions to add fun to the dance.	<ul style="list-style-type: none"> • Handwashing can be fun. • You need soap and water to wash your hands. • Scrub your hands, between fingernails and thumbs, rinse off soap.
Handwashing Demo (without water) 	Volunteer demonstrates proper handwashing technique, following the steps on the Handwashing poster.	Bar of soap, paper towels, bucket, wash cloth.	Engage the athletes to follow the volunteer in the activity. Water is not required for this activity.	<p>Handwashing is fun!</p> <p>Wash hands for 20 seconds. Sing the happy birthday to yourself twice, its 20 seconds! You need soap and water, and to scrub your hands, between fingers and thumbs, rinse soap.</p>

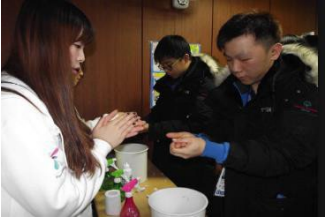
Activity	Activity Description	Equipment/Supplies	Set Up	Talking Points
<p>Glo Germ Handwashing</p>  	<p>The Glo Germ Kit contains special solution for a hand washing activity. Fluorescent particles “germs” are used and if not completely washed off, will show under an UV light.</p>	<p>Glo Germ Kit (includes glo germ lotion, glo germ power, small UV light). Warm running water, soap and paper towels are REQUIRED for this activity. Handwashing gels and sprays will not remove the Glo Germ. If running water not available a portable handwashing unit may be used or you can still use the UV light to show athletes what germs might already be on their hands, even without the use of the gel.</p>	<p>Set up poster and handwashing station near running water or a portable handwashing station. Instructions for the activity are in the appendix.</p>	<ul style="list-style-type: none"> • You need soap and water to wash your hands • Germs are not just on your hands but under and around your nails • Scrub your hands, between fingernails and thumbs, rinse off soap
<p>When to wash</p> 	<p>Photos prompts for interactive discussion of when to wash hands</p>	<p>Photos of toilet, petting an animal, playing sport, soap, plate with utensils, cut up fruit or vegetables. Photos are available on the Health Habits Photo Guide, copy and reprint those or use stuffed animal, sports ball and other items to identify the activities when handwashing is needed.</p>	<p>Place photos on table and ask athlete(s) to identify which photos are places/activities they should wash their hands after or before.</p>	<ul style="list-style-type: none"> • It is important to wash your hands after many activities or before eating. These are just a few, can you think of others?

Tobacco Cessation & Avoidance



Tobacco Cessation & Avoidance Station

How is Tobacco Cessation & Avoidance relevant to the Special Olympics athlete?

The World Health Organization (WHO) states that “tobacco is the leading cause of death, illness and impoverishment.” The tobacco epidemic is one of the biggest public health threats the world has ever faced, killing more than 8 million people a year around the world. More than 7 million of those deaths are the result of direct tobacco use while around 1.2 million are the result of non-smokers being exposed to second-hand smoke.” For more information:

<https://www.who.int/news-room/fact-sheets/detail/tobacco>

Tobacco use by Special Olympics Athletes varies considerably. Some athletes may not use tobacco themselves but may be in the presence of others who smoke, and therefore are exposed to second-hand smoke. The tobacco prevention station will help address the concerns relevant to each athlete. Some may use chewing tobacco, cigarettes, electronic cigarettes, vaping devices, pipes and want to quit. Some may want to know how to ask others around them to not smoke near them. Still others may be worried about the tobacco use of family or friends. The suggested activity helps demonstrate the long-term impact of cigarettes on health and sports performance.

Station purpose – Tobacco Cessation & Avoidance

Displays, interactive education activities, and positive messages about tobacco prevention will provide athletes with information and an understanding of the impact of tobacco on their health. Country and local tobacco avoidance resources will be shared to assist the athlete in seeking additional support.

Objective – Athletes

Through participation at this station, athletes will be able to demonstrate that they understand at least one of these concepts

1. Physical impact of cigarette smoking on their breathing after vigorous activity.
2. Engage in discussion on tobacco use and the effect on their health and sports performance.
3. Explore ways an athlete can comfortably ask others no to smoke around them.
4. State the harmful effects of tobacco use.

Key Messages – Tobacco Cessation & Avoidance

Key Messages for this station are found on the **Tobacco Poster (US | Global)** include:

- Why tobacco avoidance is important
- Avoid tobacco in all forms
- Choose sports, not tobacco
- Strategies for avoiding secondhand smoke
- If you avoid tobacco, you can perform better



Interactive Station Activities – Tobacco Cessation & Avoidance

The Clinical Director and volunteers can choose one or more interactive activities for the Tobacco Avoidance & Cessation Station. Each of the activities can be completed by an individual athlete or a small group of athletes.

Four Sample Interactive Station Ideas – Tobacco Cessation & Avoidance:



Activity	Activity Description	Equipment/Supplies	Set Up	Talking Points
<p>Where is my air?</p> 	<p>Athletes will first breathe through a straw and again after vigorous activity (running in place or jumping jacks) for 30 seconds. The athletes are then asked to breathe and again. They will experience breathing challenges similar to a person who smokes.</p>	<p>Disposable drinking straws, stopwatch or timer.</p>	<p>Table for straws, area for athletes to conduct a vigorous activity.</p>	<ul style="list-style-type: none"> • Explain to athletes that they will see how smoking affects their breathing after exercise. • Give each athlete a straw and ask them to breathe through the straw. • Ask the athletes how they feel- was it easy? • Ask the athletes to run in place or do jumping jacks for 30 seconds and then breathe through the straw again. Volunteer can participate and if music is available, it can enhance the activity. • Ask the athletes if they feel different? Most will say yes, it is harder to breathe, and some may be coughing. • Discuss with athletes that cigarette smoking is not good for their health and sports performance. What do they think?

Activity	Activity Description	Equipment/Supplies	Set Up	Talking Points
Gross Mouth Photos See Chapter 5	Photographs illustrate the impact of tobacco on teeth, gums and tongue of smokers		Photos in sheet protectors in three ring binder	Discuss with athletes what they see in the pictures and how tobacco (cigarette, chew, pipe, vaping, electronic) can impact your mouth.
Tar Jar Demo 	Tar jar demonstrates how much tar goes into the lungs of a smoker in one year.	Jar filled with molasses and cigarette butts, lid on. See appendix for jar assembly instructions or purchase information.	Jar on table	<ul style="list-style-type: none"> • Ask athletes how long it would take for a 1 pack a day smoker to get this much tar in their lungs. • Discuss what tar has to do with a cough the smoker may have. • Relate the cough to the Where is my air activity.
What to Say 	Interactive discussion on how to avoid secondhand smoke.	Bowl filled with short statements on how to avoid secondhand smoke/what to say/what to do. See Appendix for a list of potential statements.	Place bowl on table. Have athlete(s) pick up a note to read to group or volunteer can read.	<ul style="list-style-type: none"> • Best with 2 or more athletes. Ask for a suggestion on how to avoid the smoke or what to say to someone. • Discuss the statements with the athlete/group. • Get their input and recommendations.

References

Sun Safety:

7. World Health Organization Bulletin: The current public health message on UV exposure overlooks many health benefits <https://www.who.int/bulletin/volumes/85/5/06-035089/en/>
8. World Health Organization - Skin Cancers: https://www.who.int/uv/health/uv_health2/en/index1.html
9. World Health Organization - Ultraviolet Radiation: www.who.int/topics/ultraviolet_radiation/en/
10. World Health Organization - In defense of the sun: an estimate of changes in mortality rates in the United States if mean serum 25-hydroxyvitamin D levels were raised to 45 ng/mL by solar ultraviolet-B irradiance? *Dermatoendocrinol.* 2009;1(4): 207-214. www.ncbi.nlm.nih.gov/pmc/articles/PMC2835876
11. World Health Organization - Sun protection: Enjoy the sun, but enjoy it safely: https://www.who.int/uv/sun_protection/en/
12. Vitamin D for Health: A Global Perspective; Hossein-nezhad, Arash et al. *Mayo Clinic Proceedings* Volume 88 Issue 7 , www.ncbi.nlm.nih.gov/pubmed/23790560

CHAPTER 5

Education Stations

APPENDIX

Nutrition Education Station

1. Foods that Make Me Healthy Guide (aka food and beverage replacements)
2. Bone Health Education Station – [Comparison of Milk Table](#)
3. Hydration Education Station – Re-Think Your Drink Poster
 - a. Link to the Re-Think Your Drink Card Labels:
https://www.dropbox.com/s/xdobejur0lem8n4/PPPDS_RYDDrinkLabelCardsL1-1B.pdf?dl=0
4. Handwashing Education Station – Photo prompts
5. Gross Mouth – Photo Prompts
6. Tobacco Avoidance and Cessation Education Station – “What to Say”

Compare Milk and Milk Replacements

	Calories	Protein gm	Fat gm	Sat fat g	Carb g	Vitamin D IU	Calcium mg	Sodium mg	Added sugar
Almond Milk Sweetened	60	1	2.5	0	8	100	300	150	8 gms
Almond Milk Unsweetened	40	1	2.5	0	0	100	300	160	0
Coconut Milk So Delicious	80	1	5	5	0	0	450	30	0
Cow's Milk skim	86	8	0.4	0.3	12	100	300	127	0
Cow's Milk 1%	100	8	2.4	1.5	12	100	300	100	0
Cow's Milk 2%	120	8	5	3.1	11.4	100	300	100	0
Cow's Fairlife skim	80	13	0	0	6	100	400	120	0
Cow's Fairlife 2%	120	13	4.5	3	6	100	400	120	0
Cow's Fairlife chocolate	200	13	3	4	13	100	400	400	12
Cow's Milk whole	150	8	8	5	13	100	300	100	0
Cow's Milk flavored 1%	190	10	3	1.5	32	100	300	230	20
Goats Milk 2%	100	8	2.5	1.5	11	0	300	115	0
Goats Milk whole	140	8	7	4	11	0	300	115	0
Hemp Milk	160	4	5	0.5	24	0	500	135	24
Muscle Milk	160	15	8	3.3	6.5	72	300	150	16
Oat Milk	80	9	0	0	12-19	0	300	125	12-19
Rice Milk	120	1	2	0	25	100	300	90	12-25
Ripple Milk pea powder veg oil	80	8	45	.5	0	120	450	100	0
8 th Continent Soy Original	80	8	2.5	0	0	100	300	95	0
Soy Milk Sweetened	90	7	1.5	0.5	13	100	300	190	13
Soy Pacific Ultra Vanilla	130	10	4	0.5	0	100	500	150	0-8
Soy Silk Plain	100	8	5	0.5	8	120	300	120	8
Orange Juice with Ca & D	110	2	0	0	26	100	350	0	0
Ripple	100	8	5	.5	6	100	450	120	0
Camel	100	3	8	0	6	600	300	144	0

USDA National Nutrient Database for Standard Reference, Release 24 (2011) www.ars.usda.gov/Services/docs.htm?docid=8964



Milk Alternatives: Are They Really Better for You, or Is It Hype? 2018

By Maureen Callahan, RD and lead author of the Health.com diet book review series.

Supermarket are jammed with all manner of “milk” selections that don’t come from the dairy down the road, but from plant sources like nuts, soy and grains. Rapidly stealing cows’ milk customers, non-dairy beverages are popular for all kinds of reasons, from environmental concerns to animal well-being to lactose intolerance. But what do these milks knock-offs taste like? And are they good-for-you? Looking at the big picture, it’s a mix of pros and cons. On the plus side are low levels of artery-clogging saturated fat, zero cholesterol and convenient packaging. The cons: Sugar content is often high and protein levels, except for soy milk, are not impressive. Drink them if you like the taste but be sure to get the 24 grams of protein that 3 cups of cow’s milk would provide, from other dietary sources.

Almond Milk: The “Miss Congeniality” of non-dairy alternatives, almond milk glows with a nutrient-rich almond halo. After all, an ounce of almonds (23 nuts) sports a healthy six grams of protein, lots of Vitamin E and small amounts of minerals, like magnesium and calcium. The hitch: A cup of almond milk contains roughly four almonds, according to Nutrition Action Health Letter, barely enough to contribute much of that good-for-your almond nutrition. One cup of this milk (mostly water and sweeteners) delivers just one gram of protein, unless you buy one of the newer protein-fortified varieties. All alternative milks have added sugars except for the unsweetened varieties. This beverage has a faint almond flavor, mouthfeel like skim milk. Calories per cup: 30-120; 1-gram protein, 1-23 grams carb (0-22 grams sugars), 3 grams fat

Hemp Milk: This light beige drink is winning over converts at a rapid clip, mostly due to its thicker, creamier texture. The nutrition claim to fame for these seeds is that they're a rich source of omega 3 fats, the fats that are heart healthy. Of the 5-6 grams of fat in a cup of hemp milk, only half a gram is saturated. Protein is just two grams per cup. Hemp milk has a mildly nutty with a subtle sweetness. Calories per cup: 70-190; 2 grams protein, 1-35 grams carb (6-23 grams sugars), 6 grams fat

Coconut Milk: If you're expecting the bold flavor of canned coconut milk, this beverage is sure to disappoint. These drinks have is plenty of saturated fat, as much as whole milk. That probably explains their popularity as coffee creamers and cereal toppers since saturated fat delivers a richer mouthfeel. The jury is in on the touted health benefits of coconut oil and fats. Despite what you hear about coconut being a healthy fat, the American Heart Association recommends going easy on all saturated fats, including coconut. Coconut milk, which is low in protein like other alternatives, sports the lowest carb levels of alternative milks with 5 or 6 grams per cup. Chocolate flavored varieties have 10 grams (a little over two teaspoons) of sugar. Not very sweet and the coconut flavor is barely detectable. Calories per cup: 50-100; 0-1 gram protein, 1-12 grams carb, 1-10 grams sugars, 5 grams fat

Rice Milk: Made by blending cooked brown rice with water, this bright white drink looks most like cow's milk in the glass. But like other alternatives, it delivers a measly gram or two of protein per cup, compared to the 8 grams found in dairy milk. On the minus side for diabetics and anyone watching their sugar intake, it's also the richest in carbs of non-dairy beverages with unsweetened varieties often having 10 grams of carbs (instead of the usual one or two grams) and flavored varieties going as high as 34 grams (8 teaspoons sugar.) Who benefits? Anyone with a nut allergy or people looking for a gluten-free alternative. Most "watery" of the alternative milks, this one is also the sweetest tasting. Calories per cup: 70-160; 1-2 grams protein, 11-34 grams carb (1-28 grams sugars), 3 grams fat

Soy Milk: The best source of protein among the "milk" alternatives, soy milk is a close match to 2% cow's milk when it comes to nutrition. It carries about 7 grams of protein; cow's milk has 8 grams. It's moderate in fat, about 4 grams per cup, compared to 2% milk's 5 grams. Where they differ? Most of soymilk's fat is the unsaturated heart-healthy variety while most of cow's milk's fat is saturated. So, if you're looking for a non-dairy beverage to replace milk's nutrition and improve on its fat profile, this is the one to buy. Light (half the fat) and fat-free versions are available. Chocolate-flavored soy beverages have the most sugar (21 g), followed by strawberry (15 g), vanilla (8 g) and original (5 to 8 g). Original, unflavored soy milk has 80 to 100 calories per cup, depending on brand; unsweetened versions have 60 to 80 calories. While most brands are fortified with vitamins and minerals, some aren't, so read labels. Most soybeans grown today are genetically modified, look for organic products if you want to sip "non-GMO." Added sugars and flavors don't mask the mildly "beany" flavor. Calories per cup: 90-130; 6-8 grams protein, 7-14 grams carb (6-11 grams sugar), 4 grams fat

























How long do these alternative milks last once opened? Like cow's milk, most alternative milks are ultra-pasteurized (exposed to high heat for short periods of time) to extend shelf-life. Once opened, store them in the refrigerator and use them up in 7 to 10 days.

How can you tell if almond, rice or coconut "milk" is spoiled? Just like with dairy products, alternative milks will curdle, develop funky aromas and go through changes in color and texture that signal spoilage.

Do alternative milks match up to cow's milk when it comes to calcium and vitamin D? That depends. Alternatives are fortified with anywhere from 10 to 45 percent of daily calcium requirements. But the type of calcium used is key. If it's calcium carbonate, the body takes it in easily. If it's tricalcium phosphate, don't expect to absorb as much due to lower bioavailability. Vitamin D is a different story. Cow's milk is fortified with vitamin D3; alternatives contain vitamin D2, usually about 25 to 30 percent of the daily requirement.

What's a good benchmark for healthy amounts of added sugar in these milks? Unsweetened alternative milks, averaging 0 to 2 grams of sugar per cup, aren't a problem. And anything that keeps in line with cow's milk, which has 12 grams of lactose per cup, is fine. Lactose helps your body absorb calcium, but other added sugars do not. And if you step into flavored territory and sugar levels skyrocket. A cup of chocolate flavored almond or hemp seed milk packs a whopping 22 to 23 grams or almost 6 teaspoons of sugar. Chocolate-flavored rice milk can have as much as 34 grams of sugar. For reference, the American Heart Association recommends a daily limit of 6 teaspoons (24 grams) of added sugar calories per day for women and 9 teaspoons (36 grams) for men.

Choose health. Drink water.

Drink, Calories and Container Size (fluid ounces)	Teaspoons of Sugar per Container Size	Minutes of Brisk Walking to Burn Off the Drink (walking at 3.5 mph)
 Soda 227 calories 20 fl. oz.	14 tsp 	49 min. 
 Sports Drink 125 calories 20 fl. oz.	9 tsp 	27 min. 
 Energy Drink 240 calories 16 fl. oz.	15 tsp 	52 min. 
 Juice Drink 305 calories 20 fl. oz.	17 tsp 	66 min. 
 Fruit-flavored Soda 165 calories 12.5 fl. oz.	11 tsp 	36 min. 
 Vitamin-added Water 125 calories 20 fl. oz.	8 tsp 	27 min. 
 Sweetened Tea 213 calories 20 fl. oz.	14 tsp 	46 min. 
 Water 0 calories 20 fl. oz.	0 tsp 	0 min. 

Note: Walking times are based on the average calorie expenditure for a 154-pound individual walking at 3.5 mph (280 calories/hour). Calories burned per hour will be higher for persons who weigh more than 154 pounds and lower for persons who weigh less. Teaspoons of sugar are rounded to the nearest whole number. All walking times are rounded up to the next whole number.

United States Department of Health and Human Services, U.S. Department of Agriculture. *Dietary Guidelines for Americans, 2005*, Table 4, Calories/Hour Expended in Common Physical Activities. <http://www.health.gov/dietaryguidelines/dga2005/document/html/chapter3.htm>. Accessed May 15, 2012.



This material was produced by the California Department of Public Health's Nutrition Education and Obesity Prevention Branch with funding from USDA SNAP-Ed, known in California as CalFresh. These institutions are equal opportunity providers and employers. CalFresh provides assistance to low-income households and can help buy nutritious food for better health. For CalFresh information, call 1-877-847-3663. For important nutrition information, visit www.CaChampionsForChange.net.



Handwashing Photo Prompts

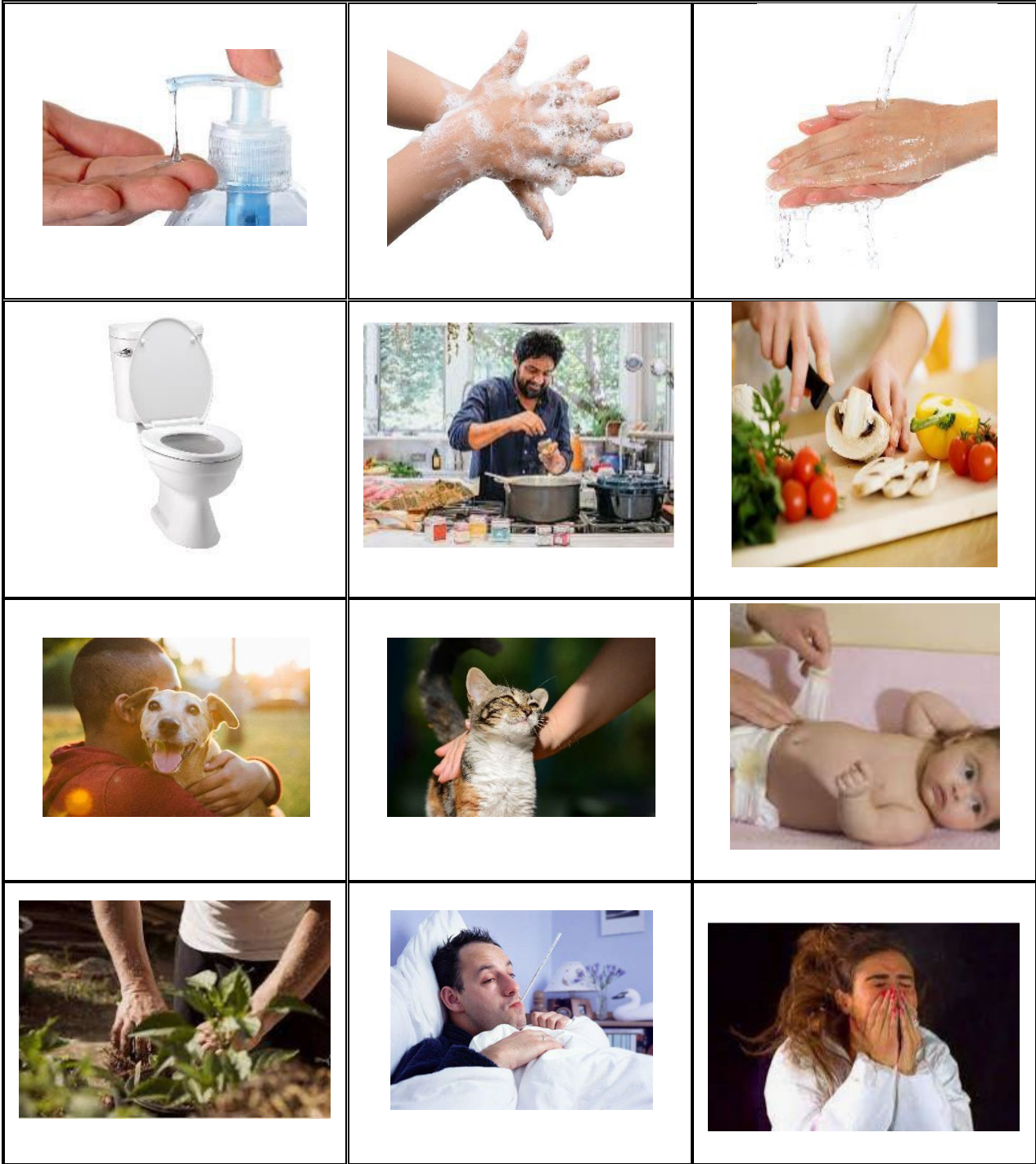

Tobacco What to Say Statements

<p>Please don't smoke in my space</p>	<p>I am an athlete I need clean air</p>	<p>Let's go outside for fresh air</p>
<p>I have a favor to ask, please don't smoke around me</p>	<p>I know it is hard for you not to smoke, but it is important for me that you don't smoke in the house.</p>	<p>Can you help me find a place where there is not smoke?</p>
<p>Being the best at my sport is important to me, please don't smoke around me.</p>	<p>It makes me happy when you don't smoke.</p>	<p>What can I do to help you to stop smoking?</p>
<p>I get asthma from smoke.</p>	<p>Smoke makes my eyes burn.</p>	<p>My grandfather died from smoking.</p>
<p>I heard someone say, "I miss my other lung".</p>	<p>I'm allergic to smoke.</p>	<p>Could you smoke outside please?</p>

Gross Mouth Photo Prompts

Impact of tobacco



Effects of chewing tobacco on teeth and gums



Effects of tobacco on staining of teeth

Before It Reaches Your Lungs

E-cigarette vapor can impact your health

New research shows similar oral cancer-linked impacts on gum cells from e-cigarette vapor and cigarette smoke.

E-cigarette use is linked to increased rates of tooth decay and gum disease.

Emerging research shows that in your mouth, e-cigarettes can cause negative health effects very similar to those caused by traditional cigarette smoke.

Is it worth the risk?



**NC ORAL HEALTH
COLLABORATIVE**

VAPING Tobacco is as dangerous as smoking and chewing tobacco



Special Olympics **Health Promotion**

**Chapter Six:
Check-**

Background Information

The Check-Out station is the athlete's last stop before leaving the venue. This is the station where all screening results are explained, brief education on athlete's chosen health topic is provided, and referrals are made.

What happens during Check- Out?

- Greet the athlete and review the HAS form, complete missing data, check referral boxes, for screening result(s) that reach the referral threshold(s).
- Transfer data to the Athlete Health Report.
- Explain results to the athlete, using the reference guides.
- Make a referral, if needed.
- Help the athlete identify one behavior to change.
- Recap and thank the athlete, provide an incentive item to the athlete.

Volunteer Recommendations

The Check-Out station requires experienced, licensed, healthcare professionals (e.g., dietitians, nurses, physicians, physician assistants) or senior level students in those areas. The volunteers assigned to Check-Out must be familiar with the HP screening exams, referral protocols, Health Habits Interview, Choose to Change card topics. Volunteers with clinical backgrounds will have the skills needed to synthesize this information, address the referral needs and help the athlete select a health behavior goal along and suggestions on how to achieve it. Volunteers need formal training to ensure they have the skills necessary for this role.

BEST PRACTICE: A general volunteer is needed to escort athletes back to clinical screening stations they may have missed. If time allows and only if it doesn't create a back-up, the Check-Out volunteer may complete unanswered questions on the Health Habits Interview questions are missing.

Station Layout – Check-Out

The Check-Out station layout needs to be well planned and organized. The one-on-one conversation and form review between the volunteer and each athlete, plus easy access to materials requires that the table be kept tidy. (appendix)

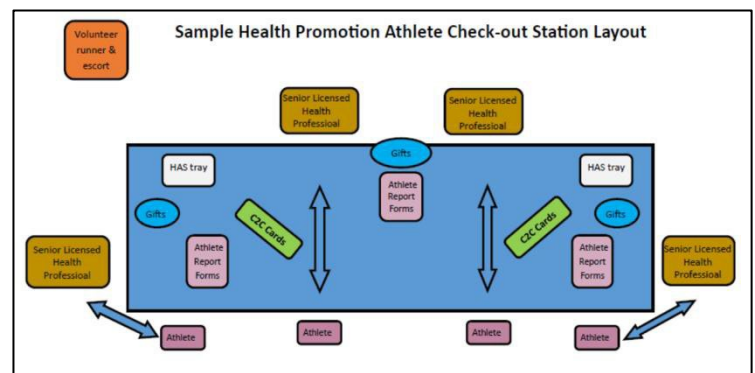

Equipment and Tools

For Distribution to the Athlete

- Athlete Health Report form -- printed in color (one per athlete).
 - *It's recommended that programs type the location, date of event and contact information on the form before printing copies to save time.*
- Choose to Change cards for stations offered at the event.
- Fit 5 Tracking Tool if fitness programming is offered through the local Program (see appendix)
- Educational incentives and thank you gifts, if available.



For the Station Volunteer

Each volunteer at Check-Out will need a small three ring binder or folder with the following documents (printed in color) and in protected in plastic sleeves. These are the reference materials needed to ensure volunteers properly complete the Athlete Health Report form and providing the necessary referrals.



- Copy of the [HAS form](#), for reference
- [Athlete Health Report Screener Reference Tool](#)
- Screening Reference Guides for:



- [Body Mass Index](#)
- [Waist Height Ratio](#)
- [Bone Mineral Density](#)
- [Blood Pressure](#)

- [BMI Chart for Adults](#)
- [Pediatic Growth Charts for girls and boys](#)
- BMI wheels for children and adults (or ensure volunteers have BMI app on their phones)

Additional Equipment and Supplies

- A table and chairs for both athletes and volunteers.
- Pens (and clipboards, if not using electronic tablets).
- Square or rectangle plastic baskets to collect HAS forms (if not using tablets), as well as to organize Choose to Change cards and other materials to keep the table neat and organized.

Check-Out Station Supplies and Materials

The collage displays various materials and equipment. At the top, four categories are labeled: HAS Forms, Athlete Health Report, Screener Tool AHR, and Choose to Change. Below these are images of the respective documents. In the bottom left, 'Reference Guides' are shown. In the center, there are images of a smartphone and a tablet, both displaying the CDC BMI App, with QR codes for downloading them. To the right, there are several colorful plastic baskets and a row of colorful three-ring binders.

Protocol - Check-Out Actions and Referrals

The volunteers are Check-Out should:

1. Greet the athlete and introduce themselves.
2. Review the HAS form (on paper or on tablet) and ask themselves the following questions:
 - *Is it complete?*
 - *Do the values look appropriate and follow protocols and not have errors such as using centimeters, not meters or having a mix metric and English measurements, instead of a consistent measurement*
 - *Was a clinical screening missed?*
 - *Is a referral necessary? Is it urgent for Blood Pressure? and*
 - *Is the Health Habits Interview complete?*
3. Assess screening results and transfer the screening data onto the Athlete Health Report. Indicate if referrals are needed on the HAS form.
 - a. When making referrals and completing the Athlete Health Report, follow the referral protocols for Body Mass Index, Waist Height Ratio, Bone Mineral Density and Blood Pressure, as shown on the Health Promotion Screening Reference Guides.
4. Review and discuss the screening results and Athlete Health Report with the athlete.
 - a. Athletes are given their Athlete Health Report form to share with their guardian, parents, and health care provider.
 - b. The conversation acknowledges the athlete's strengths such as eating well, participation in Special Olympics sports, coming to Health Promotion and so on.
5. Invite the athlete to select 1-2 **Choose to Change** cards based on their interests and screening results.
 - a. The volunteer will review the bulleted suggestions on the selected card to reinforce health behaviors the athlete may choose to help meet their chosen goal.
 - b. If the athlete doesn't want to set a personal goal, encourage them to select a Choose to Change card to share with family or friends and to empower the athlete to be a health leader.
6. If available, give the athletes the educational takeaways or incentive item as a thank you for their participation and as reminder of the key messages they learned in Health Promotion.
7. Local referrals HP protocols require medical referrals for athletes with high risk body mass index, high waist height ratio, bone density and blood pressure screening results. Athletes should be made aware of community-based services (CBS) focused on both prevention and/or supporting improvement of chronic disease conditions and other social determinants of health. Ideally, the Program staff, Clinical Director(s) and/or a partnering organization will maintain a list of local municipal and non-profit services that would benefit the athletes. The list would include the Program sponsored activities such as Fitness programming and Healthy Community contacts. Programs may choose to work with local or regional Information and Referral Programs and agencies that maintain current listings of services to address the full range of social determinants of health. International programs are encouraged to identify information and referral opportunities for athletes in their local communities.



IMPORTANT CONSIDERATION:

Prior to the event, the HP CD should check in with their Healthy Athletes Coordinator to understand the Program's post-event referral and follow-up plan.

Check Out Challenges

Issue	Correction
Clinical screening station missed	Ask athlete to return to the station for the screening, a volunteer should accompany athlete to facilitate the screening.
Athlete refuses to complete screening	Continue with Check-Out
A screening test (i.e., bone mineral density) was not conducted at the event	Mark an X or put “Not Screened” on the Athlete Health Report
Screening results look questionable (i.e., Blood Pressure numbers just 2 digits, BMI or Waist Height Ratio calculation does not look correct for athlete, a + or – sign is not recorded for each BMD T-score)	Discuss with lead Clinical Director and either the Check-Out volunteer or the Clinical Director should confirm the protocol and values with the screening station volunteers to ensure issues are not being repeated with all athletes and data is being properly entered.
Health Habits Survey not complete	If athletes are waiting to be checked-out, ask the athlete to return to the Health Habits station for the screening a volunteer should accompany athlete to facilitate the screening. Volunteer should complete at Check-Out station if time permits. The athlete may decline completing the interview.



Check-Out Station Los Angeles CA 2018



Check-Out Station Winter World Games Austria 2017

CHAPTER 6

Check-Out

APPENDIX

1. For Station Volunteer

a. [Athlete Health Report Screener Reference Tool](#)

b. Screening Reference Guides for

- [Body Mass Index](#)
- [Waist Height Ratio](#)
- [Bone Mineral Density](#)
- [Blood Pressure](#)

c. [BMI Chart for Adults](#)

d. Pediatric Growth Charts for [girls](#) and [boys](#) (appendix)

e. BMI wheels for children and adult (see *CHAPTER 2 - APPENDIX 5: Health Promotion Equipment and Supplies List February 2022*)

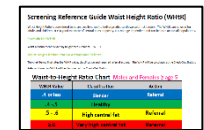
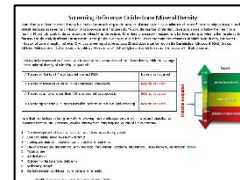
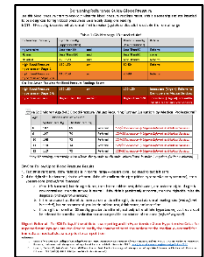
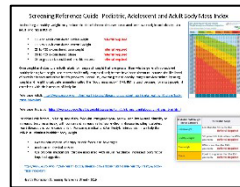

2. For Individual Athletes

a. [Athlete Health Report form](#) (front and back)

b. [Choose to Change Cards](#) (at bottom of web page)

c. [Fit 5 Tracking Tool](#) (if program choose to use)

3. [Suggested Layout](#)

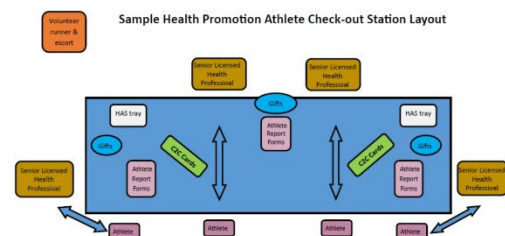





Special Olympics





Health Promotion





Athlete Health Report Screener's Tool 2022

Today we measured 4 things that tell you about your health. We recommend that you share these results with your doctor.

- **Body Mass Index or BMI** tells how much body fat you have and helps predict risk of heart disease, diabetes and high blood pressure.
- **Bone Mineral Density or BMD** tells how strong your bones are and helps predict risk of future fracture.
- **Blood Pressure or BP** tells the amount of force pushing against your artery walls when your heart beats and rests, and it helps predict risk of stroke.
- **Weight to Height Ratio or WHtR** is a universal screening tool to measure abdominal girth and fat. It is not age, gender or ethnicity dependent.

Body Mass Index			
<18.5 – Adults <5th - Youth	18.5-24.9: Adults 5th – 84th: Youth	25.0-29.9: Adults 85th – 94th: Youth	>30: Adult >95th: Youth
underweight  Referral	healthy 	overweight  Referral	obese  Referral

Bone Mineral Density			
< -2.5	-2.4 to -1.0	-0.9 to +3.4	>+3.5
osteoporosis  Referral	osteopenia  Referral	healthy 	too high  Referral

Blood Pressure				
<90/60	90/60 → 139/89	120/80 → 159/99	160/100 → 179/109	>180/110
Hypotension  Referral	Healthy 	High BP Stage 2a  Referral	Very High BP Stage 2b  Retest. If still high, urgent referral to Medical Services	Dangerous Stages 3 & 4  Retest. If still high, urgent referral to ER

Refer to pediatric BP referral chart for cutoffs for youth under ≥ 18.

Waist-to-Height Ratio Chart Males and Females ≥ age 5

WHtR Value	Classification	Action
.4 or less	Slender	Referral
.4 -.5	Healthy	
.5 - .6	High central fat	Referral
≥.6	Very high central fat	Referral

Special Olympics

Health Promotion

Health Promotion Athlete Health Report Referral Information

Recently _____ participated in a Health Promotion event and participated in **four health screenings including BMI, waist to height ratio (WHtR), bone density and blood pressure**. See results on the reverse side of this report. If none of the athlete's screening results are checked, they are in normal ranges. Results may be used as baseline for athletes who may not have been screened earlier. The checked results suggest the need for follow-up involving:

Recommendations for all athletes

- Work with a registered dietitian/nutritionist or physician for advice on a nutrient rich diet that balances calories with need.
- [Steps to maintain healthy vitamin D levels \(40-60 ng/ml\).](#)
- [Provide instruction on regular aerobic, weight-bearing and strength building activities.](#)
- If the athlete uses tobacco, provide cessation support.
- Advise no or minimal alcohol use.

_____ **Body Mass Index: underweight, overweight or obese.** BMI assess a person's weight in proportion to their height. A high BMI shows elevated risk for high blood pressure, diabetes, heart disease, stroke, liver disease and breathing problems. **If checked**, we recommend follow-up with the athlete's primary provider

_____ **Waist to Height Ratio- WHtR** measures the distribution of body fat. Higher values (**WHtR >0.5**) show elevated risk of CVD, type 2 diabetes, hypertension, stroke and other chronic diseases. WHtR is a measure of the distribution of body fat. As the WHtR ratio rises above .5 it correlates with a progressively higher proportion of visceral fat which correlates with elevated risk of non-communicable diseases including metabolic syndrome, CVD, type 2 diabetes, hypertension, stroke, atherosclerosis, non-alcoholic fatty liver disease, some cancers and other metabolic based conditions. The ratio applies to people ages 5 and older, independent of age, gender and ethnicity. **If checked** follow-up with the athlete's primary provider or a dietitian is recommended for further assessment, nutrition and exercise counseling. Follow recommendations for all athletes above.

_____ or a dietitian for further assessment, nutrition and exercise counseling. Follow recommendations for all athletes

_____ **Bone Mineral Density: low T-score.** The BMD T-score compares bone density to that of a healthy 30-year-old. The T-score is a predictor of future fracture. **If checked**, we recommend that you address lifestyle changes with the athlete; consider DXA and 25(OH) D test, assess medications for negative bone health side effects and work with a nutritionist or physician for advice on a balanced diet with bone building nutrients. Follow recommendations for all athletes above.

_____ **Blood Pressure: high or low.** Lifestyle changes shown to lower blood pressure, protect heart health, and carry other health benefits. Low blood pressure treatment is based on underlying cause. **If checked**, and athlete is not being treated for high (or low) BP, we recommend athlete's BP be tracked over the next few weeks. Results should be reviewed by the health care provider for possible intervention. Follow recommendations for all athletes above.

We hope to work together to improve the health of all athletes who participate in Special Olympics. If you have any questions, please feel free to contact the Health Promotion Clinical Director or Special Olympics staff.

CHAPTER 6 - APPENDIX 2: Screening Reference Guides and Volunteer Check-Out Binder

The following documents should be put into a binder for each Check-Out station for them to reference. You can access the screening guides and Body Mass Index Charts in Chapter 3 appendix.

- a. Screening Reference Guides for
 - [Body Mass Index](#)
 - [Waist Height Ratio](#)
 - [Bone Mineral Density](#)
 - [Blood Pressure](#)
 -
- b. [BMI Chart for Adults](#)
- c. Pediatric Growth Charts for [girls](#) and [boys](#)
- d. BMI wheels

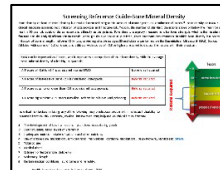
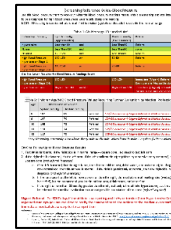
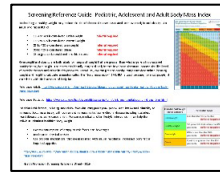

All the screening guides and materials are also available on the Health Promotion Resources website:
<https://resources.specialolympics.org/health/health-promotion>



Athlete Health Report

Today we measured 4 things that tell you about your health. Please discuss results with your doctor.



Body Mass Index tells how heavy you are compared to height and helps predict risk of cardiovascular disease (CVD), diabetes and high blood pressure.



Bone Mineral Density tells how strong your bones are and helps predict risk of future fracture.



Blood Pressure tells the amount of force pushing against your artery walls when your heart beats and rests, and it helps predict risk of stroke.



Waist to Height Ratio- WHtR measures the distribution of body fat. Higher values of WHtR $>.5$ indicate elevated risk of CVD, type 2 diabetes, hypertension, stroke and other chronic diseases.

Body Mass Index or BMI

<18.5 – Adults <5 th – Youth	18.5-24.9 Adults and 5 th – 84 th Youth	25.0-29 Adults 85 th – 94 th Youth	>30 Adult >95 th Youth
underweight Referral	healthy 	overweight Referral	obese Referral

Bone Mineral Density or BMD

< -2.5	-2.4 to -1.0	-0.9 to +3.4	>+3.5
Osteoporosis Urgent Referral	Osteopenia Referral	healthy 	Too high Referral

Blood Pressure or BP Refer to separate referral chart for ages 18 and lower

<90/60	90/60 to 139/89	120/80 to 159/99	160/100 to 179/109	>180/110
Hypotension Referral	Healthy 	High BP age Elevated to Stage 2a Referral	Very High BP Stage 2b Retest. If still high, urgent Medical Services referral	Dangerous Stage 3 & 4 Retest. If still high, urgent ER referral

Waist-to-Height Ratio Chart Males and Females \geq age 5

WHtR Value	Classification	Action
.4 or less	Slender	Referral
.4 - .5	Healthy	
.5 - .6	High central fat	Referral
$\geq .6$	Very high central fat	Referral

Athletes can measure at home. Athletes are encouraged to use a length of string as long as their height, fold it in half, wrap around their waist just above their navel or the iliac crest. If the string ends don't touch, the athlete's waist is more than half their height, and this indicates a ratio above .5. See reverse side for recommendations. See [M. Ashwell Shape Chart](#) for additional information.

Health Promotion Athlete Health Report

Recently _____ participated in a Health Promotion event and participated in **four health screenings including BMI, waist to height ratio (WHtR), bone density and blood pressure**. See results on the reverse side of this report. If none of the athlete's screening results are checked, they are in normal ranges. Results may be used as baseline for athletes who may not have been screened earlier. The checked results suggest the need for follow-up involving:

Recommendations for all athletes

- Work with a registered dietitian/nutritionist or physician for advice on a nutrient rich diet that balances calories with need.
- [Steps to maintain healthy vitamin D levels \(40-60 ng/ml\)](#).
- [Provide instruction on regular aerobic, weight-bearing and strength building activities](#).
- If the athlete uses tobacco, provide cessation support.
- Advise no or minimal alcohol use.

_____ **Body Mass Index: underweight, overweight or obese.** BMI assess a person's weight in proportion to their height. A high BMI shows elevated risk for high blood pressure, diabetes, heart disease, stroke, liver disease and breathing problems. **If checked**, we recommend follow-up with the athlete's primary provider or a registered dietitian for further assessment, nutrition and exercise counseling. Follow recommendations for athletes listed above.

_____ **Waist to Height Ratio (WHtR)** measures the distribution of body fat. Higher values (**WHtR >0.5**) show elevated risk of CVD, type 2 diabetes, hypertension, stroke and other chronic diseases. WHtR is a measure of the distribution of body fat. As the WHtR ratio rises above .5 it correlates with a progressively higher proportion of visceral fat which correlates with elevated risk of non-communicable diseases. The ratio applies to people ages 5 and older, independent of age, gender and ethnicity. **If checked** follow-up with athlete's primary provider or a registered dietitian for further assessment, nutrition and exercise counseling. Follow recommendations for athletes listed above.

_____ **Bone Mineral Density: low T-score.** The BMD T-score compares bone density to that of a healthy 30-year-old. The T-score is a predictor of future fracture. **If checked**, we recommend that you address lifestyle changes with the athlete; consider DXA and 25(OH) D test, assess medications for negative bone health side effects and work with a nutritionist or physician for advice on a balanced diet with bone building nutrients. Follow recommendations for all athletes listed above.

_____ **Blood Pressure: high or low.** Lifestyle changes shown to lower blood pressure, protect heart health, and carry other health benefits. Low blood pressure treatment is based on underlying cause. **If checked** and athlete is not being treated for high (or low) BP, we recommend athlete's BP be tracked over the next few weeks. Results should be reviewed by the health care provider for possible intervention. Follow recommendations for athletes listed above.

We hope to work with you to improve the health of all athletes who participate in Special Olympics. If you have any [questions](#) please feel free to contact the Health Promotion Clinical Director or Special Olympics staff.

Name Clinical Director _____ email _____ phone _____

Name: Special Olympics Health Manager email _____ phone _____

CHAPTER 6 - APPENDIX Choose to Change Cards

The [Choose to Change](#) series of health education cards is designed to be shared with athletes at the Check-Out station. The cards are tools to help athletes set health behavior goals and take more control of their health and well-being. The topics address several of the [World Health Organization chronic disease prevention goals](#) and represent global public health priorities.

- Offer each athlete no more than 1-2 cards, to help focus on a topic meaningful to the athlete. Review the athletes’ education topic choice and recommended behavior(s) for the topic.
- Offer *Choose to Change* cards that match the venue topics. For example, if your venue does not include a tobacco avoidance education station, don’t include that card in what is offered at Check-Out.
- *Choose to Change* cards are color coded, saved as PDF files, translated into a variety of languages and available on the [Health Promotion Resources](#) web page at end of page. To print the cards, go to [web link](#). The PDF files are formatted to print four cards per page. Print the cards on bright white card stock using colored ink, for the best contrast, to make it easier for the athletes to read.
- The images on the *Choose to Change* cards are intended to be globally relevant. Cards are translated into several different languages. Please let us know if you want to translate the written words or change photos to better reflect images and actions that best fit your region.



Make Health a Part of Your Training!



EXERCISE 5 days a week
 You can become a better athlete by enjoying physical activity outside your sports practice. There are many ways to be physically active and improve your:

- Endurance
- Strength
- Flexibility
- Balance



EAT 5 total fruits and vegetables per day
 Eating right is important for your health and for your sport performance.
 Eating right can be easy as there are a lot of delicious, healthy choices and ways to include fruits and vegetables to your meals and snacks.



DRINK 5 water bottles (60oz/500mL) per day
 Drinking the right amount of water is important for your health and can also help your athletic performance.
 You lose water when you go to the bathroom, sweat, exercise, and even breathe. It is important to replace that.



Special Olympics Health Promotion logo is a registered trademark of Special Olympics. © 2015 Special Olympics. All rights reserved. Special Olympics is not responsible for the content of this placemat. All trademarks are the property of their respective owners.

Weekly Exercise, Nutrition and Hydration Tracking

Track your Fit 5 progress!

	SUNDAY	MONDAY	TUESDAY	WEDNESDAY	THURSDAY	FRIDAY	SATURDAY
Exercise Check box if you exercised today! Write in the number of minutes	<input type="checkbox"/> Minutes	<input type="checkbox"/> Minutes	<input type="checkbox"/> Minutes	<input type="checkbox"/> Minutes	<input type="checkbox"/> Minutes	<input type="checkbox"/> Minutes	<input type="checkbox"/> Minutes
Nutrition How many total fruits and vegetables?	●●●●●	●●●●●	●●●●●	●●●●●	●●●●●	●●●●●	●●●●●
Water How many bottles (16oz) of water did you drink?	○●●●○	○●●●○	○●●●○	○●●●○	○●●●○	○●●●○	○●●●○
Fill in the star if you reached your Fit 5 goal this week: Exercise ★ Nutrition ★ Water ★							

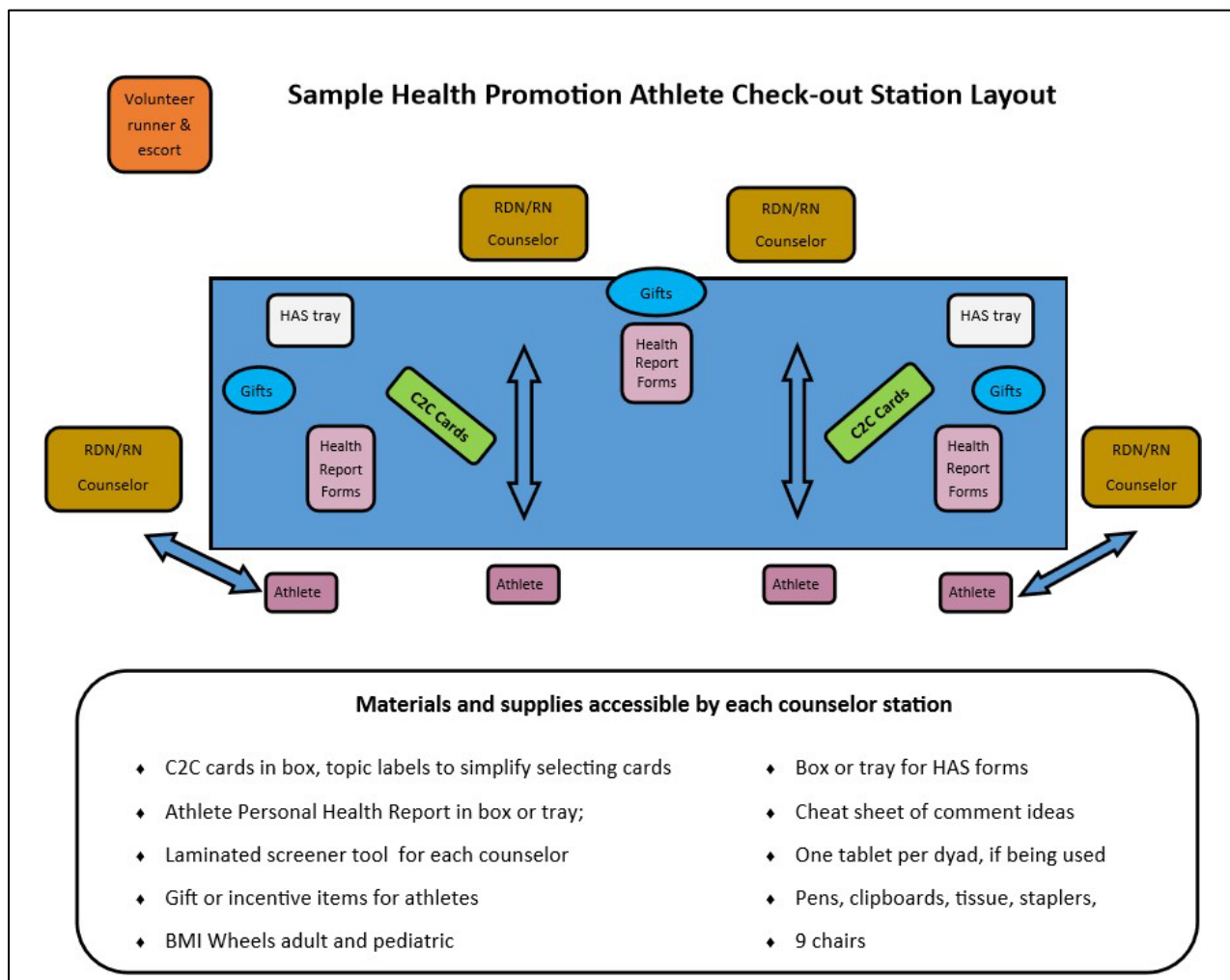



Special Olympics Health Promotion

**Chapter Seven:
Volunteer Management**

Background Information

Special Olympics Healthy Athletes could not have been created, nor would it exist today, without the time, energy, dedication and commitment of volunteers. Volunteers enable Special Olympics to offer Healthy Athletes services across the globe. Healthy Athletes' influence is evident with more than 120,000 healthcare professionals are now trained; free health screenings provided to nearly 1.7 million athletes. Healthy Athletes continues to grow each year with help from a global network of volunteers, in-kind donations and other financial support.

Volunteers from countries around the world help Special Olympics Healthy Athletes to grow with more and more athletes participating each year. As a Clinical Director, you are part of this incredibly important and significant public health initiative.

Volunteer management includes

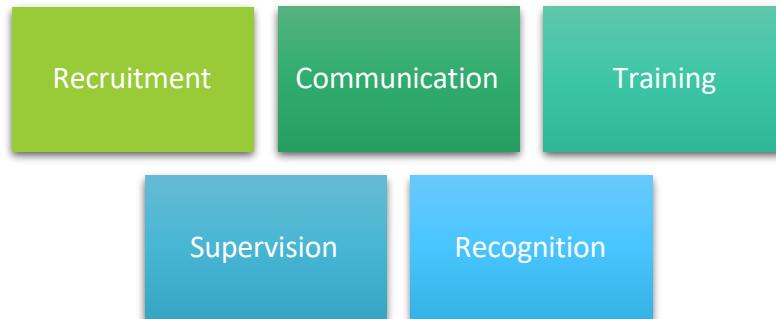

A positive volunteer experience will introduce people to Health Promotion who will enjoy their experience and continue to volunteer with Health Promotion.

Effective volunteer management includes these general tasks:

- Recruit and schedule volunteers to ensure that there are enough at each station for event to run smoothly
- Develop a plan to train and manage volunteers prior to and during the event
- Maintain a database of your volunteer contact information

Recruitment

Health Promotion Clinical Directors help the local Special Olympics Programs to recruit volunteers for their Health Promotion events. This involves finding people with the experience and background needed for the positions being filled. Discuss your volunteer recruitment, training and scheduling with your Program Healthy Athletes Coordinator, to clarify the number and types of volunteers you will need. Planned volunteer recruitment helps ensure that reliable, well-matched volunteers are in place prior to event. After assessing your needs, as outlined in earlier chapters, you will know the target numbers and types of volunteers where to recruit your volunteers. To streamline recruitment, create an engaging email or in person presentation that will consistently fit your recruitment needs.

Determining Volunteer Needs

As discussed in Chapter 2, several factors need to be considered when determining volunteer needs and assigning volunteers to stations for the event. These include expected athlete numbers, length of event, venue location and space. Below is initial guidance on the type and number of volunteers you may need for your event, based on a 1-2 day event with about 200 athletes coming through Health Promotion. You may need to scale up or down (or combine stations) depending on expected athlete attendance, venue space, and volunteer availability.

Guidance to determine volunteer needs based on a 1-2 day event with ~200 athletes attending NOTE: If the health Habits interview questions will be asked at the education stations, you will need more volunteers at those stations instead of the stand-alone interview station.

Station Title	Estimated # Stations	Estimated # of <u>TOTAL</u> Volunteers	Estimated # of <u>GENERAL</u> Volunteers	Estimated # of <u>CLINICAL</u> Volunteers	Volunteer Qualifications.
Clinical screening and interview stations					
BMI -height and weight	2	4	2	2	<p>For screening stations, clinical volunteers such as nurses, dietitians, physicians, health educators, public health professionals, etc., or students in these disciplines should be used.</p> <p>Additional general volunteers are helpful to assist with data entry but should not conduct the screening.</p> <p>* Red Cross volunteers.</p>
Waist Height Ratio	2	4	2	2	
Bone Mineral Density	2	4	2	2	
Blood Pressure*	3	3	0	3	
Health Habits	3	3	0	3	
Education stations					
Nutrition	1	2	0	2	<p>Education Stations: Use Clinical volunteers: nurses, dietitians, physicians, health educators, public health staff or students in these disciplines.</p>
Bone Health	1	2	0	2	
Hydration	1	1	0	1	
Sun Safety	1	2	0	2	
Physical Activity	1	1	0	1	Fitness professional or other clinical
Tobacco	1	1	1	0	General or clinical volunteers
Handwashing	1	1	1	0	General or clinical volunteers
Check-In and Check-out Station and Other Roles					
Check-In	2	2	2	0	General volunteers
Check-Out	3	3	0	3	Required: experienced senior clinical volunteers including nurses, dietitians, health educators, public health professionals, etc., or advanced students in these disciplines.
Escorts for athletes and teams. Scribes for screening stations	n/a	2	2	0	General volunteers

Who to Recruit

Recruit among universities, colleges, hospitals, public and tribal health agencies, health insurance and professional organizations. Think of people who can also encourage organization members to volunteer. Do not forget to include your personal network of friends, colleagues and family members.

Volunteer Registration

Work with your Program to become aware of volunteer registration protocols as each Program will have slightly different processes. If there isn't a process in place, you may want to use a Google Form, Qualtrics or some free software like those to facilitate registration so you know who you have coming in advance. You will want to collect information about individual's clinical background and experience, education levels (for clinical volunteers) in your registration process to help you assign volunteers to stations and ensure you have the proper mixture of volunteers for your event.

Volunteer Scheduling

Once your volunteers have registered and you know what days and hours are they available, you will need to determine to which station will clinical and/or general volunteers be assigned?



Use the [Health Promotion Volunteer Assignment Planning Template](#)

Station Name	Volunteer Type	Availability	Notes
Station 1 (Clinical)	Clinical	Available	
Station 2 (General)	General	Available	
Station 3 (Clinical)	Clinical	Available	
Station 4 (General)	General	Available	
Station 5 (Clinical)	Clinical	Available	
Station 6 (General)	General	Available	
Station 7 (Clinical)	Clinical	Available	
Station 8 (General)	General	Available	

Questions to Consider – Recruitment and Scheduling:

- What are the days and hours for the event? Will you have multiple shifts during the event?
- Which stations will you offer? Where will you situate them in the assigned area?
- How many clinical and general volunteers are needed for your event, based on venue, flow, time, etc.?
- Where will you recruit volunteers?
- What incentives can you offer volunteers?
- How many athletes are estimated to come to Healthy Athletes? Are there scheduled times when larger groups of athletes will come through the venue?
- Determine which stations need clinical volunteers, which need general volunteers and which stations need both?
- How will you keep lists and contact information of volunteers from year to year?

Communication

We recommend that you send a letter or email welcoming volunteers to the event and advising on their assigned station. Include information on the venue, dress code, dates and times of the volunteer assignment, as well as the time and location of training (whether it is occurring before or after). Also, share information including a map of the venue, parking, where the volunteer check-in will occur, and where shirts and credentials will be distributed. Finally, include information on the schedule and meals.

Keep in touch with the volunteers prior to the event to reinforce the importance of their volunteer role.

Training

Volunteer orientation and training helps ensure a safe and fulfilling experience for volunteers. Training helps to get volunteers excited about their participation in event and recognizes their importance to the athletes and your Program. Special Olympics offers materials for training volunteers, including the **Online Healthy Athletes General Volunteer Training Module** and short video presentations on Special Olympics that explain volunteers' roles and responsibilities. These optional materials can be shared with in the days leading up to the actual event. (see appendix for information on Online training)

Clinical Directors train volunteers to perform assigned tasks following the Health Promotion protocols. Local volunteer training is often done the same day as the event and completed an hour or two before the event begins. Some Clinical Directors can schedule volunteer training prior to the day of the event.

Volunteer orientation and training can be tracked and included in the [HP Venue Quality Assurance Checklist](#), used to document the activities at the Health Promotion event.

Ensure you or someone you assign, leads the general volunteer training according to a planned presentation. The on-line volunteer training module, coupled with your "day of event" training, provide valuable information to help volunteers succeed in their roles.

General Orientation:

General training begins with an introduction to the Special Olympics movement and the event. During the Orientation be sure to:

- Thank them for your time and dedication to the event and to people with intellectual disabilities.
- Give an overview of the purpose of Health Promotion and what stations and activities are offered at your event.
- Share a description of selected event demographics such as numbers of athletes, coaches, family members, volunteers.
- Discuss expectations for volunteers.
- Remind them of the overall campus including location of medical services.
- Reiterate the schedule for the event and process for breaks/meals, etc.
- Share points of contact and their roles. Include cell phone numbers for key staff at the event. Provide information on who to go to with questions or concerns arise.
- Provide tips on how to communicate and work with athletes. (see appendix **Working with our Athletes**)
- Give an overview of the other disciplines and activities that may be taking place at the same time, e.g., sporting events, Olympic Village, opening and closing ceremonies, and other planned activities.

BEST PRACTICE:

If you have multiple shifts of volunteers, have a plan to re-train new volunteers or ensure volunteers overlap for 30-60 minutes so the prior shift can train the next shift. If you have a shift train the other, plan to observe each station early during the second shift to ensure the cross-training was complete and new volunteers follow proper protocol.

Station-specific training:

It is important to provide volunteers the information they need to perform their specific duties at the station they have been assigned to. Suggested job-specific training components include:



- An overview of the stations including Check-In, Body Mass Index, waist height ratio, bone mineral density and blood pressure screening; Health Habits Interview, education posters and stations and Check-Out.
- Use the “*Things to Remember for This Station*” to help train volunteers on key activities and messages for each station.
- Follow the volunteer training skills activities for the screening and interview stations and have volunteers practice screening and/or delivery of key-messages from the station poster for their assigned stations (see appendices in Chapter 3 for Volunteer training tool and activity.)

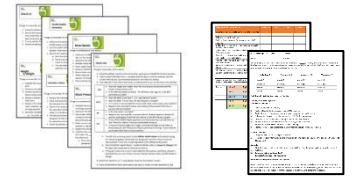

Questions to consider – Training:

- When will you train volunteers? Share training materials via email prior to the event? Will you train before the venue opens to athletes? Will you provide coaching to volunteers throughout the day, at their station?
- What will the outline of your volunteer training include?
- For station specific training, what job aids will you use and how will you organize these before your event?
- How will you train volunteers who don't attend your volunteer training session?
- **How will you conduct station specific training?**

Supervision:

Quality supervision of volunteers will help maximize the venue success. Once the volunteers complete orientation, training and assignments, they are ready to begin. The Clinical Director needs to ensure volunteers perform their roles satisfactorily based on established expectations and protocols. We encourage the following:

- Greet and welcome volunteers daily, preferably before they start their duties and confirm that the volunteer has current information on their assignment.
- Check in with volunteers periodically throughout the event to review how services are being conducted. Provide immediate feedback and coaching if issues are observed.
- This helps to help confirm the volunteer is comfortable and can adequately perform the assigned tasks. Address any concerns or issues from the previous day's work or interactions with other volunteers and athletes.
- Maintain records and daily notes as needed.
- Establish effective communication channels among your team.

Questions to consider - Supervision

- What steps can you take to assure that those who agree to volunteer show up and complete their shift?
- How will you coach volunteers if you see mistakes in how they are handling screening or education?
- Will you rotate volunteers or keep them at the same station for the entire event?

Recognition

Acknowledge the volunteers during and after the event with your thanks, volunteer certificates. For your student volunteers, follow-up with your university contact so students get credit and acknowledgment.

Questions to consider – Recognition:

- What incentive do individuals have to volunteer for the Health Promotion venue? For example, certificates of appreciation? Continuing education credits? T-Shirts? Acknowledgment in local newspaper, company newsletters, professional newsletters? Other gift items?
- How will you increase the likelihood that your volunteers will return to help with future events?

CHAPTER 7

Volunteer Management

APPENDIX

1. Volunteer Training Tool – Things to Remember for this Station
2. Volunteer Scheduler Template
3. Volunteer Training Guides and Practice Activities
4. Volunteer Training Outline



Things to remember at the Check-In station:

1. Greet the athlete warmly and see how their Games experience is going.
2. Record the necessary demographic information at the top of the HAS form. The most important information to be sure you have includes Athlete name, DOB or their age (at a minimum), gender, location and date of the event.
3. If using tablets, follow data entry instructions.
4. Thank the athlete and send them on to the next station (Height and Weight)



Things to remember for the Height and Weight station:

1. Validate the accuracy of the stadiometers and calibrate the scales at the start of the shift.
2. Welcome the athlete and explain what will be done.
3. Athlete should remove shoes and hats (and fanny packs or other heavy accessories) before measurement.
4. Measure athlete's weight and record to the decimal (mark measurement unit on HAS Form)
5. Measure the athlete's height using the stadiometer to the decimal – ensure their heels, buttocks, and top of head touch the measurement surface. Indicate the unit of measurement.
6. Calculate the BMI using the BMI wheels or phone app.
7. For athletes under age 20, calculate the BMI percentile.



Things to remember at the Bone Mineral Density(BMD) station:

1. Raise clothing so tape measure rests against bare skin, slightly above the navel.
2. Keep tape measure parallel to the floor. It should be snug, not too tight.
3. Measure waist after athlete has taken a breath and then exhaled.
4. Use the height measurement made when doing BMI.
5. Record waist and height on HAS.
6. If tape measures are given to athlete to measure their waist at home, also give the graphic instructions on how to correctly measure waist and height with help from parent or friend.
7. Thank athlete for doing a great job!
8. Don't comment on waist or height measurement.
9. The meaning of the test will be explained at Check-Out.



Things to remember at the Bone Mineral Density(BMD) station:

1. Calibrate the BMD ultrasound machines at the start of the shift. Each subsequent day run the Quality Control process.
2. Welcome the athlete and explain what will be done.
3. Athlete should remove shoes and socks before measurement.
4. Insert paper foot sheet if using Sahara.
5. Measure athlete's left and then right heels.
6. Record both results on HAS. Include **+ or – sign in front of T-score** and decimal point.
7. When machine is running the test, provide brief bone health education tips, e.g., calcium rich foods and beverages, how exercise makes bones stronger.
8. Thank athlete for doing a "great job" being tested. Don't comment on BMD T-score.



Things to remember for the Health Habits Interview station:

1. Welcome the athlete and explain you will be asking them a few questions about their health habits and behaviors and that there are no right or wrong answers.
2. Use the health habits photo guide as a tool to assist with the questions, especially for athlete's that may be non-verbal.
3. Record the responses to the questions on the HAS Form
 - a. Give the athlete time to process the question and answer – don't rush them.
 - b. Ask the question to the athlete themselves as much as possible rather than the coach or parent if present.
 - c. You can rephrase the questions, if the athlete doesn't understand the questions as is but keep the question as open-ended as possible.



Things to remember for the Blood Pressure station:

1. Validate the accuracy of the machines at the beginning of shift to ensure they are working properly.
2. Welcome the athlete to the station.
3. Use proper athlete placement (feet on the ground, arm resting on the table, leaning back in chair, no talking, etc.)
See laminated poster at BP station.
4. Make sure to use the correct cuff size for athlete (pediatric, regular, x-large).
5. Explain the process to the athlete.
6. If athlete has a repeated BP of 160/100 (either systolic or diastolic) after a bit of rest and water, let _____, at cell # _____ know. Mark urgent referral on the HAS form. **Note Clinical Director should fill in name and cell # prior to event.**
 - a. This is the sport clearance cut-off, but nothing should be indicated to the athlete as it will cause unnecessary concern and panic.





Things to remember at Education Station:

1. Review the information on the education poster before engaging with athletes.
2. Smile and welcome athlete or team to the station and let them know what topic will be shared at the station.
3. Stand when presenting information, starting with a review of the key messages on the education poster. Ask athletes questions while discussing the key messages and make it a friendly conversation rather than a speech.
4. Introduce the activity, game or demonstration to the athlete or team. These are designed to help reinforce a key message from the poster, to help athletes see how to apply the recommended health behavior.
5. Thank the athlete or team for visiting the station



Things to remember at this station:

1. Greet the athlete warmly and see how their experience at Health Promotion has been.
2. Check to see if the HAS Form is complete and the data is correctly entered, and the correct referrals are recommended (based on the reference sheets)
3. Use materials in the Check-Out binder as references for your conversation with athletes.

BMI	<ul style="list-style-type: none"> • Does the height and weight show recording to the decimal and the proper measurement unit? • Is the BMI calculated correctly? For athletes under age 20, is the BMI percentile included?
WHtR	<ul style="list-style-type: none"> • Were both waist and height recorded in the same manner, e.g., both in English or both in Metric? • Is the WHtR calculated? Waist measurement/height measurement?
BMD	<ul style="list-style-type: none"> • Does the BMD score have a + or – sign before T-score? • Does the BMD T-score have the decimal point included? • If a T-score is not recorded for one or both heels, is the reason why checked? • Based on the recorded T-scores, and looking at the lowest of the two, is correct referral checked?
BP	<ul style="list-style-type: none"> • Is BP information recorded? • Based on the recorded BP, is correct referral checked based on diastolic & systolic reading and thresholds for referral on the BP reference guide?
HH	<ul style="list-style-type: none"> • If any of the Health Habits questions aren't answered you can ask them at the Check-Out station if all athletes waiting to check out are served. • If they are missing height and weight, bone density (age 20 and older) or blood pressure, ask if they are willing to do those screenings. If yes, have an escort take them back to those stations.

1. Transfer the screening results to the **Athlete Health Report** and indicate (using the reference guides) where they are doing well and where there is area for improvement. Cross out a screening station if not offered at this event
2. Give the **Athlete Health Report**.
3. Guide the athlete select a **Choose to Change** card for the chosen goal. If they don't pick one or aren't interested in for themselves, see if they will take a card that they can use to help a friend or family member make a health behavior change.
4. Collect the HAS form, or if using tablets, close out the athlete's screen.
5. Thank the athlete for their participation and place a sticker or notation on their credential, if necessary.

DAY 1 – SCREENING HOURS: X:XX to X:XX

Station and volunteer name	Volunteer Type (Clinical Specialist, Student, or General)	Clinical specialty (e.g., physician, nurse, dietitian, public health, etc). If general, put "n/a"	Needed	Filled	% Filled
Health Promotion Check-In- general			2	0	0
Health Promotion escorts -general or clinical			2	0	0
BMI- height and weight-clinical plus general data entry			4	0	0
Waist Height Ratio-clinical plus general data entry			2	0	0
Bone Density Screening -clinical plus general data entry			4	0	0
WHtR -Waist to Height Ratio			2	0	0
Blood Pressure Screening-clinical			6	0	0
Health Habits Interview-clinical			2	0	0
Nutrition-clinical			1	0	0
Bone Health-clinical			1	0	0
Sun Safety -clinical or general			1	0	0
Physical Activity-fitness trained or clinical			1	0	0
Hydration - clinical or general			1	0	0
Tobacco -clinical or general			1	0	0
Handwashing -clinical or general			1	0	0
Check-Out and counseling-senior clinical			3	0	0

CHAPTER 7 - APPENDIX 3: Volunteer Training Guides

The following documents should be used to help train, observe, and evaluate volunteers to ensure that the proper protocol is being followed. You can access the actual training tools within Chapter 3

e. Volunteer Training Guides for

- [Body Mass Index](#)
- [Waist Height Ratio](#)
- [Bone Mineral Density](#)
- [Blood Pressure](#)

This document is a training guide for measuring blood pressure. It includes a table for recording data for two individuals, with columns for Name, Age, Height, Weight, and Blood Pressure. Below the table, there are instructions on how to measure blood pressure correctly, including steps like '1. Ask the person to rest for 5 minutes before the measurement.' and '2. The person should be seated and their feet should be flat on the floor.' It also includes a section for 'Notes' and a 'References' section.

This document is a training guide for measuring bone mineral density. It includes a table for recording data for two individuals, with columns for Name, Age, Height, Weight, and Bone Mineral Density. Below the table, there are instructions on how to measure bone mineral density correctly, including steps like '1. The person should be standing on a flat surface.' and '2. The person should be wearing a lead apron to protect themselves from radiation.' It also includes a section for 'Notes' and a 'References' section.

This document is a training guide for measuring waist height ratio. It includes a table for recording data for two individuals, with columns for Name, Age, Height, Weight, and Waist Height Ratio. Below the table, there are instructions on how to measure waist height ratio correctly, including steps like '1. The person should be standing on a flat surface.' and '2. The person should be wearing a lead apron to protect themselves from radiation.' It also includes a section for 'Notes' and a 'References' section.



Training guides and materials are available on the Health Promotion Resources website:

<https://resources.specialolympics.org/health/health-promotion>

Chapter 7- Appendix 4: Health Promotion Volunteer Training Outline

General volunteer training begins with an introduction to the Special Olympics movement and event. This outline offers suggested topics to address during orientation and training.

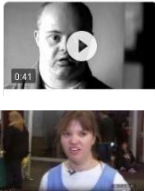
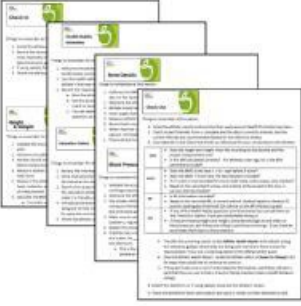
Topic	Suggested script	Visual aids, links and handouts
Pre-event volunteer training	<p>In advance of the event, share these videos with volunteers (or start day with them, if you have access to computer):</p> <ol style="list-style-type: none"> Health Promotion overview video: https://www.youtube.com/watch?v=P4VXM6o77C8&feature=youtu.be (2.04 minutes) How to communicate and work with athletes. <ul style="list-style-type: none"> I am different (41 seconds) https://www.youtube.com/watch?v=IJHQ6rn6QYk 41seconds “Talk to Me: Treating People with ID with Respect” (3.36 minutes) https://www.youtube.com/watch?v=nc9aAY6-ujQ&feature=youtu.be 	<p>Working with Our Athletes</p> 
Introduce yourself	<p>Welcome to the Health Promotion volunteer training. Volunteers are the backbone of the Special Olympics movement. We will spend time together delivering Health Promotion services to the Athletes. Let us introduce our selves. Please share your name, where you are from and what brought you here . Thanks to everyone for taking time out of your busy lives to help at this event. You won't be sorry! We have a lot to cover before the event begins.</p>	<p>Volunteer Code of Conduct</p>
Describe event logistics event	<p>Share a description of this event demographics such as numbers of athletes, coaches, family members, volunteers. Explain other planned activities.</p>	<p>Locally created handout</p>
	<p>Share information on where to park, meals and the venue schedule. Include a map of the overall campus including location of medical services. Lunch and/or dinner schedule. Set up and take down.</p>	
	<p>Share points of contact and their roles. Include cell phone numbers for key staff at the event. Provide information on who to go to with questions or concerns arise</p>	
Expectations of volunteers	<p>Stay with your scheduled station. No food or beverages at your station except water. Plans for lunch and breaks. Who to report to if you have to leave your post. Stand in front of education station table to be inviting to athletes.</p>	<p>Locally created handout</p>
Provide station specific training for the volunteers. Briefly discuss the training records for BMI, WHtR, BMD and BP. Share Things to Remember for This Station for each screening station.	<p>Screening, interview and education stations for assigned volunteers, including how to train “the next volunteer” for each station.</p> <p>Things to Remember for This Station Have laminated copies of each station instructions for training volunteers. Show the Volunteer Training record for BMI, WHtR, BMD and BP that will serve as a checklist to ensure volunteers are well trained.</p> 	<p>Things to Remember for This Station Training reference guides for each screening</p> <p>Chapters 3 and 7 Appendix</p>
Describe highlights of each education station	<ol style="list-style-type: none"> Share how to use the Volunteer Training Tool – Things to Remember for this Station. Emphasize poster content as key messages to share with athletes. Remind volunteers to stand in front of the table to be more engaging with volunteers. 	<p>Things to Remember for This Station Materials in Chapter 7 Appendix</p>

Special Olympics Health Promotion



SpecialOlympics.org/Health